

CONTENTS

- Preface3**
- Emergency Rescue Manual Introduction3
- Visual Identification Information.....4
- High Voltage Identification5

- High-voltage System7**
- High Voltage System Components7

- Emergency Rescue9**
- Safety Instructions for Emergency Rescue9
- High Voltage Isolation11
- Vehicle on Fire15
- Waterlogged Vehicle17
- Cutting18
- Jacking Or Lifting19
- Vehicle Recovery after Accident20
- Parking Operations22

CONTENTS

Vehicle Data..... 23

Vehicle Information23

Emergency Rescue Manual Introduction

Introduction

This manual is designed to be used by the emergency services. In the event of an accident or emergency the operator must have a complete understanding of high voltage systems and the health and safety protocols that are associated with them, ideally the operator should be trained and certificated in the safe handling and rescue of electric or hybrid vehicles that feature high voltage systems. In case of an emergency please give this document to the first responder.

This manual only provides specific information required to identify, locate and safely work around high voltage components in the event of an emergency. It includes important information and warnings that must be considered in emergencies. Please read this manual carefully and follow the relevant safety procedures and precautions precisely.

The illustrations used in this publication and the Owner's Handbook are for reference only.

Vehicle Manufacturer Information

For roadside assistance please contact the approved service provider – see website for details:

<https://mg.co.uk/owners/service-and-roadside-assistance/>

For first and second responders, please consult the nearest MG Authorised Repairer for assistance – see website for details: <https://mg.co.uk/dealers/>

For consumer EV enquiries, please contact the MG call centre: 020 3917 5821

PREFACE

Visual Identification Information

The mark indicating the identity of the electric car is located on the tailgate (as shown below).







High Voltage Identification



Always observe the safety instructions and requirements outlined on the warning labels associated with the high voltage system. Not all high voltage components are labeled. Wear complete insulation protection equipment at all times during rescue.



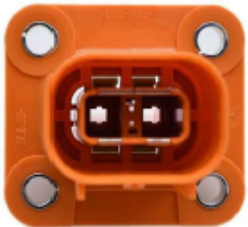





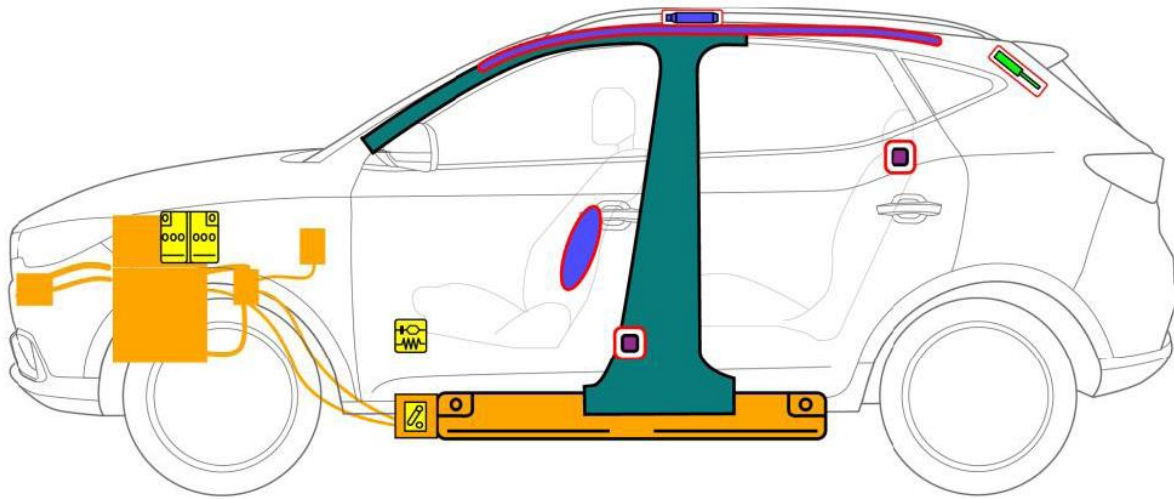
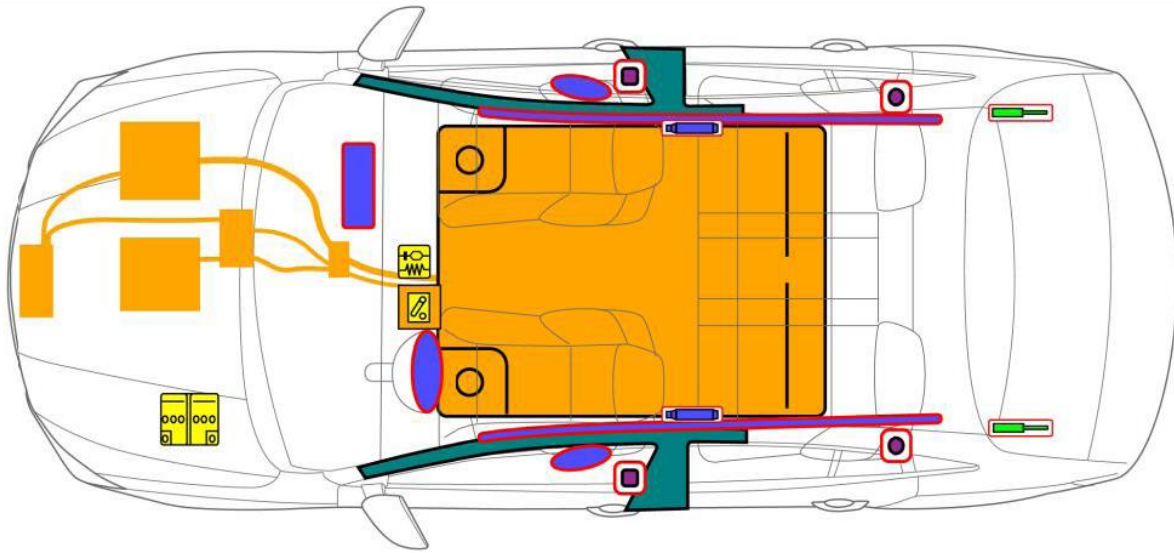











Generally high voltage systems and components that may be hazardous will carry identification, in general DO NOT touch any orange coloured components, any orange wires or anything featuring high voltage warning labels without permission or prior knowledge of high voltage systems and isolation procedures. The following are examples of high voltage warnings, components and safety labels:

PREFACE

| High Voltage Mark | High Voltage Harness | High Voltage Connector | High Voltage Label | Manual Service Disconnect |
|--|--|---|---|--|
|  |  |  |  |  |
| <p>High voltage warning sign, indicating that the corresponding components contain high voltage.</p> | <p>High voltage wiring is orange in colour, this denotes that the wiring carries high voltage.</p> | <p>High voltage connections are orange in colour, this denotes that any power passing through this connector and any component that features orange connectors is high voltage.</p> | <p>High voltage labels are located on high voltage components. Please observe and follow any safety information on the label.</p> | <p>The Manual Service Disconnect device is orange in colour. Please ensure this connector is removed and therefore isolating the high voltage system prior to working on the high voltage component or system.</p> |

Note: Depending on the market in which the vehicle is sold and the date of manufacture, the label may have been translated and is displayed in a different language.



| | | | | | | | | | |
|---|--------------------------------------|--|--------------------------------------|--|-------------------------|--|--|--|-------------------------------------|
|  | Airbag |  | Stored gas inflator |  | Seat belt pretensioner |  | SRS control unit |  | Pedestrian protection active system |
|  | Automatic rollover protection system |  | Gas strut / Preloaded spring |  | High strength zone |  | Zone requiring special attention | | |
|  | Battery low voltage |  | Ultra capacitor, low voltage |  | Fuel tank |  | Gas tank |  | Safety valve |
|  | High voltage battery pack |  | High voltage power cable / component |  | High voltage disconnect |  | Fuse box disabling high voltage system |  | Ultra capacitor, high voltage |
|  | Disconnect high voltage device | | | | | | | | |

Safety Instructions for Emergency Rescue







- During rescue, please observe the safety precautions associated with high voltage power. In all cases, priority must be given to the safety of personnel.
- Any components that feature high voltage warning labels or are orange in colour will feature high voltage electricity. Always observe any safety instructions displayed on any warning labels.
- If it is necessary to operate any high voltage components, it must be carried out by qualified personnel, supported by suitable insulated clothing, insulated protection equipment and only using insulated tools.
- If it is necessary to work with or around high voltage components, the high voltage isolation operation **MUST** be carried out in strict accordance with the "High Voltage Isolation" operation instructions outlined in this manual, any subsequent operations must be carried out observing all safety criteria.
- When lifting the vehicle using the underside, pay particular attention so as not to damage the high voltage battery pack. When using rescue tools, pay close attention to ensure that the floor is not damaged.
- Take care at all times when working with or around high voltage components, regardless of the operation, cutting, squeezing or touching high voltage components can cause serious injury or even death.

EMERGENCY RESCUE

Protective Equipment

Where it is necessary to operate or work with high voltage components it should be carried out by qualified personnel. Any operations should only be carried out using the correct personal protective equipment and insulated tools.

| Insulation protection equipment and insulation tools | Example |
|--|--|
| Insulated gloves, withstand voltages up to 1 kV |  |
| Insulated shoes, withstand voltages up to 18 kV |  |

| | |
|--|---|
| Insulated tools, withstand voltages up to 1 kV |  |
| Insulation pad, withstand voltages up to 10kV |  |

High Voltage Isolation

In cases where the vehicle power system can be shut down normally the high voltage system can be isolated by rescue personnel by disconnecting the 12V low voltage battery negative cable.

In cases of emergency, the high voltage system can be isolated by cutting the low voltage harness in the front compartment or by removing the manual service disconnect device (master safety device).

Disconnect 12V Low Voltage Battery

The vehicle power system can be shut down normally.

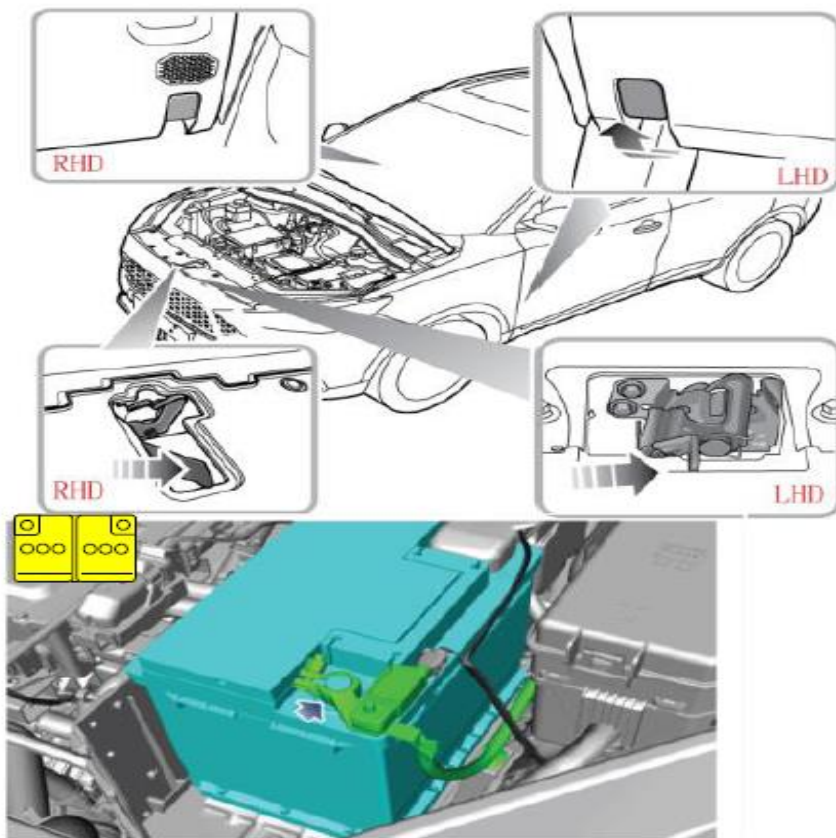

Power off and disconnect the negative cable of 12V low-voltage battery. The 12V battery position differs between vehicles.

EMERGENCY RESCUE

In cases of emergency, the high voltage system can be isolated by cutting the low voltage harness in the front compartment (Method 1) or by removing the manual service disconnect device (master safety device, Method 2).

Method 1

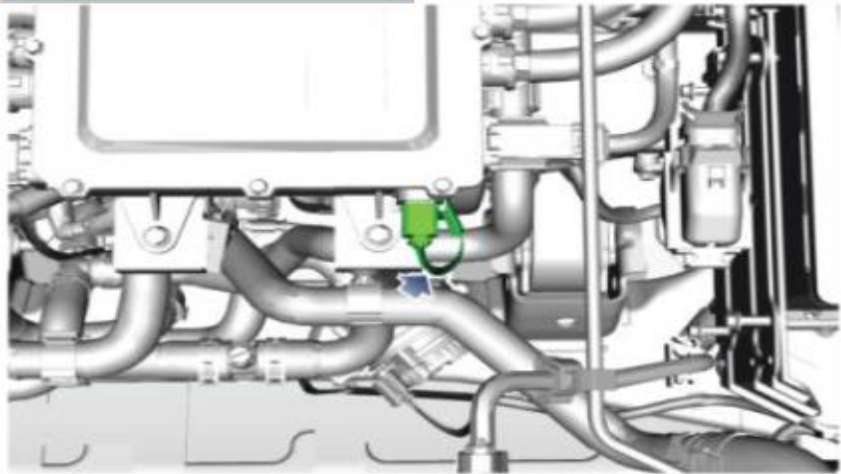

Method 1: Cut the front cabin low-voltage wiring harness.

Method 2

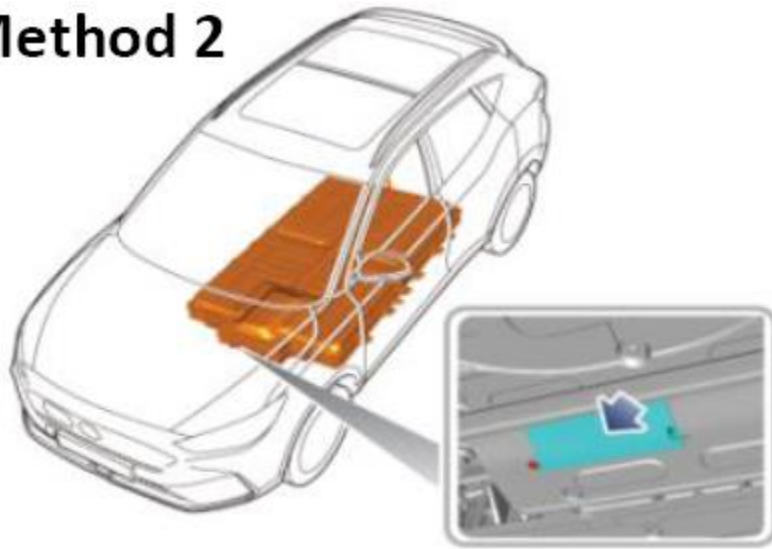

Manual Service Disconnect Removal

Where it is necessary to operate or work with high voltage components it should be carried out by qualified personnel. Any operations should only be carried out using the correct insulated personal protective equipment and insulated tools.

- 1 Lift the vehicle if safety conditions permit.
- 2 On the deflector at the front of the battery pack (under the vehicle), remove the screw on the cover plate of the manual service disconnect, release the retaining clip and remove the cover plate.
- 3 Pull out the safety locking clip on the manual service disconnect (figure A), press and hold the end of the clip (Figure B), and pull out the manual service disconnect.

EMERGENCY RESCUE

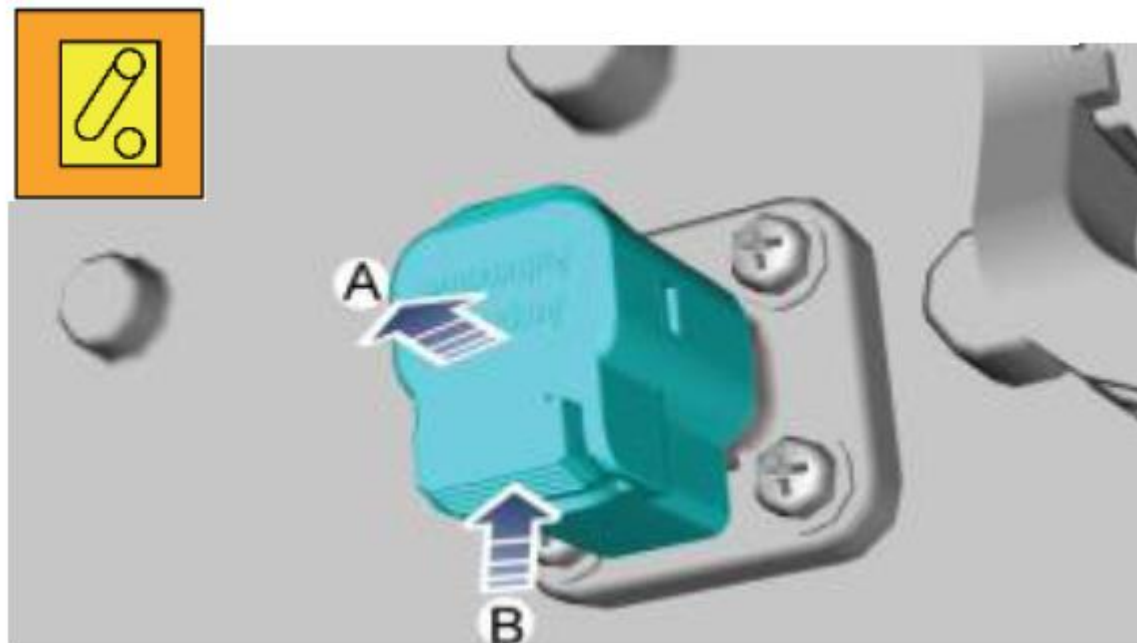

Note: After the manual service disconnect has been removed, please cover the open connector to prevent ingress of any debris or contaminants.

Note: If rescue site conditions do not allow the disconnection of the manual service disconnect, rescue personnel **MUST** disconnect the 12V battery and use the appropriate insulated personal protective equipment and tooling prior to commencing any rescue work.

IMPORTANT

Prior to disassembly of any high-voltage system components, you **MUST** confirm whether the high-voltage circuit voltage is within the safe range (the effective voltage value is no more than 30V (AC) and no more than 60V (DC)) with special equipment (voltmeter, etc.) first and then take appropriate actions.

Vehicle on Fire



In cases of rescue during vehicle fire, always wear complete personal protective equipment, including self-contained breathing apparatus (SCBA).

During cases of rescue when the vehicle is on fire, rescue personnel must use the correct insulated personal protective equipment and insulated tools.

- The driver, passengers and irrelevant personnel must be evacuated from the vehicle immediately.
- During the rescue process avoid touching the metal charged conductor of the damaged high-voltage parts to prevent possible electric shock injury.
- Do not contact any high-voltage components when extinguishing the fire, always use insulated tools for disposal. Disconnect the high-voltage output immediately when conditions permit.
- In cases of small fires where the flames do not spread to the high voltage battery pack, carbon dioxide or ABC dry powder fire extinguisher can be used.
- If the high-voltage battery pack is on fire, a large amount of continuous water can be used to spray it continuously

to reduce the temperature of the high-voltage battery pack. (If no one is trapped and the rescue conditions permit, the rescue personnel can choose to let it burn out. At the same time, ensure that the fire does not spread and avoid inhalation of toxic substances in the smoke.)

- High voltage batteries that burn or get hot release toxic gases. Emergency personnel must always use complete personal protective equipment (including SCBA) to protect themselves, and take appropriate measures to guide smoke and gas, so as to protect the surrounding people from accidents.
- There are a large number of chemicals in the battery, so there is a risk of reignition. During the process of complete extinguishing it is recommended to use a thermal imager, thermometer and other equipment to monitor the battery temperature in real time. If the temperature of the battery increases sharply, or there is excessive smoke emission, it is recommended that the water spray is directed straight onto the high voltage battery in order to cool and control the temperature.
- After the fire is completely extinguished, the accident vehicle should be transferred to a safe place for isolation

EMERGENCY RESCUE

immediately. When transferring the vehicle, it is not permitted to tow the vehicle, a suitable transporter must be used for transportation.

- If the high-voltage battery pack and high-voltage components are damaged, there may be a small amount of liquid leakage, such as lithium battery electrolyte and coolant. DO NOT touch any chemicals, clean immediately and avoid the chemicals entering the sewer or water course.
- After rescue or recovery it is important that any high voltage components or batteries are correctly handled and disposed of. Please seek advice from an MG Authorised Repairer.

Fire Extinguisher

Any fire extinguishers should be individually purchased by the owner, checked and replaced regularly as advised by the fire extinguisher manufacturer. It is recommended to use a carbon dioxide fire extinguisher or ABC dry powder fire extinguisher.



If the vehicle is on fire and the fire is small, the fire extinguisher can be used to extinguish the fire (refer to the instructions for using the extinguisher).

Note: When using the fire extinguisher, pay attention to avoid direct skin contact and possible freezing/frostbite.

Waterlogged Vehicle

The electric vehicle does not create any greater risk to life when immersed in water than a conventional vehicle. During cases of rescue when the vehicle is immersed in water, rescue personnel must use the correct insulated personal protective equipment and insulated tools.

- The driver, passengers and irrelevant personnel must be evacuated from the vehicle immediately.
- During the rescue process avoid touching the metal charged conductor of the damaged high-voltage parts to prevent possible electric shock injury.
- If there is no hissing sound or foam being emitted by the high voltage battery pack, the vehicle can be salvaged by professional organizations.
- After recovery from deep or flood water the vehicle high voltage system must be isolated and placed in an open place for isolation.
- When recovering vehicles, it is not allowed to tow them directly. Suitable recovery vehicles must be used for transportation.
- After rescue or recovery it is important that any high voltage components or batteries are correctly handled and disposed of. Please seek advice from an MG Authorised Repairer.

EMERGENCY RESCUE

Cutting



No matter what disable procedure is used, care should always be taken with all high-voltage components to avoid possible power-on risks, cutting, squeezing or touching high voltage components may cause serious injury or death.

Please use an appropriate tool to cut the vehicle, such as a hydraulic cutter, always wear appropriate personal protective equipment, otherwise serious personal injury or death may occur.

- High voltage, gas canisters, supplementary restraint system (SRS) and other components are defined as non-cutting areas (red circle area in the figure). Do not cut or squeeze these areas, this may cause serious injury or death. High voltage components can be cut only after the high voltage system is isolated, except for the high-voltage battery pack.
- In order to protect the passengers in a collision, some areas are reinforced with ultra high strength steel, these areas can be cut or squeezed with appropriate tools (cyan area in the figure).

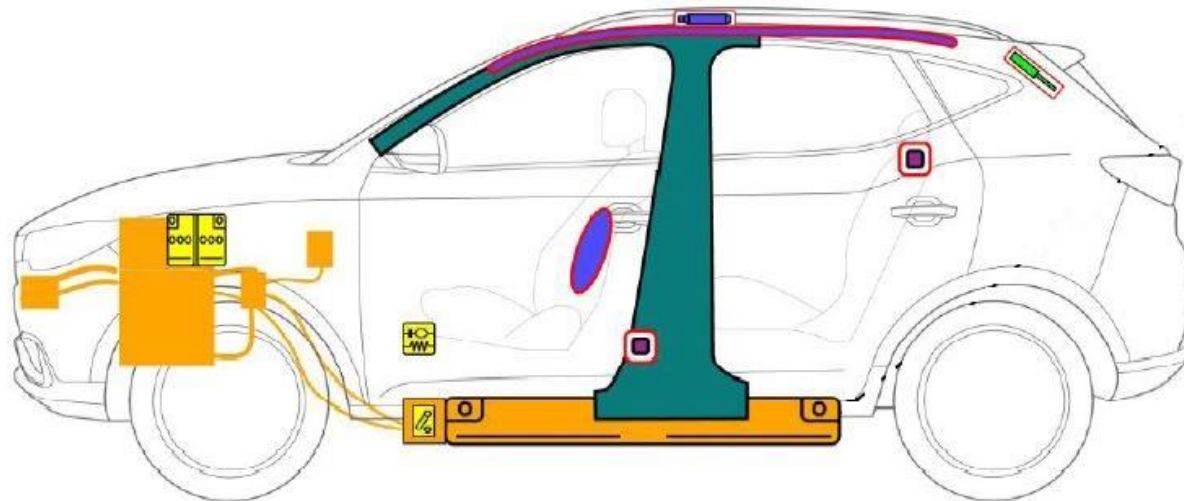

- Areas suitable for cutting
- Cutting or squeezing MUST be avoided



Jacking Or Lifting

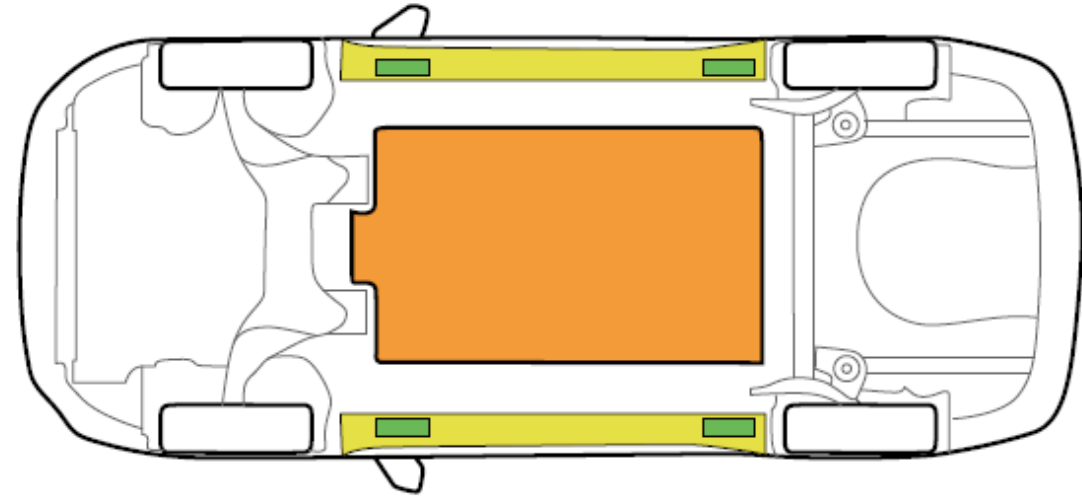

When jacking or lifting the vehicle take extra care to not damage the high-voltage battery pack. When using rescue tools, pay special attention to ensure that the floor is not damaged.

The high voltage battery pack is located on the bottom of the vehicle. When jacking or stabilizing the vehicle, only use the designated lifting area (shown in green) and make sure that there is no contact with the high-voltage battery pack (shown in orange area) or other high-voltage components.



-  Lifting Position
-  Battery Location

EMERGENCY RESCUE

Vehicle Recovery after Accident

After an accident, vehicle recovery advice is as follows:

Transporter or Trailer

To transport the vehicle on a transporter or trailer, fit wheel chocks (1) as shown, then position the anti slip rubber blocks (2) around the circumference of the wheel. Meanwhile, fit the lashing straps (3) around the wheels and secure them on the trailer. Fasten the straps to secure the vehicle.

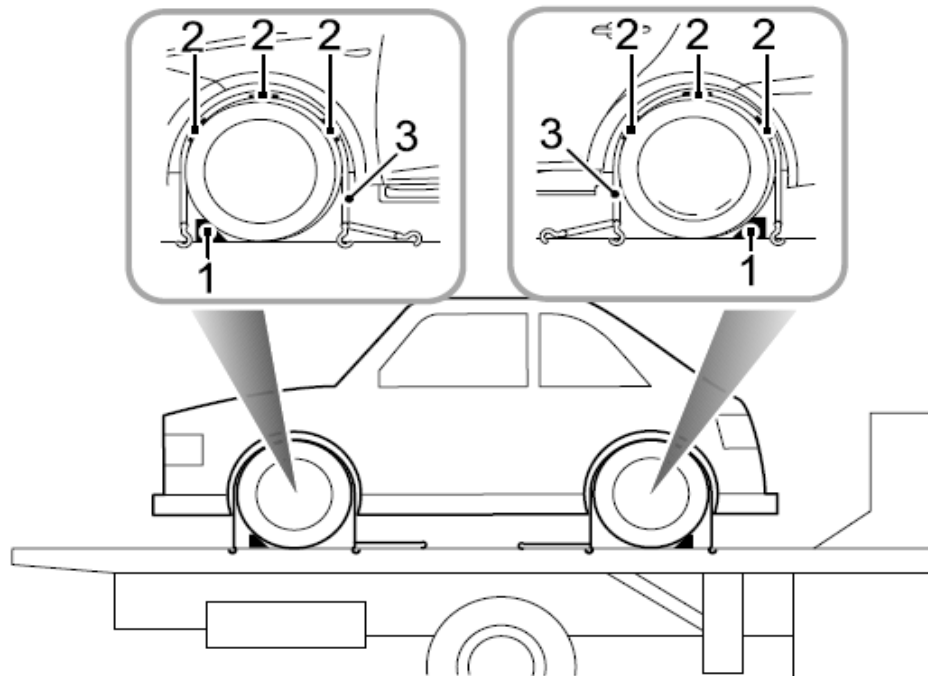

In cases where the vehicle breaks down or encounters an accident, you can use the towing hook to tow your vehicle, such as towing your vehicle onto the transporter. But they are not designed for towing other vehicles. The vehicle can be towed by using a soft rope, but a hard rod is recommended. Please consult the Owner's Handbook for detailed instructions.

Suspended towing is the best method for a vehicle that needs to be towed. The driven wheels **MUST** be suspended above the ground, this is to avoid any damage to the drive components and possible inadvertent powering of the vehicle. Ensure the EPB is released, the hazard lamps are ON and no passengers are in the vehicle.

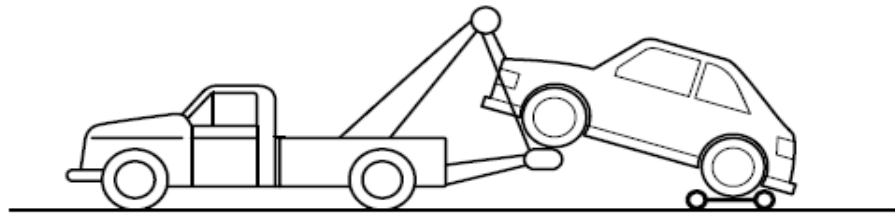
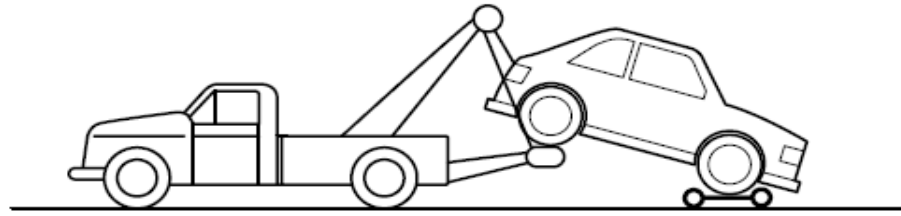
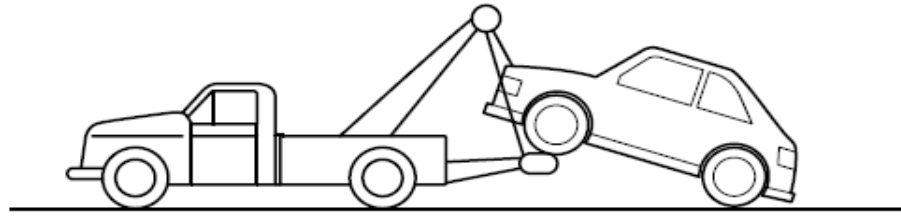

Precautions on Vehicle Towing

IMPORTANT

- The vehicle can be towed from the site only when there is no safety risk. If the battery pack is deformed, leaks, smokes, etc., the safety risk should be solved first.
- When using a transporter to ship the vehicle always ensure the parking brake is applied.
- Before towing the vehicle, release the parking brake, switch on the hazard warning lamps, close all doors and lock the vehicle.
- When towing, **DO NOT** suddenly accelerate or brake suddenly, this can cause accidents.
- Personnel are prohibited from staying in the vehicle when towing and shipping the vehicle.
- When pushing or towing the vehicle from a dangerous situation or onto the transporter, the speed must remain below 5km/h and be completed within 3 minutes.

EMERGENCY RESCUE

Parking Operations

After the vehicle has been pulled over, the vehicle power system can be switched off by following the instructions below:

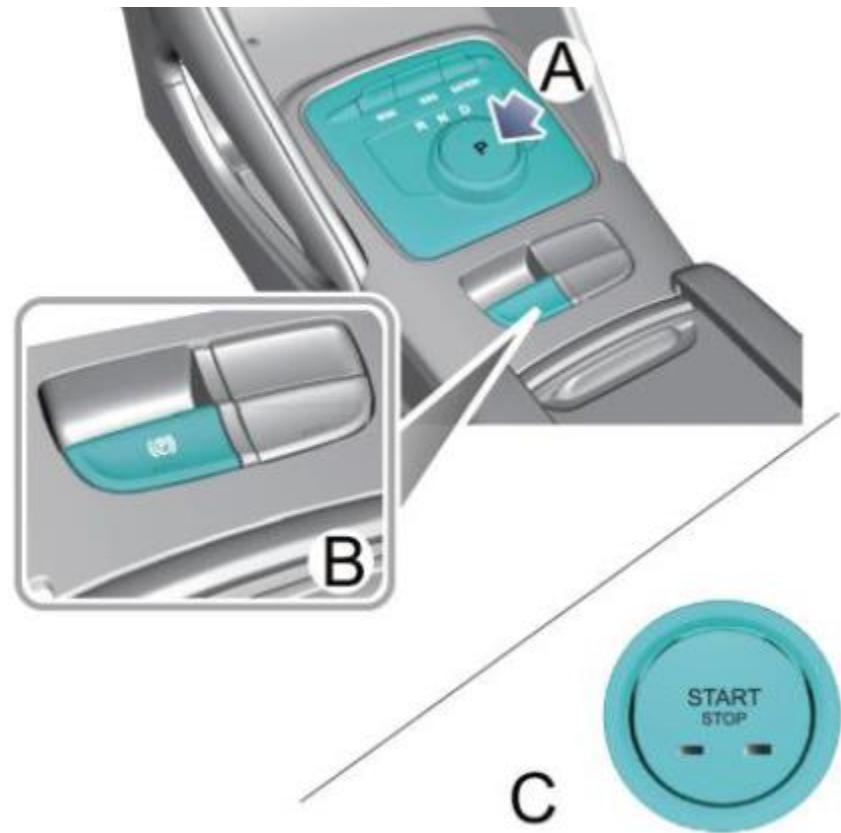

- 1 After bringing the car to a stop, ALWAYS apply the parking brake.
- 2 Ensure P is selected (A).
- 3 Make sure the EPB is applied (B).

Note: Selecting P using the shift control knob will automatically apply the EPB, if the EPB fails to automatically apply, pull the EPB switch (located in the centre console) upwards until the indicator lamp in the switch illuminates to manually apply the EPB, the indicator (P) in the instrument pack will be illuminated at the same time.

- 4 Press the START/STOP Switch (C) to shut down the power system. (After switching off the power system, the LED's in the START/STOP switch will both be OFF.)

Technical Data Dimensions

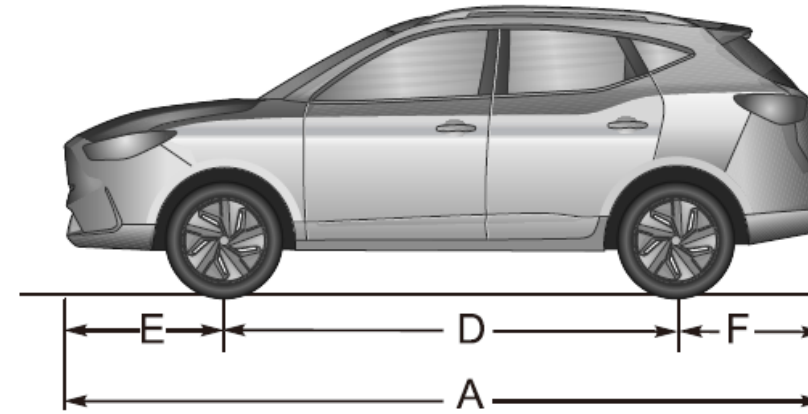
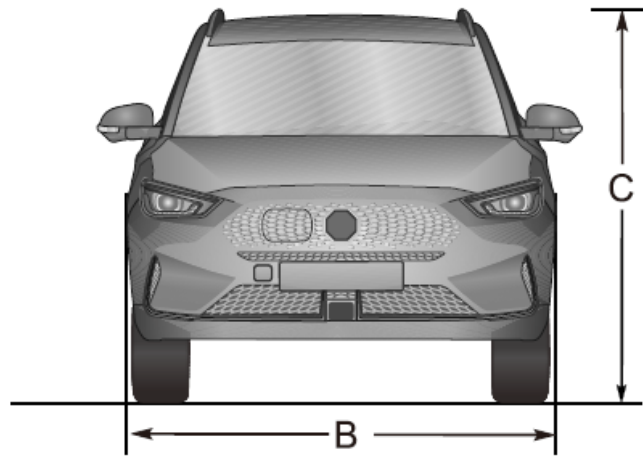

| Item, Units | Parameters |
|--------------------------------|--------------------------------------|
| Overall length A, mm | 4323 |
| Overall width B, mm | 1809 |
| Overall height C (unladen), mm | 1625(body height) 1649(with rack) |
| Wheelbase D , mm | 2585 |
| Front Overhang E , mm | 901 |

| Item, Units | Parameters |
|------------------------------|------------|
| Rear Overhang F , mm | 837 |
| Front Wheel Track , mm | 1526 |
| Rear Wheel Track , mm | 1539 |
| Minimum Turning Diameter , m | 11.2 |

Note: Vehicle length not including the license plate.

TECHNICAL DATA

Weights

| Item, Units | Parameters | | |
|-----------------------------------|------------|------------|-----------------|
| | SE(51) | Trophy(51) | SE & Trophy(72) |
| Person in cab, person | 5 | | |
| Unladen vehicle weight (kerb), kg | 1570 | 1610 | 1620 |
| Gross vehicle weight, kg | 2060 | 2060 | 2070 |
| Unladen front axle weight, kg | 891 | 908 | 914 |
| Unladen rear axle weight, kg | 679 | 702 | 706 |
| Gross front axle weight, kg | 1014 | 1014 | 1020 |
| Gross rear axle weight, kg | 1046 | 1046 | 1050 |

TECHNICAL DATA

Parameters of Traction Motor

| Item, Units | Parameter Values | |
|--|--|---------------------|
| | Battery Pack Type 1 | Battery Pack Type 2 |
| Traction motor type | Three-phase permanent magnet synchronous motor | |
| Continuous Power/Maximum Net Power, kW | 75/130 | 73/115 |
| Peak Torque, Nm | 280 | 280 |
| Rated Speed/Maximum Speed, rpm | 9000/15000 | 8000/15000 |
| Winding Type | △ | |
| Waterproof Grade | IP67 | |