

Preface	1
Introduction	1
The Owner's Handbook	1
Status at Time of Printing	1
Warranty.....	1
Symbols Used	2
In an Emergency.....	3
Vehicle Identification Information	4
Vehicle Identification	4
Vehicle Identification Label	5
I Instruments and Controls	7
Instruments and Controls	8
Instrument Pack	10
Instrument Pack - Colour Display A *	10
Instrument Pack - Colour Display B *	11
Information Centre	13
Information Centre - Colour Display A *	13
Information Centre - Colour Display B *	21

CONTENTS

Warning Lights and Indicators	29
Lights and Switches	37
Master Lighting Switch.....	37
Headlamp Levelling Manual Adjustment.....	39
Fog Lamp Switch.....	40
Direction Indicator/Main Beam Switch.....	41
Hazard Warning Lamp.....	42
Wipers and Washers	43
Windscreen Wiper Operation.....	43
Programmed Wash/Wipe.....	44
Rear Window Wiper Operation.....	45
Steering System	47
Adjustment of Steering Column.....	47
Electric Power Steering.....	48
Horn	49
Mirrors	50
Door Mirrors.....	50
Interior Rearview Mirror.....	52
Sunvisor	53

Windows	54
Power Operated Window Switch	54
Window Operation.....	54
Sunroof *	56
Instructions	56
Sunroof Operation	57
Interior Lights	61
Power Socket	62
Storage Devices	64
Instructions	64
Glove Box.....	64
Card Box.....	65
Centre Console Armrest Box	65
Loadspace	66
Cup Holder	67
Centre Console Cup Holder (EPB).....	67
Centre Console Cup Holder (IPB).....	67
Roof Luggage Rack *	68
Maximum Authorised Load for the Roof.....	68

CONTENTS

Periodical Check	68
2 Air Conditioning and Audio Systems	69
Ventilation	70
A/C Particle/Pollen Filter	71
Vents	71
Electronic Temperature Control	73
Infotainment Screen Control Interface	73
Control Panel	76
A/C Display	78
Entertainment Player.....	79
Important Safety Information	79
Cautions for Using Screen	80
Additional Notes.....	80
Basic Operations	81
Bluetooth Phone.....	87
Entertainment.....	94
Vehicle-Mobile Phone Interconnection *	102
A/C	103
Vehicle Settings.....	103

Settings	104
3 Seats & Restraints.....	107
Seats.....	108
Overview	108
Head Restraints.....	108
Front Seats	109
Rear Seats.....	111
Front Seat Heating *	111
Seat Belts	113
Protection Provided by Seat Belts	114
Wearing Seat Belts.....	115
Children and Seat Belts	119
Seat Belt Pre-tensioners.....	120
Seat Belt Checks, Maintenance and Replacement.....	121
Airbag Supplementary Restraint System	124
Overview	124
Airbag Deployment	125
Conditions in Which Airbags Will Not Deploy	128
Disabling the Passenger Airbag.....	129

CONTENTS

Service and Replacement of Airbags.....	131
Disposal of Airbags.....	132
Child Restraints	133
Important Safety Instructions about Using Child Restraints	133
Child Restraints Groups.....	136
Approved Child Restraint Positions	139
4 Starting & Driving.....	145
Keys	146
Overview	146
Replacing the Battery.....	147
Child Proof Locks	151
Alarm System	152
Engine Immobilisation	152
Anti-theft System	153
Tailgate.....	157
Starting and Stopping Engine	159
Ignition Switch (Key Start) *	159
START/STOP Switch (Keyless Start)*	160

Starting the Engine (Key Start) *	162
Starting the Engine (Keyless Start) *	163
Precautions for Starting the Engine	165
Stopping the Engine	166
Economical and Environmental Driving	167
Running-in	167
Environment Protection	167
Economic Driving and Maintenance	167
Driving in Special Environment	169
Catalytic Converter and Particulate Filter	170
Fuel System	172
Fuel Requirements	172
Fuel Filler	173
Refueling	173
Automatic Transmission *	174
Instructions	174
Gear Shift	174
Driving on the Hill	177
Control Mode	178

CONTENTS

Manual Transmission *	181
5-speed Manual Transmission *	181
6-speed Manual Transmission *	182
Brake System	184
Foot Brake	184
Electronic Brake Force Distribution (EBD)	185
Electronic Brake Assistance (EBA)	185
Hill Hold Control (HHC)	185
Hill Descent Control (HDC)	187
Anti-lock Brake System (ABS)	189
Auto Hold *	191
Emergency Braking Hazard Warning Lights Control (HAZ)	193
Active Rollover Protection (ARP)	193
Parking Brake *	194
Electronic Parking Brake (EPB) *	195
Automated Stop/Start — Intelligent Fuel Saving System	197
Automatic Shutdown of Engine	198
Engine Auto Stop Conditions	198
Stop/Start Prohibited	198

Automatic Engine Start	199
Start Inhibition.....	199
Stall Assist.....	200
Battery.....	200
Automated Stop/Start Intelligent Fuel Saving System Failure	201
Starter Inoperative, Serious Battery Capacity Loss	201
Stability Control System (SCS) and Traction Control System (TCS).....	202
Cruise Control System	204
Active Speed Limit (ASL) System.....	207
Activate.....	207
Kick Down	208
Suspending ASL	208
Resuming ASL.....	208
Overshoot of Target Speed and Warning.....	209
Parking Aid System *	210
Ultrasonic Sensor Parking Aid *	210
360 Panoramic Imaging System *	212
Rear Driver Assistance System *	214
System Overview.....	214

CONTENTS

Switching the System Functions On/Off	216
System Functions	216
Tyre Pressure Monitoring System (TPMS).....	220
Load Carrying	222
Load Space	222
Internal Loading	223
General Towing Safety	223
5 Emergency Information	225
Hazard Warning Devices.....	226
Hazard Warning Lights	226
Warning Triangle.....	226
Emergency Starting	228
Using Booster Cables	228
Starting the Car	228
Vehicle Recovery.....	230
Towing for Recovery.....	230
Transporter or Trailer with Rope.....	233
Tyre Repair and Wheel Replacement	235

Tool Identification	235
Tyre Repair	235
Changing a Wheel *	238
Fuse Replacement	242
Fuse	242
Fuse Box	242
Passenger Compartment Fuse Box	243
Front Compartment Fuse Box	246
Bulb Replacement	250
Bulb Specification	250
Bulb Replacement	251
6 Maintenance	259
Maintenance	260
Routine Maintenance	260
Bonnet	264
Opening the Bonnet	264
Closing the Bonnet	264
Bonnet Open Warning	264

CONTENTS

Engine Compartment	266
1.5L Engine Compartment.....	266
1.0L Turbocharged Engine Compartment.....	267
Engine	268
Engine Oil	268
Engine Oil Level Check and Top Up.....	268
Engine Oil Specification	269
Cooling System	270
Coolant Check and Top Up	270
Coolant Specification	270
Brake	272
Brake Pads	272
Brake Fluid Check and Top Up.....	272
Brake Fluid Specification	273
Battery	274
Battery Maintenance	274
Battery Replacement.....	274
Washers	276
Windscreen Washer Check and Top Up	276

Washer Nozzles.....	277
Washer Fluid Specification	277
Wipers	278
Wiper Blades	278
Replacing Front Wiper Blades	279
Replacing Rear Wiper Blades	280
Tyres.....	281
Overview	281
New Tyres	281
Directional Tyres.....	281
Tyre Life	281
Tyre Pressure.....	282
Driving Style.....	282
Wheel Balance.....	282
Wheel Alignment.....	282
Caring for Your Tyres	282
Tyre Pressure.....	283
Valves	283
Punctured Tyres	283

CONTENTS

Tyre Wear Indicators	283
Replacement Tyres	284
Wheel Fitment Rotation	284
Snow Chains	285
Cleaning and Vehicle Care.....	287
External Car	287
Cleaning the Interior.....	290
7 Technical Data	293
Technical Data Dimensions	294
Weights.....	296
Towing Weights	296
Towing Bar Dimensions.....	297
Major Parameters of Engine	299
Recommended Fluids and Capacities	301
Wheel Alignment (Unladen Condition)	302
Wheels and Tyres	302
Tyre Pressure (Cold)	302

8 Appendix	303
Removable Tow Bar	304
Tow Bar Operating Instructions.....	304

Introduction

The Owner's Handbook

This handbook describes all of the vehicles and standard equipment specification within the model range. Some of the information therefore, may not apply to your particular car.

Always remember that if you have any queries concerning the operation or specification of your car, your MG Authorised Repairer will be glad to advise you.

The illustrations in the Owner's Handbook are for reference only.

The information presented in this manual may vary slightly depending on vehicle configuration, software version and sales area.

Status at Time of Printing

MG operates a policy of constant product improvement and therefore reserves the right to change specifications without notice at any time. Whilst every effort is made to ensure complete accuracy of the information in this publication, no liabilities for inaccuracies or the

consequences thereof, including loss or damage to property, or injury to persons, can be accepted by the manufacturer or MG Authorised Repairer who supplied the publication, except in respect of personal injury caused by the negligence of the manufacturer or MG Authorised Repairer.

Warranty

Please consult mg.co.uk for the vehicle warranty terms and conditions, warranty statement and exemptions.

PREFACE

Symbols Used

The following symbols used within the handbook call your attention to specific types of information.

Warning



This warning symbol identifies procedures that must be followed precisely, or information that must be considered with great care, in order to reduce the risk of personal injury or serious damage to the car.

Important

IMPORTANT

The statements stated here must be followed strictly, otherwise your car could be damaged.

Note

Note: *This describes helpful information.*



This symbol indicates parts described must be disposed of by authorised persons or bodies to protect the environment.

Asterisk

An asterisk (*) appearing within the text, identifies features or items of equipment that are either optional, or are only fitted to some vehicles in the model range.

Illustration Information



Identifies components being explained.



Identifies movement of components being explained.

In an Emergency

IMPORTANT

Remember the breakdown safety code

If a breakdown occurs while travelling:

- Wherever possible, consistent with road safety and traffic conditions, the car should be moved off the main thoroughfare, preferably into a lay-by. If a breakdown occurs on a motorway, pull well over to the inside of the hard shoulder.
- Switch on hazard lights.
- If available, position a warning triangle or a flashing amber light 150 to 500 ft behind your vehicle to warn approaching traffic. Note it is a legal requirement of some countries that a warning triangle is carried in the vehicle, if in doubt consult the local highways agency for further information.
- Consider evacuating passengers through nearside doors onto the verge as a precaution in case your vehicle is accidentally struck by other traffic.

PREFACE

Vehicle Identification Information

Vehicle Identification

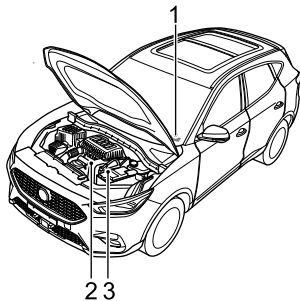

- 1 Vehicle Identification Number (VIN)
- 2 Engine Number
- 3 Transmission Number

Always quote the Vehicle Identification Number (VIN) when communicating with your MG Authorised Repairer.

If the engine or transmission is involved, it may be required to provide the identification numbers of these assemblies.

Vehicle Identification Location

Vehicle Identification Number (VIN)

- Stamped on a plate visible through the bottom left hand corner of the windscreen;
- On the identification plate;
- On the floor under the front right hand seat;
- On the inner side of the tailgate visible by opening the tailgate.

Note: *The DLC is located in the driver footwell at the base of the fascia panel on the RH side. The VIN information can be extracted from the vehicle using the approved diagnostic equipment.*

Engine Number Location

Stamped on the front right of the cylinder block (View from the front of the engine).

Transmission Number Location

On the surface of the transmission housing in the engine compartment. The transmission numbers of certain models are only visible by raising the vehicle, please contact a local Authorised Repairer.

Vehicle Identification Label

The vehicle identification label contains the following information:

- Type Approval Number;
- Engine Type;
- Vehicle Identification Number (VIN);
- Gross Vehicle Weight;
- Gross Train Weight *;
- Max Front Axle Weight *;
- Max Rear Axle Weight *;
- Paint Code
- Trim Code

PREFACE

Location of Vehicle Identification Label

The identification label is located at the lower side of right pillar B

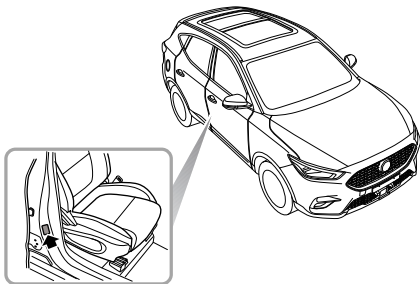

Instruments and Controls

- | | | | |
|----|--------------------------------------|----|----------------------------|
| 8 | <i>Instruments and Controls</i> | 62 | <i>Power Socket</i> |
| 10 | <i>Instrument Pack</i> | 64 | <i>Storage Devices</i> |
| 13 | <i>Information Centre</i> | 67 | <i>Cup Holder</i> |
| 29 | <i>Warning Lights and Indicators</i> | 68 | <i>Roof Luggage Rack *</i> |
| 37 | <i>Lights and Switches</i> | | |
| 43 | <i>Wipers and Washers</i> | | |
| 47 | <i>Steering System</i> | | |
| 49 | <i>Horn</i> | | |
| 50 | <i>Mirrors</i> | | |
| 53 | <i>Sunvisor</i> | | |
| 54 | <i>Windows</i> | | |
| 56 | <i>Sunroof *</i> | | |
| 61 | <i>Interior Lights</i> | | |

INSTRUMENTS AND CONTROLS

Instruments and Controls

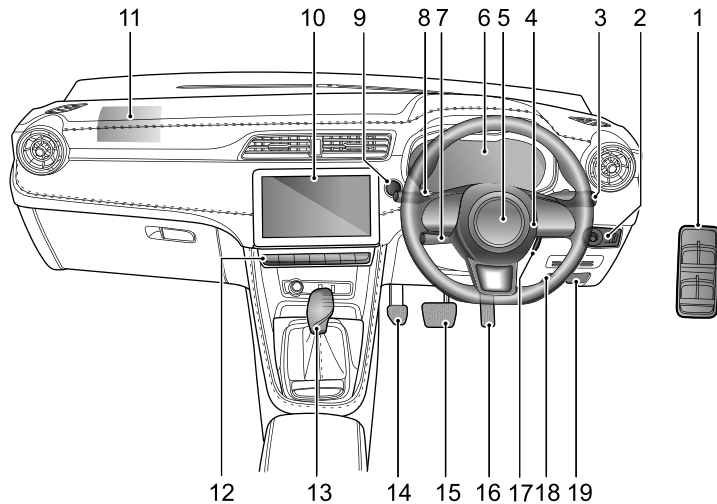

INSTRUMENTS AND CONTROLS

- 1 Power Window Switch
- 2 Exterior Rearview Mirror and Headlamp Leveling Switch
- 3 Wiper Stalk Switch
- 4 Horn Button
- 5 Driver Airbag
- 6 Instrument Pack
- 7 Cruise Control/ASL Stalk Switch
- 8 Indicator/Main Beam Stalk Switch
- 9 START/STOP Switch (Keyless Start) *
- 10 Infotainment System
- 11 Front Passenger Airbag
- 12 Infotainment/Air Conditioning Control Switch
- 13 Gear Shift Lever
- 14 Clutch Pedal *
- 15 Brake Pedal
- 16 Accelerator Pedal
- 17 START/STOP Switch (Key Start) *
- 18 Bonnet Release Handle
- 19 Fuel Filler Flap Release Handle

INSTRUMENTS AND CONTROLS

Instrument Pack

Instrument Pack - Colour Display A *



Speedometer (1)

Indicates the vehicle speed in mph and km/h.

Tachometer (2)

Indicates the engine speed, $\times 1000$ rpm.

IMPORTANT

To protect the engine from damage, never allow the pointer to remain in the red sector of the gauge for prolonged periods.

Engine Coolant Temperature Gauge (3)

Indicates the engine coolant temperature.

Fuel Gauge (4)

Indicates the quantity of fuel in the tank.

The low fuel warning lamp will illuminate yellow or flash when the fuel remaining in the fuel tank is low.

IMPORTANT

If the low fuel warning lamp illuminates, please refuel as early as possible.



Indicates that the fuel filler is located on the right side of the vehicle.

Instrument Pack - Colour Display B *

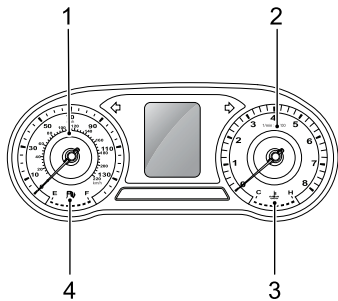

Speedometer (1)

Indicates the vehicle speed in mph and km/h.

Tachometer (2)

Indicates the engine speed, $\times 1000$ rpm.

IMPORTANT

To protect the engine from damage, never allow the pointer to remain in the red sector of the gauge for prolonged periods.

Engine Coolant Temperature Gauge (3)

Indicates the engine coolant temperature.

Fuel Gauge (4)

Indicates the quantity of fuel in the tank.

The low fuel warning lamp will illuminate yellow or flash when the fuel remaining in the fuel tank is low.

IMPORTANT

If the low fuel warning lamp illuminates, please refuel as early as possible.



Indicates that the fuel filler is located on the right side of the vehicle.

INSTRUMENTS AND CONTROLS

Note: Depending on the vehicle options, software version and market area, the information displayed may vary slightly.

*Note: The units can be changed using the entertainment system. Please use the operation steps:
Setup – Display - Units*

Information Centre

Information Centre - Colour Display A *

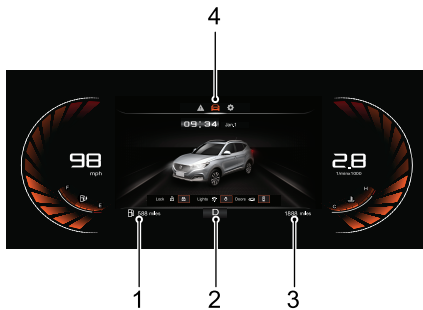

The information centre provides the followings:

- 1 Range To Empty
- 2 Gear Display and Gear Shift Indication
- 3 Total Mileage

4 General Information

Range To Empty

Displays the estimated mileage that the vehicle can travel before the fuel gauge reads empty.

Gear Display and Gear Shift Indication

Displays the current gear position of the transmission (P *, R *, N *, D *, S *, 1, 2, 3, 4, 5, 6 *). When an arrow is displayed to the right of the gear position indicator, it advises the driver to shift gear when the conditions permit. If "EP" is displayed, it indicates that a fault has been detected with the transmission. Please seek an MG Authorised Repairer as soon as possible. Refer to "Starting & Driving" section.

Total Mileage

Displays the total driving mileage of the vehicle.

General Information

The general information function can be selected as follows:

INSTRUMENTS AND CONTROLS

- Press the UP/DOWN/LEFT/RIGHT button on the right hand multifunction steering wheel switch to shift the display items.
- Press the UP/DOWN button on the right hand multifunction steering wheel switch to make adjustment.
- Press the OK button on the right hand multifunction steering wheel switch to confirm or long press OK button to reset.



General information provides the following:

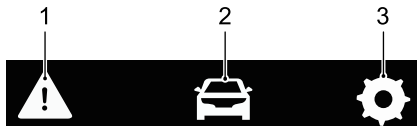

- 1 Warning Information
- 2 Trip Computer
- 3 Setting

Warning Information

Displays the warning information or important notes that are currently relevant to the vehicle.

Trip Computer

Trip computer functions contain the following:

- **Default Page:** displays the current status of the locks, lights and doors.
- **Current Journey:** displays the range, duration, average speed and average fuel consumption since startup.

These values will be reset after a period of power off. It can also be reset by long pressing the OK button on the right hand multifunction steering wheel switch.

- **Accumulated Total:** displays the range, duration, average speed and average fuel consumption since the last reset. It can be reset by long pressing the OK button on the right hand multifunction steering wheel switch.
- **Tyre Pressures:** displays the current tyre pressure data for each wheel.
- **Battery Voltage:** displays the 12V Battery Voltage.

Setting

Brightness

Displays the current level and allows adjustment of the backlight brightness.

Speed Warning

Allows the setting of the over-speed alarm threshold.

Next Service

Displays and facilitates the reset of the current vehicle maintenance information.

Warning Message

Warning messages and prompts are displayed in the information centre in the instrument pack. Any communications are displayed in 'pop up' messages, these can be divided into the following categories:

- Operating Instruction
- System State Instruction
- System Malfunction Alert

Please follow the instructions displayed in the 'pop up' message or in the case of a warning message, please refer to the relevant section of the owners manual to follow the correct instructions.

The following are a selection of warning messages that may appear in the information centre.

INSTRUMENTS AND CONTROLS

Warning Message	Procedure
Cruise Control Fault	Indicates that the cruise control system has detected a fault. Please consult an MG Authorised Repairer as soon as possible.
Active Speed Limiter Fault	Indicates that the active speed limit system has detected a fault. Contact an MG Authorised Repairer as soon as possible.
Engine Coolant Temperature High	High engine coolant temperature could result in severe damage. As soon as conditions permit, safely stop the vehicle and switch off the engine and contact an MG Authorised Repairer immediately.
Engine Coolant Temperature Sensor Fault	Indicates that the engine coolant temperature sensor has failed. As soon as conditions permit, safely stop the vehicle and switch off the engine and contact an MG Authorised Repairer immediately.

Warning Message	Procedure
Low Oil Pressure	Indicates that the oil pressure is too low, which may result in severe engine damage. As soon as safety permits, stop the car, switch off the engine and check the engine oil level. Contact an MG Authorised Repairer as soon as possible.
Engine Fault	Indicates that a failure has occurred that will effect engine performance and emissions. Contact an MG Authorised Repairer as soon as possible.
Check Engine	Indicates that a failure has occurred that may severely damage the engine. As soon as conditions permit, safely stop the vehicle , switch off the engine and contact an MG Authorised Repairer immediately.

INSTRUMENTS AND CONTROLS

1

Warning Message	Procedure
Stop Start System Fault	Indicates that the Stop/Start intelligent fuel saving system has detected a fault. Please consult an MG Authorised Repairer as soon as possible.
Clutch Switch Fault	Indicates that the clutch switch has detected a fault. Please consult an MG Authorised Repairer as soon as possible.
Gasoline Particular Filter Full	Indicates that the gasoline particular filter is full. Please consult an MG Authorised Repairer as soon as possible.
Ignition System Fault	Indicates that the ignition system has detected a fault. Please consult an MG Authorised Repairer immediately.

Warning Message	Procedure
Start Stop Button Fault	Indicates that the Start Stop button has detected a fault. Please consult an MG Authorised Repairer immediately.
Passive Entry Fault	Indicates that the passive keyless entry (PKE) function has detected a fault. Please consult an MG Authorised Repairer as soon as possible.
ABS Fault	Indicates that the anti-lock brake system (ABS) has failed and the ABS function is about to be disabled. Please consult an MG Authorised Repairer immediately.

INSTRUMENTS AND CONTROLS

Warning Message	Procedure
Brake Fault	Indicates that the brake fluid could be low or a fault has been detected in the Electronic Brake-force Distribution (EBD) system. As soon as safety permits, stop the car, switch off the engine and check the brake fluid level. Contact an MG Authorised Repairer as soon as possible.
Stability Control Fault	Indicates that the stability control system has detected a fault. Please consult an MG Authorised Repairer immediately.
Traction Control Fault	Indicates that the traction control system has detected a fault. Please consult an MG Authorised Repairer immediately.

Warning Message	Procedure
EPB System Fault	Indicates that the electronic parking brake system (EPB) has detected a fault. Please consult an MG Authorised Repairer as soon as possible.
Park Brake Force Not Enough	Indicates that there is an issue with the electronic parking brake, it may not be able to provide adequate clamping force. Contact an MG Authorised Repairer as soon as possible.
Autohold Fault	Indicates that the Autohold System has detected a fault. Please consult an MG Authorised Repairer as soon as possible.
Hill Descent Control Fault	Indicates that the hill descent control system has detected a fault. Please consult an MG Authorised Repairer as soon as possible.

INSTRUMENTS AND CONTROLS

1

Warning Message	Procedure
EPS Performance Reduced	Indicates that the electric power steering system has a general failure and that the steering performance has been reduced. As soon as conditions permit, safely stop the vehicle and switch off the engine. After a short while, start the engine, drive the vehicle a short distance and monitor the operation of the steering, if the message is still displayed or the steering assistance reduced please contact an MG Authorised Repairer immediately.
EPS Assistance Failure	Indicates that the electric power steering system has failed. Please consult an MG Authorised Repairer immediately.

Warning Message	Procedure
Steering Angle Fault	Indicates that the steering angle sensor has failed. Please consult an MG Authorised Repairer as soon as possible.
Steering Angle Uncalibrated	Indicates that the steering angle sensor is not calibrated. Please consult an MG Authorised Repairer as soon as possible.
ESCL Fault	Indicates that a fault has been detected with the Electronic Steering Column Lock (ESCL). As soon as conditions permit, safely stop the vehicle and switch off the engine. Contact an MG Authorised Repairer as soon as possible.
Fuel Sensor Fault	Indicates that fuel sensor has detected a fault. Please consult an MG Authorised Repairer as soon as possible.

INSTRUMENTS AND CONTROLS

Warning Message	Procedure
Airbag Fault	Indicates that the Airbag system has detected a fault. As soon as conditions permit, safely stop the vehicle and switch off the engine and contact an MG Authorised Repairer immediately.
Front Left/Front Right/Rear Left/Rear Right Tyre Sensor Battery Low	Indicates that the Tyre Pressure Monitoring system has detected that a tyre pressure sensor has a low battery. Please consult an MG Authorised Repairer as soon as possible.
TPMS Fault	Indicates that the tyre pressure monitoring system has detected a fault. Please consult an MG Authorised Repairer as soon as possible.

Warning Message	Procedure
12V Battery Charging System Fault	Indicates that the 12V battery charging system has failed. Please consult an MG Authorised Repairer immediately.
Rear Drive Assist System Fault	Indicates that the rear drive assist system (RDA) has detected a fault. Please consult an MG Authorised Repairer as soon as possible.

Information Centre - Colour Display B *

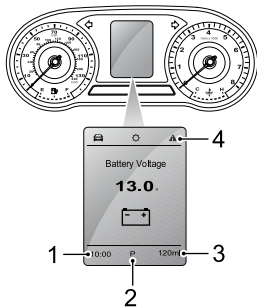

- 1 Digital Clock
- 2 Gear Display and Gear Shift Indication
- 3 Total Mileage
- 4 General Information

Digital Clock

Displays the current time in digital form.

Gear Display and Gear Shift Indication

Displays the current gear position of the transmission (P *, R *, N *, D *, S *, 1, 2, 3, 4, 5, 6 *). When an arrow is displayed to the right of the gear position indicator, it advises the driver to shift gear when the conditions permit. If "EP" is displayed, it indicates that a fault has been detected with the transmission. Please seek an MG Authorised Repairer as soon as possible. Refer to "Starting & Driving" section.

Total Mileage

Displays the total driving mileage of the vehicle.

General Information

The general information function can be selected as follows:

- Press the UP/DOWN/LEFT/RIGHT button on the right hand multifunction steering wheel switch to shift the display items.

INSTRUMENTS AND CONTROLS

- Press the UP/DOWN button on the right hand multifunction steering wheel switch to make adjustment.
- Press the OK button on the right hand multifunction steering wheel switch to confirm or long press OK button to reset.



General information provides the following:

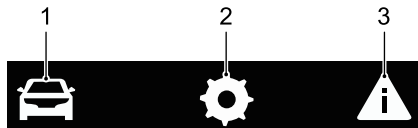

- 1 Trip Computer
- 2 Setting
- 3 Warning Information

Trip Computer

Trip computer functions contain the following:

- **Current Speed:** displays the current vehicle speed in a digital form.
- **Range to Empty:** displays the range that the vehicle can travel before the fuel tank is empty, the value of the range will change after refueling.
- **Current Journey:** displays the range, duration, average speed and average fuel consumption since startup. These values will be reset after a period of power off. It can also be reset by long pressing the OK button on the right hand multifunction steering wheel switch.

- **Accumulated Total:** displays the range, duration, average speed and average fuel consumption since the last reset. It can be reset by long pressing the OK button on the right hand multifunction steering wheel switch.
- **Instantaneous Fuel Economy:** displays the current fuel consumption when the engine is working.
- **Battery Voltage:** displays the 12V Battery Voltage.
- **Tyre Pressures:** displays the current tyre pressure data for each wheel.

Setting

Brightness

Displays the current level and allows adjustment of the backlight brightness.

Note: *This option can only be adjusted when the side lamps are on.*

Speed Warning

Allows the setting of the over-speed alarm threshold.

Next Service

Displays and facilitates the reset of the current vehicle maintenance information.

Warning Information

Displays the warning information or important notes that are currently relevant to the vehicle.

Warning Message

Warning messages and prompts are displayed in the information centre in the instrument pack. Any communications are displayed in 'pop up' messages, these can be divided into the following categories:

- Operating Instruction
- System State Instruction
- System Malfunction Alert

Please follow the instructions displayed in the 'pop up' message or in the case of a warning message, please refer to the relevant section of the owners manual to follow the correct instructions.

INSTRUMENTS AND CONTROLS

The following are a selection of warning messages that may appear in the information centre.

Warning Message	Procedure
Cruise Control Fault	Indicates that the cruise control system has detected a fault. Please consult an MG Authorised Repairer as soon as possible.
Active Speed Limiter Fault	Indicates that the active speed limit system has detected a fault. Contact an MG Authorised Repairer as soon as possible.
Engine Coolant Temperature High	High engine coolant temperature could result in severe damage. As soon as conditions permit, safely stop the vehicle and switch off the engine and contact an MG Authorised Repairer immediately.

Warning Message	Procedure
Engine Coolant Temperature Sensor Fault	Indicates that the engine coolant temperature sensor has failed. As soon as conditions permit, safely stop the vehicle and switch off the engine and contact an MG Authorised Repairer immediately.
Low Oil Pressure	Indicates that the oil pressure is too low, which may result in severe engine damage. As soon as safety permits, stop the car, switch off the engine and check the engine oil level. Contact an MG Authorised Repairer as soon as possible.
Engine Fault	Indicates that a failure has occurred that will effect engine performance and emissions. Contact an MG Authorised Repairer as soon as possible.

INSTRUMENTS AND CONTROLS

1

Warning Message	Procedure
Check Engine	Indicates that a failure has occurred that may severely damage the engine. As soon as conditions permit, safely stop the vehicle, switch off the engine and contact an MG Authorised Repairer immediately.
Stop Start System Fault	Indicates that the Stop/Start intelligent fuel saving system has detected a fault. Please consult an MG Authorised Repairer as soon as possible.
Clutch Switch Fault	Indicates that the clutch switch has detected a fault. Please consult an MG Authorised Repairer as soon as possible.
Gasoline Particular Filter Full	Indicates that the gasoline particular filter is full. Please consult an MG Authorised Repairer as soon as possible.

Warning Message	Procedure
Ignition System Fault	Indicates that the ignition system has detected a fault. Please consult an MG Authorised Repairer immediately.
Start Stop Button Fault	Indicates that the Start Stop button has detected a fault. Please consult an MG Authorised Repairer immediately.
Passive Entry Fault	Indicates that the passive keyless entry (PKE) function has detected a fault. Please consult an MG Authorised Repairer as soon as possible.
ABS Fault	Indicates that the anti-lock brake system (ABS) has failed and the ABS function is about to be disabled. Please consult an MG Authorised Repairer immediately.

INSTRUMENTS AND CONTROLS

Warning Message	Procedure
Brake Fault	Indicates that the brake fluid could be low or a fault has been detected in the Electronic Brake-force Distribution (EBD) system. As soon as safety permits, stop the car, switch off the engine and check the brake fluid level. Contact an MG Authorised Repairer as soon as possible.
Stability Control Fault	Indicates that the stability control system has detected a fault. Please consult an MG Authorised Repairer immediately.
Traction Control Fault	Indicates that the traction control system has detected a fault. Please consult an MG Authorised Repairer immediately.

Warning Message	Procedure
EPB System Fault	Indicates that the electronic parking brake system (EPB) has detected a fault. Please consult an MG Authorised Repairer as soon as possible.
Park Brake Force Not Enough	Indicates that there is an issue with the electronic parking brake, it may not be able to provide adequate clamping force. Contact an MG Authorised Repairer as soon as possible.
Autohold Fault	Indicates that the Autohold System has detected a fault. Please consult an MG Authorised Repairer as soon as possible.
Hill Descent Control Fault	Indicates that the hill descent control system has detected a fault. Please consult an MG Authorised Repairer as soon as possible.

INSTRUMENTS AND CONTROLS

1

Warning Message	Procedure
EPS Performance Reduced	Indicates that the electric power steering system has a general failure and that the steering performance has been reduced. As soon as conditions permit, safely stop the vehicle and switch off the engine. After a short while, start the engine, drive the vehicle a short distance and monitor the operation of the steering, if the message is still displayed or the steering assistance reduced please contact an MG Authorised Repairer immediately.
EPS Assistance Failure	Indicates that the electric power steering system has failed. Please consult an MG Authorised Repairer immediately.

Warning Message	Procedure
Steering Angle Fault	Indicates that the steering angle sensor has failed. Please consult an MG Authorised Repairer as soon as possible.
Steering Angle Uncalibrated	Indicates that the steering angle sensor is not calibrated. Please consult an MG Authorised Repairer as soon as possible.
ESCL Fault	Indicates that a fault has been detected with the Electronic Steering Column Lock (ESCL). As soon as conditions permit, safely stop the vehicle and switch off the engine. Contact an MG Authorised Repairer as soon as possible.
Fuel Sensor Fault	Indicates that fuel sensor has detected a fault. Please consult an MG Authorised Repairer as soon as possible.

INSTRUMENTS AND CONTROLS

Warning Message	Procedure
Airbag Fault	Indicates that the Airbag system has detected a fault. As soon as conditions permit, safely stop the vehicle, switch off the engine and contact an MG Authorised Repairer immediately.
Airbag Lamp Fail	It indicates that the airbag lamp has failed. Please consult an MG Authorised Repairer as soon as possible.
Front Left/Front Right/Rear Left/Rear Right Tyre Sensor Battery Low	Indicates that the Tyre Pressure Monitoring system has detected that a tyre pressure sensor has a low battery. Please consult an MG Authorised Repairer as soon as possible.

Warning Message	Procedure
TPMS Fault	Indicates that the tyre pressure monitoring system has detected a fault. Please consult an MG Authorised Repairer as soon as possible.
12V Battery Charging System Fault	Indicates that the 12V battery charging system has failed. Please consult an MG Authorised Repairer immediately.

Warning Lights and Indicators

Some warning lamps illuminate or flash accompanied by a warning tone.

High Beam Indicator - Blue



The indicator illuminates when the headlamp high beam is turned on.

Side Lamp Indicator - Green



The indicator illuminates when the side lamps are on.

On some models, if the side lamps are switched ON and the driver opens the door, this indicator will flash accompanied by an audible warning chime reminding the driver to switch the side lamps OFF.

Rear Fog Lamp Indicator - Yellow



The indicator illuminates when the rear fog lamps are on.

Front Fog Lamp Indicator - Green *



The indicator illuminates when the front fog lamps are on.

Direction Indicator Lamp - Green



The left and right direction indicator lamps are represented by directional arrows that are located at the top of the instrument pack. When the turning signal lamp flashes, the direction indicator lamp on the corresponding side also flashes. If the hazard warning lamps are operated, both direction indicator lamps will flash together. If either direction indicator lamp in the instrument pack flashes very rapidly, it indicates that the turning signal light on the corresponding side has failed.

INSTRUMENTS AND CONTROLS

Note: Failure of a side repeater lamp will have no effect on the flash frequency of direction indicator lamp.

Anti-theft System Warning Lamp - Red



If no valid key is detected, this lamp illuminates red. Please use the correct key, or put the smart key at the bottom of the centre console cup holder. For specific location requirements, refer to “Alternative Starting Procedure” in “Starting & Driving” section.

If the remote key battery is low, this lamp will flash. Please replace the battery as soon as possible.

Airbag Warning Lamp - Red



If this lamp illuminates, it indicates that there is a failure in the SRS or seat belt. Please seek an MG Authorised Repairer at the earliest opportunity. An SRS or seat belt fault may mean the components may not be deployed in the event of an accident.

Seat Belt Unfastened Warning Lamp - Red



If this lamp illuminates or flashes, it indicates that the seat belt for the driver or front passenger remains unfastened.



This vehicle is equipped with rear seat belt warnings to remind you to ensure any rear seat passengers have fastened their seat belts. The dedicated warning lamp consists of the 3 sections, 1 for each rear seat position, it will illuminate red on every ignition cycle and remain illuminated until a pre-set speed is reached and after a pre-set time period. If all 3 rear seat belts are fastened this lamp will extinguish immediately. When each individual rear seat belt is fastened the colour of that particular seat belt warning lamp will change from red to grey, the other seat positions will remain illuminated red, all 3 seat belt warning lamps will extinguish after the pre-set speed is reached and the pre-set time has been surpassed.

Engine Malfunction Warning - Yellow



This lamp will illuminate if an engine fault occurs that will effect engine performance during driving. Please stop the car as soon as safety permits, switch the engine OFF and contact an MG Authorised Repairer immediately.

Engine Emissions Malfunction Warning - Yellow



If an engine fault occurs that will effect engine performance and emission after starting the vehicle, this lamp will illuminate. Please contact an MG Authorised Repairer as soon as possible.

Engine Coolant Temperature Warning - Red



When the engine coolant temperature warning lamp illuminates red, it indicates that the coolant temperature is high. If the engine coolant temperature continues to rise, the engine coolant temperature warning lamp will flash.

High engine coolant temperature could result in severe damage. Please stop the car as soon as safety permits, switch the engine OFF and contact an MG Authorised Repairer immediately.

Low Oil Pressure Warning - Red



If this lamp illuminates after starting the vehicle, it indicates that the oil pressure is too low, which may result in severe engine damage. Please stop the car as soon as safety permits, switch the engine OFF and check oil level (refer to "Engine Oil Level Check and Top Up" under the "Maintenance"). Contact an MG Authorised Repairer immediately.

Alternator Malfunction Warning - Red



If this lamp illuminates after starting the vehicle, it indicates that the 12v battery charging system has a failure. Please contact an MG Authorised Repairer immediately.

INSTRUMENTS AND CONTROLS

In cases of low battery power, the prompt messages will appear in the information centre. In this case, the system will limit or turn off some electrical devices, please start the vehicle to charge the battery.

Stop/Start Intelligent Fuel Saving System Status

Indicator - Green



If the Stop/Start intelligent fuel saving system is activated, this lamp illuminates to inform the driver that the engine is controlled by the system. When the system is currently unavailable, this lamp flashes three times and then extinguishes.

Stop/Start Intelligent Fuel Saving System

Malfunction Warning Lamp - Yellow



If the Stop/Start intelligent fuel saving system has a failure, this lamp illuminates. Please contact an MG Authorised Repairer as soon as possible.

Cruise Control Indicator - Green/Yellow



If the cruise control function is enabled, the system will enter into the standby state and the indicator illuminates in yellow.

When the cruise control system operates, this indicator illuminates green, indicating the cruise control system is activated.

If a failure in the cruise control system is detected, the indicator will flash in yellow. Please contact an MG Authorised Repairer as soon as possible.

Tyre Pressure Monitoring System (TPMS)

Warning Lamp - Yellow



If this lamp illuminates, it indicates a tyre pressure is low, please check the tyre pressures.

If this lamp flashes first and then remains on after a period of time, it indicates the system has a failure. Please contact an MG Authorised Repairer at the earliest opportunity.

Stability Control/Traction Control System Warning Lamp - Yellow



If this lamp illuminates, it indicates that the stability control/traction control system has a failure. Please contact an MG Authorised Repairer immediately.

If this lamp flashes during driving, it indicates the system is operating to assist the driver.

Stability Control/Traction Control System Off Warning Lamp - Yellow



This lamp will illuminate if the dynamic stability control/ traction control system is manually switched off.

ABS Malfunction Warning Lamp - Yellow



This lamp illuminates to indicate an ABS fault. If an ABS failure occurs while driving, ABS will function

abnormally, but normal braking will still be available. Please contact an MG Authorised Repairer as soon as possible.

Brake System Malfunction Indicator Lamp - Red



If this lamp illuminates, it indicates a failure with the braking system such as brake fluid loss or electronic brake force distribution failure. Please stop the car as soon as safety permits, switch the engine OFF and check brake fluid level (refer to "Brake Fluid Check and Top Up" under the "Maintenance" section). If the brake fluid level appears satisfactory contact an MG Authorised Repairer at the earliest opportunity.

For manual parking brake, the lamp illuminates when the parking brake is applied and extinguishes when it is fully released. If the parking brake is not released, when the vehicle speed exceeds 3 mph (5 km/h), this warning lamp will flash. If the lamp remains on after the parking brake has been released, it indicates that there is a failure in the braking system. Please stop the car as soon as safety permits, switch the engine OFF and contact an MG Authorised Repairer immediately.

INSTRUMENTS AND CONTROLS

Electronic Parking Brake (EPB)/Automatic Parking Status Indicator Lamp - Red/Green *



If this lamp illuminates red, it indicates the electronic parking brake is enabled or in the process of dynamic braking. When it flashes red, it indicates the electronic parking brake has failed. Please contact the MG Authorised Repairer at the earliest opportunity.

When the auto hold system is operating to assist the driver, this lamp illuminates green.

Electronic Parking Brake (EPB) System Malfunction Indicator Lamp - Yellow *



If an electronic parking brake system failure is detected or the system is under diagnosis, the indicator lamp will illuminate. Please contact an MG Authorised Repairer at the earliest opportunity.

Hill Descent Control (HDC) On/Malfunction Indicator Lamp - Green/Yellow



Operating the HDC switch will activate the function, the system will enter the stand by mode and the warning lamp illuminates green, the lamp will extinguish when the system is turned off. If the vehicle is under the control of HDC the green warning lamp will flash.

If the HDC system detects a fault or fails, the warning lamp illuminates yellow. Please contact an MG Authorised Repairer immediately.

Electric Power Steering System (EPS)/ Electronic Steering Column Lock (ESCL) Warning Lamp - Yellow/Red *



The warning lamp is used to indicate electric power assisted steering failure or electronic steering column lock failure.

When this lamp illuminates yellow, it indicates the electric power assisted steering system has a general failure and the performance is reduced. Please stop the car as soon as safety permits. If the lamp still illuminates after restarting the vehicle and driving for a short while, please contact an MG Authorised Repairer immediately.

When this lamp illuminates red, it indicates that the EPS has a failure relevant to the steering angle sensor. Please contact an MG Authorised Repairer at the earliest opportunity.

When this lamp illuminates red and flashes, it indicates the electric power assisted steering system has a severe failure and heavy steering. Please contact an MG Authorised Repairer immediately.

When the lamp illuminates yellow and flashes, it indicates the electric steering column lock * has a failure. Please stop the car as soon as safety permits, switch the engine OFF and contact an MG Authorised Repairer immediately. If this lamp extinguishes after flashing for a while, it indicates that the steering wheel is locked, please attempt to rotate the steering wheel to remove any adverse loads.

Low Fuel Warning Lamp - Yellow



The warning lamp illuminates yellow when the fuel remaining in the fuel tank is low. If possible, please refuel before the low fuel warning lamp illuminates.

When the fuel level continues to fall, this lamp flashes. When fuel is added to the tank and the fuel level rises above the alert limit, this lamp extinguishes. If it does not extinguish, please contact an MG Authorised Repairer for service as soon as possible.

Note: *When driving on steep or rough roads while the fuel level is low, the warning lamp may illuminate.*

System Fault Messages Indicator - Yellow *



This indicator is used to alert the driver to the fact that there is a warning stored in the vehicle IPK system. Please refer to "Information Centre" in this section for these failures.

INSTRUMENTS AND CONTROLS

Active Speed Limit System Warning Lamp — Yellow



This warning lamp illuminates if an active speed limit system failure is detected. Please contact an MG Authorised Repairer as soon as possible.

Active Speed Limit System Indicator — Red



When the active speed limit system is armed or active, if the target vehicle speed is currently set, this indicator illuminates and displays the target vehicle speed value.

When the active speed limit system is working, if the current speed exceeds the set target speed, this indicator will flash, and the system will immediately reduce the speed to below the target speed. The active speed limiter only uses engine braking to reduce speed - it is not a substitute for physical brake application. If the vehicle needs to be slowed or stopped quickly the brake pedal **MUST** be applied.

Particulate Filter Warning Lamp - Yellow *



When this lamp illuminates yellow, it indicates that the particulate filter requires regeneration. Please drive the vehicle above 50mph until the light is no longer illuminated, and then normal usage can be resumed.

Note: *During particulate filter regeneration the engine will run unevenly and at reduced power, this will cease after a successful regeneration.*

When this lamp flashes, it indicates that the particulate filter is full, the engine malfunction indicator lamp illuminates at the same time. Please contact an MG Authorised Repairer immediately. Please note if the warning is ignored, the vehicle will enter a reduced performance mode and may subsequently be immobilised.

Please refer to “Catalytic Converter and Particulate Filter” in “Starting & Driving” section.

Lights and Switches

Master Lighting Switch

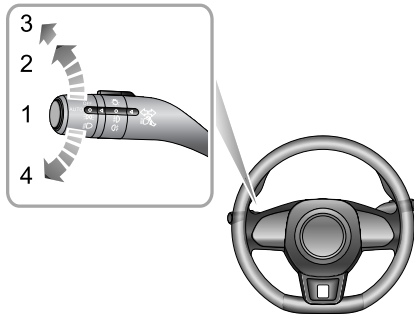

- 1 AUTO Lamp
- 2 Side Lamps and Switch Illumination
- 3 Dipped Headlamps
- 4 Lights OFF

AUTO Lamp

When the START/STOP Switch is in the ACC position, the auto lighting system defaults to the ON position (1). The auto lighting system will automatically switch the side lamps and switch illumination on and off according to the intensity of current ambient light.

With the START/STOP Switch switched to the ON position, the auto lighting system defaults to the ON position (1). The auto lighting system will automatically switch the side lamps, switch illumination and dipped headlamps on and off according to the intensity of current ambient light.

Note: *This function is realized by fitting a sensor capable of monitoring exterior lighting conditions in real time on your vehicle. The sensor is fitted in the centre of the fascia panel near the windscreen in some models. DO NOT mask or cover this area, or headlamps may automatically go on when not necessary.*

INSTRUMENTS AND CONTROLS

Side lamps and Switch Illumination

Turn the master lighting switch to position 2 to operate the side lamps and switch illumination. With the START/STOP Switch in the OFF position if the lighting switch is in position 2 and the driver's door opened an audible warning will sound to alert the driver, the side lamps will remain on.

Dipped Headlamps

When the START/STOP Switch is in the ON position, turn the master lighting switch to position 3 to operate the dipped headlamps and side lamps.

Lights Off

Turn the master lighting switch to position 4, this will switch off all lamps, releasing the switch will allow it to return to the AUTO switch position.

Follow Me Home

After the START/STOP Switch is turned off, pull the lighting stalk switch towards the steering wheel. This will enable the Follow Me Home function, dipped beam

headlamps and side lamps will illuminate depending upon the vehicle configuration. It can be set in the 'Comfort and Convenience' in the Vehicle Settings on the entertainment display.

Daytime Running Lamp

The daytime running lamps turn on automatically when the START/STOP Switch is in the ON position. When the side lamps are switched on, the daytime running lamps extinguish automatically.

Find My Car

After the vehicle has been left in a locked condition for a few minutes pressing the lock button again on the remote key will enable the Find My Car function. This function will identify the car by means of an audible and visual alert. Pressing the Lock button on the handset again will suspend this operation. Pressing the Unlock button will cancel this operation. This feature can be set via 'Comfort and Convenience' in the Vehicle Settings on the entertainment display.

Headlamp Levelling Manual Adjustment

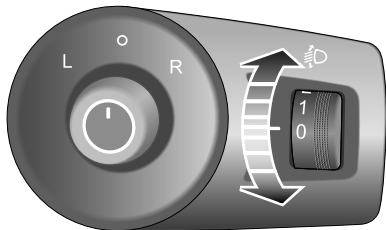

Position 0 is the initial position of the headlamp levelling adjustment switch. The headlamp levelling adjustment can be made as per the following table according to the vehicle load.

Location	Load
0	Driver, or driver & front passenger.
1	All the seats occupied with no load.
2	All the seats occupied plus an evenly distributed load in the boot, or driver with full load.
3	Driver only, plus an evenly distributed load in the boot.

INSTRUMENTS AND CONTROLS

Fog Lamp Switch



Fog lights should only be used when visibility is below 100m - other road users could be dazzled in clear conditions.

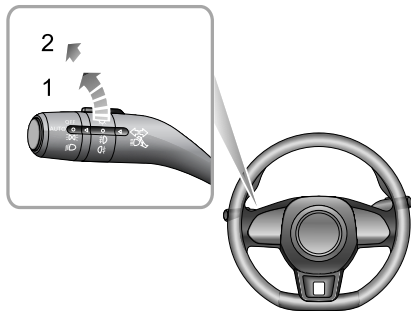

Front Fog Lamps *

With the START/STOP Switch in the ON position and the side lamps on, turn the fog lamp switch to position 1, this

will turn on the front fog lamps. The indicator illuminates in the instrument panel when the front fog lamps are on.

Rear Fog Lamp

With the START/STOP Switch in the ON position and the headlamps or front fog lamps on, turn the fog lamp switch to position 2, this will turn on the rear fog lamp, release the switch to allow it to return to the last position. The indicator illuminates in the instrument panel when the rear fog lamp is on.

Direction Indicator/Main Beam Switch



Take care not to dazzle oncoming vehicles when driving using main beam headlamps.

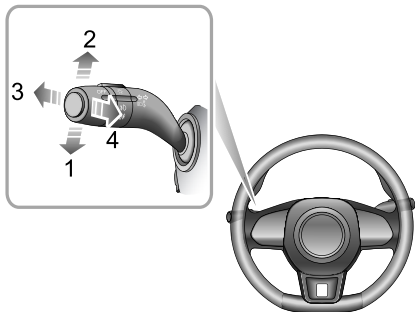

Direction Indicators

Move the lever down to indicate a LEFT turn (1). Move the lever up to indicate a RIGHT turn (2). The corresponding

GREEN indicator lamp in the instrument pack will flash when the turning signal lamps are working.

Rotating the steering wheel will cancel the indicator operation (small movements of the steering wheel may not operate the self cancelling). To indicate a lane change, move the lever briefly and release, the indicators will flash three times and then cancel.

Headlamp High/Low Beam Switching

With the START/STOP Switch in the ON position and the master lighting switch turned to position 3, or the auto function has switched the lights on, push the lever (3) towards the instrument panel to turn on headlamp high beams. The high beam indicator lamp in instrument pack illuminates, press the lever (3) again to switch to headlamp low beams.

High Beam Flash

To briefly flash the high beam on and off, pull the lever towards the steering wheel (4) and then release.

INSTRUMENTS AND CONTROLS

Hazard Warning Lamp

Press the hazard warning lamp button  to turn on the hazard warning lamps. The turning signal lamps and direction indicator lamps will flash together. Press the button again to switch off the hazard warning lamps. All turning signal lamps and direction indicator lamps will stop flashing. For more details and location refer to 'Emergency Information' 'Hazard Warning Devices'.

Wipers and Washers

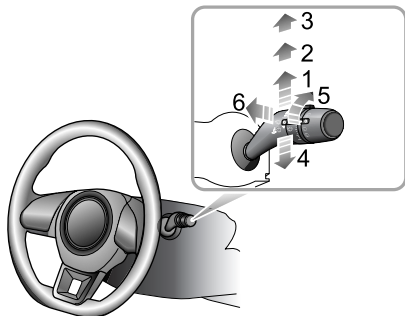

Windscreen Wiper Operation

The wipers and washers will only operate with the START/STOP Switch in the ACC/ON/RUNNING position.

Operate the lever to select different wipe speeds:

- Intermittent wipe (1)
- Slow wipe (2)

- Fast wipe (3)
- Single wipe (4)
- Automatic wipe interval adjustment * / Rain sensor sensitivity adjustment *(5)
- Programmed wash/wipe (6)

Intermittent Wipe

By pushing the lever up to the Intermittent wipe position (1), the wipers will operate automatically. Turn the switch (5) * to adjust the intermittent wipe frequency. This speed will also change with the vehicle speed. As the vehicle speed increases, the wiper frequency increases. As the vehicle speed decreases, the wiper frequency decreases.

Some models are equipped with a rain sensor fitted to the interior rear view mirror base to detect varying amounts of water on the outside of the windscreen. With automatic wipe, the vehicle will adjust the wiping speed according to the signals provided by rain sensor. Turn the switch (5) to adjust the sensitivity of rain sensor. As the sensitivity increases, the wiping interval decreases.

Note: *Immediately operating the wiper one time can be achieved by increasing the sensitivity of rain sensor.*

INSTRUMENTS AND CONTROLS

If the rain sensor detects a continuous rainwater, the wiper will keep working. When no rain is detected, it is recommended to switch off automatic wipe.

Slow Wipe

By pushing the lever up to the slow wipe position (2), the wipers will operate slowly. Move the lever to re-select the wipe speed.

Fast Wipe

By pushing the lever up to the fast wipe position (3), the wipers will operate fast. Move the lever to re-select the wipe speed.

Single Wipe

Pressing the lever (4) down and releasing will operate a single wipe, if the lever is held down, the wipers will operate until the lever is released.

Note: *When the car is stationary, if the bonnet is opened, the front wiper/washer will stop work immediately.*

IMPORTANT

- Avoid operating the wiper on a dry windscreen.
- In freezing or extremely hot weather conditions, make sure that the wiper blades are not frozen/adhered to the windscreen.
- In winter, remove snow or ice from around the arms and blades, including the wiped area of the screen.

Programmed Wash/Wipe

Pulling the lever toward the steering wheel (6) will operate the windscreen washers. After a short delay, the wipers will commence operating in conjunction with the washers.

Note: *The wipers continue operating for a further three wipes after the lever is released. After several seconds, there will be a further wipe to remove any fluid draining down the screen.*

IMPORTANT

If the washers fail to deliver the screen wash solution (dirt or ice may have blocked the jets), release the lever immediately. This will prevent the wipers from operating, and the consequent risk of visibility being impaired by dirt smearing across the unwashed windscreen.

Rear Window Wiper Operation

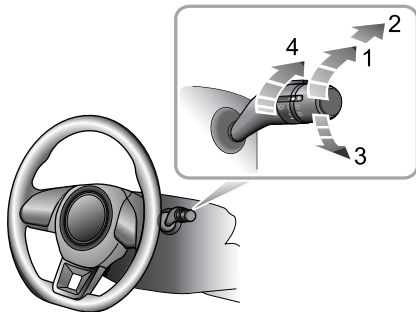

- Intermittent wipe (1)
- Wash and wipe (2)
- Wash and wipe (3)
- Intermittent wipe frequency adjustment (4)

The rear window wiper and washer will only operate with the START/STOP Switch in the ACC/ON/RUNNING position. Turn the rear window wiper switch to intermittent wipe (1), the rear window wiper will operate,

INSTRUMENTS AND CONTROLS

after 3 consecutive wipes, the wipers will enter into intermittent mode. The time period between the wipes can be increased/decreased via the intermittent wipe frequency adjustment switch (4).

Turn the rear window wiper switch to wash and wipe (2) position and hold, the rear window wiper and washer will operate, the rear window wiper wipes quickly. release the switch allowing it to return to intermittent wipe (1), the rear window washer will stop operating, and the wiper wipes slowly, change the stalk switch position 4 to adjust the wipe speed.

Turn the rear window wiper switch to wash and wipe (3) and hold, the rear window wiper and washer will operate. release the switch allowing it to return to OFF position, the rear window washer will stop operating, and the rear window wiper wipes for 3 times, after several seconds, the wiper will wipe once more to remove the washer fluid on the windscreen.

Note: When the tailgate is opened, rear window wiper operations will be disabled.

Note: When the windscreen wipers are switched on, if the shift control lever is moved to, or in the R position, the rear window wiper will operate.

Steering System

Adjustment of Steering Column



DO NOT attempt to adjust the angle of the steering column while the vehicle is in motion. This is extremely dangerous.

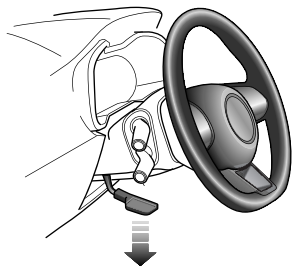

To adjust the angle of the steering column to suit your driving position:

- 1 Fully release the locking lever.
- 2 Hold the steering wheel in both hands and tilt the steering column up or down to move the wheel into the most comfortable position.
- 3 Once a comfortable driving position has been selected, pull the locking lever fully up to lock the steering column into its new position.

INSTRUMENTS AND CONTROLS

Electric Power Steering



If the electric power steering fails or cannot operate the steering will appear very heavy, this will affect driving safety.

The electric power steering system only works when the vehicle is started. The system operates via a motor with assistance levels automatically adjusted based on vehicle speed, steering wheel torque and steering wheel angle.

IMPORTANT

Holding the steering wheel on full lock for long periods will result in a reduction in power assistance causing a heavier feel to the steering for a short period of time.

Steering Mode Switching

The electric power steering system provides 3 different steering modes:

- 1 Normal: provides moderate power assistance.
- 2 Urban: provides a high level of assistance, with a light feel.
- 3 Dynamic: provides low level power assistance, with a heavier feel.

The steering mode is selectable for vehicle speeds up to 60 mph (100 km/h) through the touch screen interface.

Note: Steering mode selection is only available when the steering wheel is not being turned. Any changes made in this state will not take effect until the steering wheel is straight ahead.

Electric Power Steering (EPS) Warning Lamp

See "Warning Lamps and Indicators" under the "Instruments and Controls" section.

Horn



Press the horn button area on the steering wheel (as indicated by the arrow) to operate the horn.

Note: *The vehicle horn switch location and the driver's airbag are located in close proximity on the steering wheel. The illustration shows the position of the horn switches, please ensure that you press in this area to*

avoid any potential conflict with the operation of the airbag.

IMPORTANT

To avoid possible SRS issues, please do not press with excessive force or hit the airbag cover when operating the horn.

INSTRUMENTS AND CONTROLS

Mirrors

Door Mirrors

Note: Objects viewed in door mirrors may appear further away than they actually are.

Electric Door Mirror Glass Adjustment

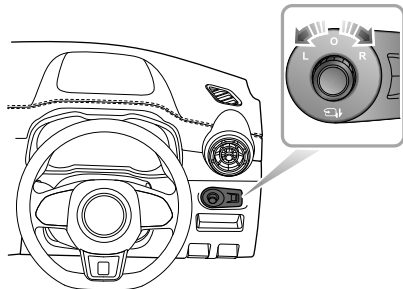

- The mirror adjustment function will work with the power system in all modes, including OFF, ACC and ON/RUNNING.
- Rotate the knob to select left (L) or right (R) rearview mirror.
- Move the knob in the desired direction to adjust the angle of the exterior mirror glass.
- Upon completion of the adjustment, rotate the knob back to the central position, this will ensure no accidental adjustment of the mirror.

Heating Elements *

The door mirrors have integral heating elements which disperse ice or mist from the glass. The heating elements operate while the Heated Rear Window  is switched on.

Note: The heating elements of rear window and mirror will only work when the power system is running.

Mirror Folding

The mirrors can be folded back towards the side windows into a 'park' position to enable the car to negotiate narrow openings and avoid collisions.

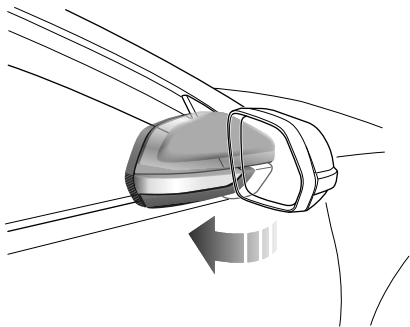

Manual Folding of Door Mirror *

For vehicles not fitted with the electric door mirror fold option, the exterior mirrors can only be folded backwards manually.

Electric Folding of Door Mirror *

For vehicles fitted with electric door mirror folding, rotate the knob to the middle position, and push the knob down.

The door mirrors will be folded automatically. Pushing the knob downwards again will return the mirrors to their original position.

Operating the key fob lock/unlock buttons will fold/unfold the door mirrors.

Note: *Electrical folding door mirrors that have been moved from their positions by manual or accidental means must be reset by operating the knob to complete fold and deployment one time.*

IMPORTANT

- Door mirror glass adjustments and door mirror folding are operated by electrical motors. Operating them directly by hand may damage the internal components.
- Washing or flushing door mirrors with high pressure water jets or car washes may result in electrical motor failure.

INSTRUMENTS AND CONTROLS

Interior Rearview Mirror

Adjust the body of the interior rearview mirror to achieve the best possible view. The anti-dazzle function of the interior rearview mirror helps to reduce glare from the headlamps of following vehicles at night.

Manual Anti-dazzle Interior Rearview Mirror

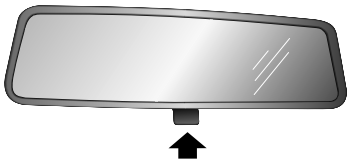

Move the lever at the base of the mirror forward to 'dip' the mirror and achieve the anti-dazzle function. Normal visibility is restored by pulling the lever back again.

Note: *In some circumstances, the view reflected in a 'dipped' manual mirror can confuse the driver as to the precise location of following vehicles.*

Sunvisor



The vanity mirror on the driver side should only be used when the car is stationary.

Sunvisors (1) are arranged on the roof ahead of both the driver and the front passenger. Some models have vanity mirror (2), depending on the vehicle configuration. For the models which have vanity mirror, pull the sunvisor downward and slide the cover aside to use the vanity mirror.

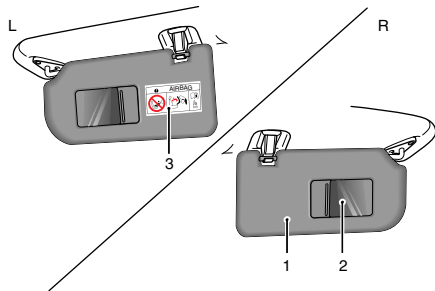

Note: Warnings and instructions on use of child restraint (3) are attached to both sides of the passenger sunvisor.

NEVER use a rearward facing child restraints on a seat protected by an **ACTIVE AIRBAG** in front of it, **DEATH** or **SERIOUS INJURY** to the **CHILD** can occur. Refer to 'Disabling the Passenger Airbag'.

INSTRUMENTS AND CONTROLS

Windows

Power Operated Window Switch

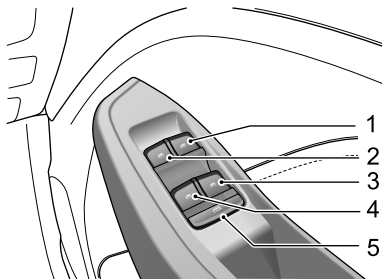

- 1 Front Right Window Switch
- 2 Front Left Window Switch
- 3 Rear Right Window Switch
- 4 Rear Left Window Switch
- 5 Rear Window Isolation Switch

Window Operation



Ensure children are kept clear when raising or lowering a window.



Improper use or activation of the electric windows by children could cause serious harm or even death. It is the responsibility of the driver and adult passengers to ensure that when carrying children the necessary steps are taken to isolate the window operation. This should include the removal of the key when children are left alone in the vehicle.

Push the switch (1-4) down to lower, and pull the switch up to raise the window. The window will stop moving as soon as the switch is released (unless the 'One-Touch' function is active).

Note: The front and rear passenger windows can also be operated by individual window switches, mounted on each door. The rear window switches will not be operated if the rear window isolation switch has been activated.

Note: *The electric window can be operated with the vehicle power system in the ACC, ON and RUNNING positions. (For safety: doors should be closed).*

Rear Window Isolation Switch

Press the button (5) to isolate the rear window controls, press again to restore control.

Note: *It is recommended that you ISOLATE the rear window switches when carrying a child.*

“One-Touch” Down

The driver's window control switch (1) has 2 positions. Short press the window control switch to the "2" position and release. The window automatically descends to fully open. Window movement can be stopped at desired position at any time by briefly operating the switch again.

“One Touch” Up with “Anti-Trap” *

The driver's window control switch (1) has the “one-touch” up function. Lifting the switch to the "2" position for a short time and releasing will automatically

close the window completely. Window movement can be stopped at a desired position at any time by briefly operating the switch again.

The “Anti-Trap” function is a safety feature which prevents the window from fully closing if an obstruction is sensed - if this happens the window will open slightly to allow the obstruction to be removed.

Note: *DO NOT operate the power window controls continuously several times in a short time frame, otherwise the power window controls may be disabled to protect the motor. If this occurs, please wait a few seconds until the motor cools down. In the case of the driver's window with "One Touch and Anti-Trap" please wait 30 seconds prior to operation. In some cases it may take 30 minutes to completely cool down, during which time the negative battery lead should not be disconnected.*

Note: *If the battery is disconnected, the “One-Touch” and “Anti-Trap” features will be lost. To restore this feature, fully open and then fully close the window holding the switch for 5 seconds in the closed position.*

INSTRUMENTS AND CONTROLS

Sunroof *

The sunroof consists of two glass panels, only the front section can be opened by sliding or tilting. The sunshade can be opened or closed as a complete unit.

Instructions



DO NOT allow passengers to lean out of an open sunroof whilst the vehicle is in motion. Injuries may occur from objects such as tree branches.



Safety of the vehicle occupants must be observed at all times. DO NOT allow limbs to be placed in the moving path of the sunroof at any time, injury may occur.

- DO NOT use abrasive materials to clean the sunroof glass. Use only propriety glass cleaner or alcohol based solvent.
 - DO NOT hold the operating switch in the open/close position for any length of time after operation is complete, this could damage the electrical components.
 - Clean the sunroof regularly to maintain operation and performance. Visit an MG Authorised Repairer for service as required.
- Avoid fully opening the sunroof during rain showers.
 - It is advised not to open the sunroof at high speeds.
 - Where possible, please clean off any residual water or raindrops off the sunroof prior to opening. Failure to do so may result in water entering the car.

Sunroof Operation

The sunroof will operate when the vehicle power system is in the ACC or ON/RUNNING modes.

Sunroof Glass Operation

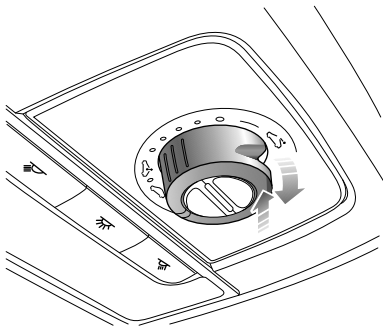

Opening the Sunroof Glass using Tilt

With the sunroof glass fully closed, press the rear part of the switch in the direction of the arrow as indicated in the graphic to fully 'tilt' the glass to the open position. Operation can be interrupted at the desired point by pressing the switch again.

Closing the Sunroof Glass from Tilt

Pull down the rear of the switch to automatically close the sunroof in the direction as indicated by the arrow. Briefly pull down on the switch again will interrupt the operation at the desired position.

To manually close the sunroof, pull down the rear of the switch in the direction as indicated by the arrow and hold, until the sunroof reaches the desired position.

Opening the Sunroof Glass by Sliding



Rotate the switch completely clockwise and hold until the sunroof slides fully open. To partially open the sunroof, place the switch in the required range position.

INSTRUMENTS AND CONTROLS

Closing the Sunroof Glass by Sliding



Rotate the switch completely counterclockwise, the sunroof will slide fully closed. To partially close the sunroof, place the switch in the required range position.

Sunroof Sunshade Operation

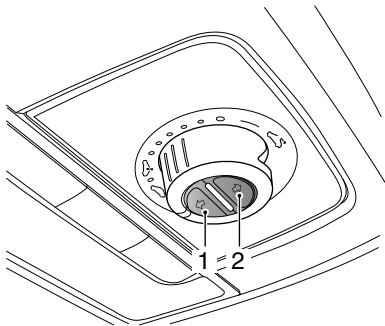

Opening the sunshade.

Short press the button (2) to automatically open the sunshade to its full extent. Short press the button at any time to cancel the request and stop the sunshade at that position.

To manually open the sunshade, press and hold the button until the sunshade reaches the desired position, then release it.

Closing the Sunshade

Short press the button (1) to automatically close the sunshade completely. Short press the button at any time to cancel the request and stop the sunshade at that position.

To manually close the sunshade, press and hold the button until the sunshade reaches the desired position, and release it.

Note: *If the vehicle is to be parked in direct sunlight for a length of time it is recommended that the sunshade be closed to protect the interior trim components from damage, and to help regulate the in car temperatures.*

Anti-pinch Function

The sunroof and sunshade feature an “Anti-Pinch” function, this is a safety feature which prevents the sunroof or sunshade from fully closing whilst in the automatic mode if an obstruction is sensed - if this happens the sunroof/sunshade will open slightly to allow the obstruction to be removed.

Forcibly Closing the Sunroof (over-riding the anti pinch)

To forcibly close the sunroof glass after an anti-pinch intervention, gently pull the rear of the switch downwards within 5 seconds and hold in position until the sunroof glass is fully closed.

Note: The anti pinch function is suspended during this operation.

Forcibly Closing the Sunshade (over-riding the anti pinch)

To forcibly close the sunshade after an anti-pinch intervention, press the close button within 5 seconds and hold it until the sunshade is fully closed.

Note: The anti pinch function is suspended during this operation.

Note: The anti-pinch function only works when closing the sunroof during the slide operation.

Sunroof Initialisation

In the event of a power failure or battery disconnection when the sunroof glass or sunshade is in motion, the sunroof/sunshade will require initialisation when the power is restored.

To carry out the sunroof glass initialisation operation:

Fully close the glass - gently pull the rear of the switch downward and hold in position for 10 seconds, the sunroof will open a preset amount and stop, it will then close automatically- the sunroof glass is then initialised. During the whole process, the switch must remain in the pulled down position.

INSTRUMENTS AND CONTROLS

To carry out the sunshade initialisation operation:

Fully close the sunshade - press the close switch and hold in position for 10 seconds, the sunshade will open a preset amount and stop, it will then close automatically- the sunshade is then initialiaised. During the whole process, the switch must remain pressed.

Interior Lights

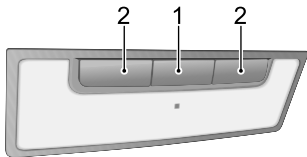

Press any one of buttons (2) to switch on the corresponding lamp, and press it again to switch the lamp off.

Automatic Operation

Press the interior lights switch button (1) to turn on automatic operation, and press it again to turn off the function.

Interior light illumination occurs automatically whenever the following occur.

- The car is unlocked.
- Any door or the tailgate is opened.

- The vehicle power system is switched off, providing the sidelights have been illuminated during the previous 30 seconds.

Note: *If a door or the tailgate is open for more than 15 minutes, the front interior lamp will be switched off automatically to avoid battery drain.*

INSTRUMENTS AND CONTROLS

Power Socket



Please ensure the socket blanking plug is inserted when the power socket is not in use. This will ensure no debris or foreign objects enter the socket preventing its use or cause short circuits.



The 12V power socket has a voltage rating of 12V, and the maximum power of 120 Watt, please DO NOT use any electrical appliance that exceeds this rating.



Extended use of the accessory power socket and USB socket when the engine is switched off will cause premature discharging of the vehicle battery.

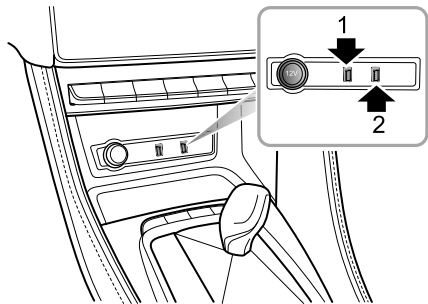

The 12V power socket is located under the shift control knob assembly in the centre console. It can be used as a power supply when the START/STOP Switch is in the ACC or ON/RUNNING positions when the blanking plug is removed.

Located to the right of the power socket are two USB ports. Both of them can be used to provide a 5V power supply or a data transmission connection.

INSTRUMENTS AND CONTROLS

1

Note: The vehicle is not supplied with a cigar lighter. If required please contact your local MG Authorised Repairer.

There are two USB ports located at the rear of the centre console, these provide 5V voltage when serving as the power outlet.

Note: Due to differences in configuration the charging function of the USB port will be slower.

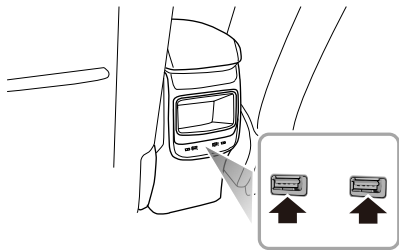

There is also one USB port located in the rear view mirror mounting trim cover, this provides a 5V power source.

INSTRUMENTS AND CONTROLS

Storage Devices

Instructions

- Please close all storage devices when the vehicle is in motion. Leaving these storage devices open may cause personal injury in cases of a sudden start-off, emergency braking and a car accident.
- Do not place flammable materials such as liquid or lighters in any storage devices. The heat in hot conditions may ignite flammable materials and lead to a fire.

Glove Box

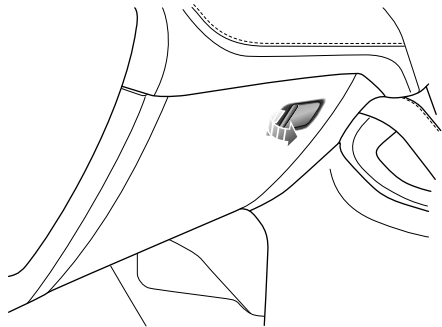

To open the glove box, pull the handle on the glove box cover (as indicated by the arrow).

Push the box cover forward to close the glove box. Make sure the glove box is fully closed when the vehicle is in motion.

Card Box

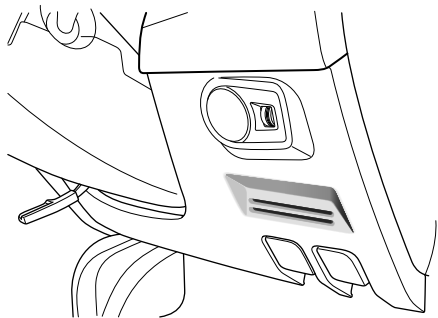

Located in the driver side lower dash trim panel.

Centre Console Armrest Box

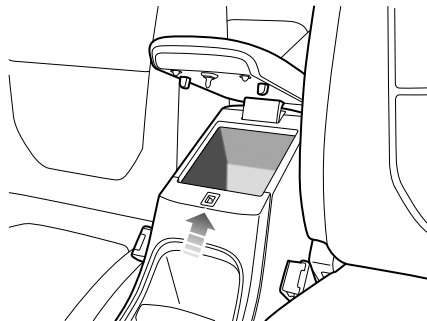

Lift the armrest (arrowed) to open the compartment cover.
Put the cover down to close it.

INSTRUMENTS AND CONTROLS

Loadspace



DO NOT place articles on the rear parcel shelf, they could move causing personal injury in the event of an accident , emergency braking or hard acceleration.

The spare wheel/tyre repair kit and tool kit are stowed beneath the loadspace carpet, lift the carpet for access. Always refit the carpet after use.

In addition, The loadspace carpet height can be adjusted by using the carpet bracket (figure 1, 2).

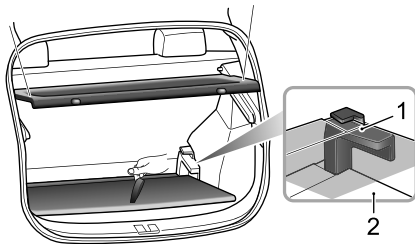

The rear parcel shelf is connected to the tailgate using straps and hooks. When opening the tailgate, the shelf will automatically be raised.

Cup Holder



Do not place hot drinks in the cup holder whilst driving. Spillage may result in personal injury or damage.

Centre Console Cup Holder(EPB)

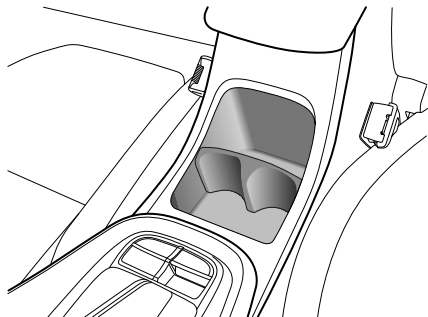

The centre console cup holder is situated at the front end of the centre console armrest assembly.

Centre Console Cup Holder(IPB)

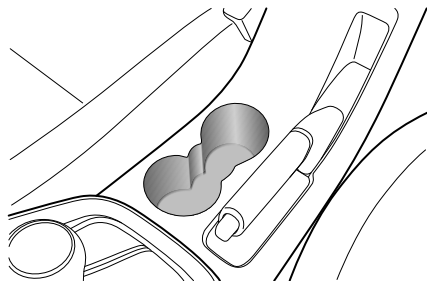

The centre console cup holder is situated at the front end of the centre console armrest assembly.

INSTRUMENTS AND CONTROLS

Roof Luggage Rack *



Roof loads *MUST NOT* exceed the maximum authorised load. This may lead to injury or vehicle damage.



Loose or improperly fixed loads may fall from the roof luggage rack and lead to an accident or cause people injury.



When heavy or large items are carried on the roof luggage rack it may lead to changes in steering, handling and braking characteristics. Please avoid sharp manoeuvres, heavy braking and excessive acceleration.

Pay attention to the following in using the roof luggage rack:

- Secure loads toward the front of the roof as far as possible. distribute loads evenly.
- DO NOT use automatic car washes with loads on the roof luggage rack.

- The overall height of the car is different when loads are fitted to the roof luggage rack. Please ensure there is adequate clearance when entering tunnels and garages.
- Ensure the loads carried by the roof luggage rack do not impede operation of the sunroof, roof antenna of tailgate opening.
- When installing or removing a piece of loading equipment, follow the instructions provided by the manufacturer of the loading equipment.

Maximum Authorised Load for the Roof

The maximum authorised load for the roof is 75 kg, this includes the weight of the roof loads and that of the loading equipment installed.

Ensure you are aware of the weight of loads, and weigh them when necessary. Never exceed the maximum authorised load for the roof.

Periodical Check

Always check the condition of the bolt connectors and fastenings before use. Periodically check the bolt connectors and fastenings for security.

Air Conditioning and Audio Systems

70 *Ventilation*

73 *Electronic Temperature Control*

79 *Entertainment Player*

AIR CONDITIONING AND AUDIO SYSTEMS

Ventilation

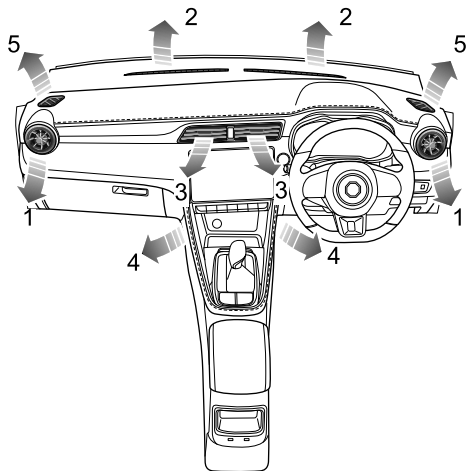

- 1 Side Vents
- 2 Windscreen/Defrost Vents
- 3 Centre Vent
- 4 Front Footwell Vents
- 5 Front Side Window Vents

AIR CONDITIONING AND AUDIO SYSTEMS

The heating, ventilation and air conditioning * system provides fresh, cooling * or heated air to the interior of the car. Fresh air is drawn in through the air intake grille under the front windscreen and the air conditioning filter.

Always keep the air intake grille clear of obstructions such as leaves, snow or ice.

A/C Particle/Pollen Filter

The particle/pollen filter helps to keep the car interior free from pollen and dust. To remain fully effective, the filter should be replaced at the recommended service interval.

Vents

Centre Vents

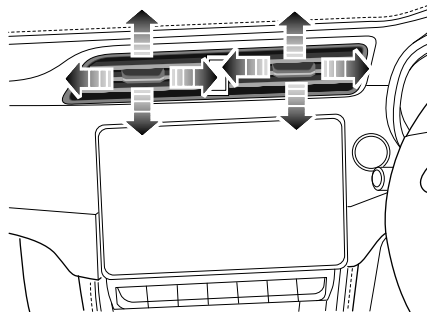

Slide the button in the centre of the louvres completely to the left or right to open or close the vent, adjust this button to direct the flow of air.

Toggle the button at the centre of each vent up and down, left and right to regulate the air direction.

AIR CONDITIONING AND AUDIO SYSTEMS

Side Vents

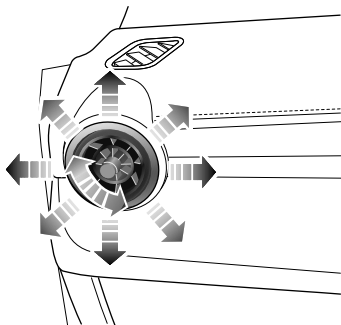

Rotate the centre thumb-wheel clockwise or anti-clockwise to open or close the vent. Toggle the centre thumb-wheel up, down, left or right to adjust the air direction.

AIR CONDITIONING AND AUDIO SYSTEMS

2

Electronic Temperature Control

Infotainment Screen Control Interface

With A/C Cooling *

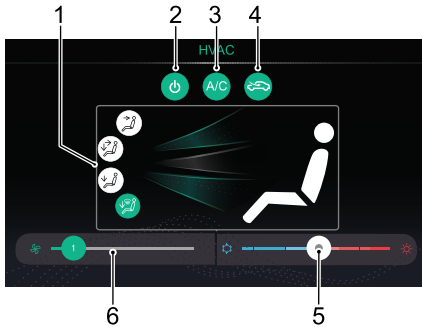

- 1 Air Distribution Mode
- 2 System On/Off
- 3 A/C Cooling On/Off
- 4 Air Recirculation Mode
- 5 Temperature Control
- 6 Blower Speed Control

Without A/C Cooling *

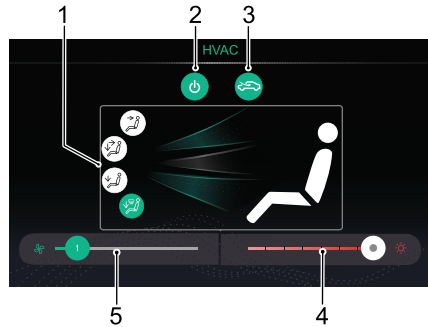

- 1 Air Distribution Mode
- 2 System On/Off
- 3 Air Recirculation Mode
- 4 Temperature Control
- 5 Blower Speed Control

AIR CONDITIONING AND AUDIO SYSTEMS

System On/Off

Touch the System On/Off Button on the control interface to switch the system on, all functions will revert to the state before shutdown. Touch again to switch off.

Note: *Turning off the infotainment screen will not affect the operation of the system*

A/C Cooling On/Off *

Touch the A/C Cooling On/Off Touch Button to turn the A/C cooling function ON/OFF.

Note:

- 1** *The cooling/heating mode of the air conditioning will only operate when the engine is running.*
- 2** *The heating/ventilation function is still available, when the A/C cooling is switched off.*
- 3** *A small amount of water may remain in the air conditioner after usage, this may produce a peculiar smell. If this is a particular issue, it is recommended to switch off the cooling function*

and run the blower for a while with the engine running prior to switching off.

Air Recirculation Mode

Touch the recirculation button on the control interface to operate the air recirculation function, the image displayed in the switch will change to display your chosen position (external or internal circulation), if the air intake is closed the air inside the car is recirculated, preventing the entry of traffic fumes.

Recirculation mode is automatically activated when the screenwashers are used or reversing.









Note: *Leaving the system in recirculation mode can cause the windscreen to mist. If this happens, switch off recirculation and turn the controls to maximum demisting.*

Air Distribution Mode

Select the corresponding Air Distribution Mode Touch Button as required to regulate the air distribution mode.

AIR CONDITIONING AND AUDIO SYSTEMS

2

Touch Button	Icons on Interface	Air Distribution Mode
		To 'face'
		To 'face' and 'feet'
		To 'feet'
		To 'feet' + 'windscreen'

To 'face'. Directs air to the side, centre and centre console vents.

To 'face' and 'feet'. Directs air to the footwell, side, centre and centre console vents.

To 'feet'. Directs air to the footwell vents.

Note: In this mode, a small amount of airflow will be directed to the side, front side window and windscreen/defrost Vents.

To 'feet' + 'windscreen'. Directs air to the footwell, windscreen/defrost and front side window vents.

Note: In this mode, a small amount of airflow will be directed to the side vents.

Blower Speed Control

Slide the blower speed segments left or right to regulate the blower speed, the lowest position is 1.

Touch the blower speed segment to quickly set the required blower speed.

Temperature Control

Slide the temperature segment left or right to regulate the temperature of the air supplied by the vents.

Touch the temperature segment to quickly set the required temperature.

AIR CONDITIONING AND AUDIO SYSTEMS

Control Panel

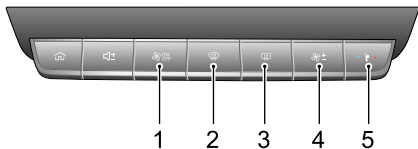

- 1 A/C Control Shortcut
- 2 Defrost/Demist Button
- 3 Heated Rear Window Button
- 4 Blower Speed Control Button
- 5 Temperature Control Button

A/C Control Shortcut



Short press the A/C control shortcut to display the air conditioning interface on the infotainment screen.

Long press the A/C control shortcut to switch the system on, all functions will revert to the state before shutdown. Long press again to switch off.

Blower Speed Control Button



Press the blower speed control button upward or downward to regulate the blower speed.

Temperature Control Button



Press the temperature control button upward or downward to regulate the temperature of the air supplied by the vents.

Defrost/Demist



Press Defrost/Demist Button on the control panel, the indicators on the button and display illuminate, the A/C cooling and external circulation functions are switched on, and the system enters the most effective warm or cold air setting to clear the windshield and side window.

Pressing the Defrost/Demist Button or the touch button on the display again will exit the defrost/demist state, the indicator goes out, and the system will return to the previous state.

In the defrost/demist mode, operation of the A/C cooling on/off button will switch the compressor on or off; operation of the air circulation mode button will switch between internal circulation and external circulation, without affecting the defrost/demist mode in either case; operation of other air distribution modes will switch to a corresponding air distribution mode and quit the defrost/demist mode.

Note: When the defrost/demist function is switched on below a preset temperature, the heated rear window function will automatically operate, the Defrost/Demist button and the heated rear window button indicator lights will illuminate simultaneously.

Heated Rear Window



The heating elements on the inside of the rear window are easily damaged. DO NOT scrape or scratch the inside of the glass. DO NOT stick labels over the heating elements.





Press this button on the control panel to operate the heated rear window function, the indicator in the switch will illuminate. The heated rear window function will automatically turn off after operating for 15 minutes. If the switch is pressed again within 5 minutes, the heated rear window will operate and then remain on for a further 8 minutes. Pressing the switch whilst the heated rear window is on will switch off the function and extinguish the indicator in the switch.

AIR CONDITIONING AND AUDIO SYSTEMS





Note: The heated rear window will only operate when the engine is running.

Note: Heated door mirrors only operate when the heated rear window is activated.

-  Internal circulation
-  External circulation

A/C Display



- 1 Temperature Status
- 2 A/C Cooling Status *
- 3 Blower Speed/Air Distribution Mode Status :
 -  For 'face'
 -  For 'face' and 'feet'
 -  For 'feet'
 -  For 'feet' and 'windscreen'
 -  For 'windscreen'
- 4 Air Recirculation Mode Status :

Entertainment Player

Important Safety Information

- Do not attempt to fit, repair or modify the entertainment system by yourself, because there are high-voltage components in the device, which may cause electric shock. For internal inspection, adjustment or repair, please consult a local MG Authorised Repairer.
 - Do not allow this entertainment and navigation system to come into contact with liquids. If liquids or foreign objects enter into this entertainment and navigation system, please park your vehicle at a safe place, immediately switch off the ignition and contact a local MG Authorised Repairer. Do not use the entertainment and navigation system in this condition because doing so may result in a fire, electric shock, or other failure.
 - If you notice smoke, abnormal noises or odours from the entertainment system, or any other abnormal signs on the screen, switch the ignition off immediately and contact a local MG Authorised Repairer for service.
- Using this entertainment system in this condition may result in permanent damage to the system.
- Operation of the navigation or video functions of the system is prohibited whilst the vehicle is in motion. MG Motor UK accepts no responsibility for any consequences caused by this operation. Please park your vehicle in a safe location select Park/Neutral, and apply the parking brake before making the necessary adjustments or watching "Video".
 - Particularly high or particularly low temperatures will interfere with normal operation. If the vehicle is not used and parked in direct sun or in a cold location for a long time, the car may become particularly hot or cold, in this environment the system may not work properly. Once the temperature inside the car is back to normal, the system will resume normal function. If it does not resume, please contact an MG Authorised Repairer for assistance.
 - Switch off entertainment and navigation system during refuelling.

AIR CONDITIONING AND AUDIO SYSTEMS

- Excessive use of the entertainment and navigation system without the vehicle being driven or engine running can drain the vehicle low voltage battery.
- When using a mobile phone, keep the antenna of the mobile phone away from the screen to prevent the disruption of video signal in the form of spots, colored stripes, etc. on the screen.

Cautions for Using Screen

- To protect the screen against damage, always touch panel keys with your finger. A touch pen may be used for special calibration.
- Please take care to protect the screen against direct sunlight. Extended exposure to direct sunlight will result in screen malfunction due to high temperature.
- When the temperature is beyond the operating temperature range (-30°C to +85°C), please do not use the screen, because the screen may not operate normally and could be damaged.
- Do not use excessive force to drag and drop or press the screen, damage or scratching may occur.

- To remove dust from the screen or clean the screen, power off the system first, then wipe the screen with a dry soft cloth. When wiping the screen, take care not to scratch the surface. Do not use irritative or abrasive chemical cleaners.

Additional Notes

- Some types of external storage devices may not be recognised. This may result in the files not being played or displayed normally.
- Because of file characteristics, file format, recorded application, playback environment, storage conditions and other factors, it may not be possible to play the files normally.

AIR CONDITIONING AND AUDIO SYSTEMS

Basic Operations

Control Panel



1  (HOME) Button

Short press to return to the main interface.

2 Volume Adjusting Button

Main System Interface



1 Radio/Music

Touch to enter the Radio/Music interface.

2 Navigation *

Touch to enter the Navigation interface.



3 HVAC

2

AIR CONDITIONING AND AUDIO SYSTEMS

Touch to enter the AC interface.

4 Others

Touch / or swipe left or right at the bottom of the screen to view the following functions.

- Phone

Touch  to enter the Bluetooth Phone interface.

- Car

Touch  to enter the Vehicle Settings interface.

- Set up

Touch  to enter the Settings interface.

- 360 View *

Touch  to enter the 360 View interface.

- Apple CarPlay *

Touch  to enter the Apple CarPlay interface.

- Android Auto *

Touch  to enter the Android Auto interface.

- Pictures

Touch  to enter the Pictures interface.

- Video

Touch  to enter the Video interface.

- Display Off

Touch  to turn off the display; touch again to wake up the display.

Power On/Off

Power On

If the vehicle power is turned off with the system currently in playback mode, the system will be automatically powered on when the vehicle power is turned on again.

If the vehicle power is turned off with the system in the Off state, short press the Power button on the system control panel to power-on the system after the vehicle power is turned on again.

With the system on, long press the HOME button on the system control panel to enter the Standby mode; keep pressing the button and the system will reboot automatically.

Power Off

Pressing the START/STOP button to the Off position will automatically switch off the Infotainment system.

Standby Mode

With the START/STOP switch on, long press the HOME button to allow the Infotainment system to enter the Standby mode, the operation of the Infotainment system may be suspended.

In Standby mode, all sounds will be muted. To cancel the Standby mode, short press the HOME button.

The following operations can also cancel the Standby mode:

- The system automatically switches to the parking image during parking.
- Turn off the START/STOP switch, the system shuts down directly.

AIR CONDITIONING AND AUDIO SYSTEMS

Control Buttons on Steering Wheel

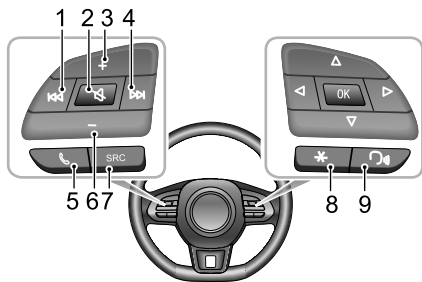

1 ⏮ Button

When playing audio, short press to return to the beginning of the track (except the Bluetooth music mode), short press again to switch to previous track, and long press to rewind (except the Bluetooth music mode). When playing video, short press to switch to previous video, and long press to rewind. When playing radio, short press to automatically search for

the previous station; long press to manually search for the previous station.

2 🚫 Button

Mute/Unmute.

3 🔊 Button

4 ⏭ Button

When playing an audio/video, short press to switch to next audio/video (except the Bluetooth music mode), and long press to fast forward. When playing radio, short press to automatically search for the next station; long press to manually search for the next station.

5 📞 Button

Short press to hang up if in calling/talking state; short press to answer and long press to reject if in incoming call state.

6 🔊 Button

7 SRC Audio Source Switch Button

Switch to the next available media audio source.

8 “*” Shortcut Button

“*” button on the steering wheel can be set as the shortcut key of SmartPhone / Home / Car.

9 Speech Recognition Function Button

Activate/Cancel speech recognition function. This button will only be used after Vehicle-Mobile Phone Interconnection * is enabled.

Note: *Some models do not feature steering wheel control buttons, in these cases all functions described in this chapter that are associated with steering wheel control buttons do not apply.*

Volume Adjustment

The audio volume can be adjusted by the control panel and the buttons on the steering wheel. During the volume adjustment, the system automatically pops up a volume indication window which changes smoothly with the adjustment process.

Note: *The volume buttons on the steering wheel and control panel can only be used for the volume adjustment of audios of media and communication type.*

Note: *The playback volume of Bluetooth music can be adjusted by the device itself and the Infotainment player.*

AIR CONDITIONING AND AUDIO SYSTEMS

Connecting/Disconnecting a USB Storage Device

Inserting a USB Storage Device

Connect a USB device to the USB port for connection.

Removing a USB Storage Device

Check and confirm that there is no data being accessed, then pull out the USB storage device.

Note: If data loss or damage to the storage device occurs for any reason, the data will generally never be recovered. For damages, costs or expenses due to data loss or damage, the manufacturer assumes no responsibility.

Note: Some USB storage devices may be unidentifiable.

Note: The Infotainment system may not achieve its optimum performance when using with some USB storage devices.

Note: Using USB hub or extension cable may not identify USB device.



Bluetooth Phone

Instructions

- Connection to all mobile phones featuring Bluetooth wireless technology is not guaranteed.
 - The mobile phone used must be compatible with the Infotainment system so that all functions of Bluetooth phone of the system can function correctly
 - When using Bluetooth wireless technology, the Infotainment system may not operate all functions on the mobile phone.
 - When transmitting voice and data via Bluetooth technology, the straight-line distance between the Infotainment system and the mobile phone should not exceed 10 metres. However, the actual transmission distance may be shorter than the estimated distance, depending on the usage environment.
 - If Private mode is selected on the mobile phone, hands-free call function will be disabled.
 - When the Infotainment system is turned off, the Bluetooth connection will be disconnected.
- Due to Bluetooth wireless connection, interruption or error occurring in the process of transmission in some extreme cases, and the Infotainment system may be unable to be paired and connected with the mobile phone. At this time, it is recommended to clear the paired devices in the device list on the mobile phone and the Infotainment system, and conduct pairing again.

AIR CONDITIONING AND AUDIO SYSTEMS



Bluetooth Pairing and Connection

If Bluetooth is not enabled, no Bluetooth icon is displayed in the status bar; if Bluetooth is enabled but no device is connected,  is displayed in the status bar; if Bluetooth is enabled and any device is connected,  is displayed in the status bar.

The steps of Bluetooth pairing and connection are as follows:

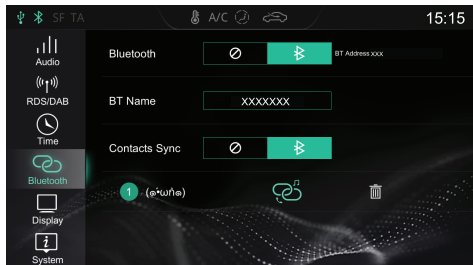
- Touch [Bluetooth] in the Settings interface to enter the Bluetooth connection settings interface, and touch  on the Bluetooth bar to enable the Bluetooth function.



- The system displays the Bluetooth address and the device name.
- Enable the Bluetooth on the mobile phone and search for the Infotainment system for pairing. The mobile phone will receive a Bluetooth Pairing request, after the pairing is completed, a prompt message of Connection Completed will appear. If the pairing fails, please repeat the above steps.
- Touch  to connect to the mobile phone Bluetooth, and touch  to disconnect the Bluetooth. Touch  to remove the mobile phone from the list of paired devices.



AIR CONDITIONING AND AUDIO SYSTEMS

Keypad

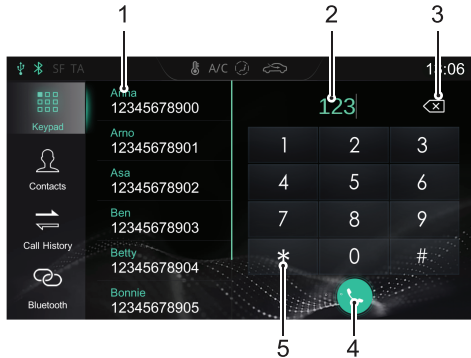
Touch [Keypad] in the Bluetooth Phone interface to enter the Dial Pad interface.



- 1 Address List/Paired Contacts
- 2 Input Box
- 3 Back/Delete Button
- 4 Make a Call

Touch  to make a call; when the Bluetooth phone is connected, touch  to end the call.

- 5 Input Keypad Area
Input figures and symbols.

AIR CONDITIONING AND AUDIO SYSTEMS

Contacts

Touch [Contacts] in the Bluetooth Phone interface to enter the Contacts interface.

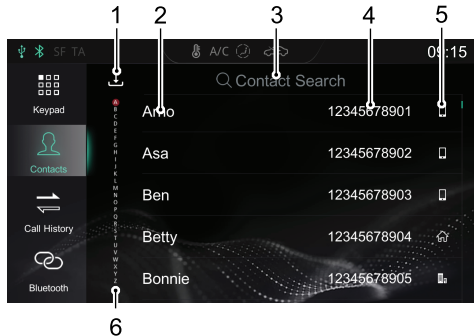

1 Download Contacts

When connected to a mobile phone via Bluetooth the entertainment system default setting will automatically download your contacts. The Auto Contacts

Download function can be disabled or enabled in the Bluetooth Setting Interface.

Touch  in the Contacts interface to download the Contacts manually.



2 Contact Name

3 Search for a Contact

Touch [Contact Search] in the interface, input the initial letter of the name to be searched, after the search is completed, touch the contact to make a call.

4 Phone Number

5 Phone Type

When a contact has multiple phone numbers, touch ,  or  to switch the phone number type and select the phone number to make a call.

6 Quick Contact Search

Touch the letter on the left of the interface or swipe the screen to quickly locate the contact with this letter as the initial letter.

AIR CONDITIONING AND AUDIO SYSTEMS

Note: For some mobile phones, a dialog box asking whether to download Bluetooth phone contacts will pop up before downloading the Bluetooth phone contacts.

Note: Since the system temporarily does not support some commercially available mobile phones, the case of no synchronisation of Bluetooth phone book will occur on non supported phones.

Note: New contacts that are added will not be displayed until the next synchronisation is carried out.



Call History

Touch [Call History] in the Bluetooth Phone interface to enter the Call History interface.

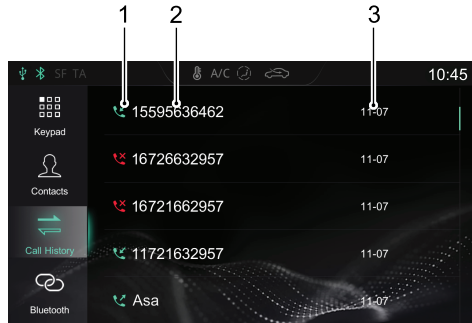
Touch the required call history record in the list to call the contact.



I Call History Type

Dialed Calls: 
Received Calls: 

AIR CONDITIONING AND AUDIO SYSTEMS

Missed Calls: 

- 2 Contact Name/Phone Number
- 3 Talk Time

Call History is arranged by time and date in reverse chronological order.

Bluetooth Connection

Touch [Bluetooth] to enter the Bluetooth Connection interface. Refer to "Bluetooth Pairing and Connection" in this section for details.



Making a Call

You may make a call using the following methods:

- Keypad Input: Refer to "Keypad" in this section for details.
- Call the number in Contacts: Refer to "Contacts" in this section for details.
- Call the number in Call History: Refer to "Call History" in this section for details.
- Make a call directly on the mobile phone.

Ending a Call



You may end a call using the following methods:

- Touch  to hang up.
- Short press  on the steering wheel to hang up.
- Hang up on the mobile phone.



Note: It is illegal to operate a mobile telephone whilst driving. If you wish to make, or take a call using your mobile phone directly, please ensure you pull over in a suitable location and operate the mobile phone where it is safe and legal to do so.

Incoming Call

Answer an Incoming Call

- Touch  to answer an incoming call.
- Short press  button on the steering wheel to answer an incoming call.
- Answer an incoming call on the mobile phone.

Reject an Incoming Call

- Touch  to reject an incoming call.
- Long press  button on the steering wheel to reject an incoming call.
- Reject an incoming call on the mobile phone.

Note: It is illegal to operate a mobile telephone whilst driving. If you wish to make, or take a call using your mobile phone directly, please ensure you pull over in a suitable location and operate the mobile phone where it is safe and legal to do so.

Switch to Private Mode

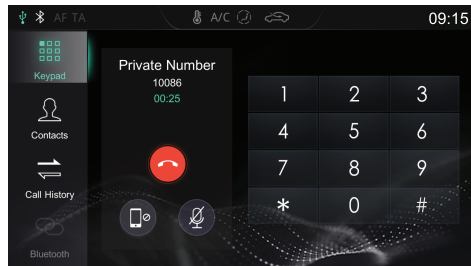

During a call, touch  to enter the Private Mode (Speaker Mode by default).

During a call, touch  to restore the Speaker Mode.

During a call, touch  to switch between Microphone Mute or Enabled function.

In Private Mode, you may continue with the call using the mobile phone; the speakers and microphone of the

AIR CONDITIONING AND AUDIO SYSTEMS

Infotainment system will be muted. But Bluetooth is still connected.

Note: It is illegal to operate a mobile telephone whilst driving. If you wish to make, or take a call using your mobile phone directly, please ensure you pull over in a suitable location and operate the mobile phone where it is safe and legal to do so.

Entertainment

Precautions for Playing a Storage Medium Mode

- The system supports USB drives and Bluetooth storage media.
- If the USB device media is not in use, DO NOT leave the device connected. This may result in connection deterioration.
- Do not remove USB device whilst media is playing. Failure to follow these instructions could result in corrupted data.
- Keep the USB port dry and free from debris. The port will become unusable if it is blocked.

Radio

Touch the Radio/Music area in the main interface, and touch [Radio] again to enter the Radio interface.

To listen to the broadcasting of different bands, touch [DAB] *, [FM] or [AM] in the playback interface to switch between DAB * and radio bands. Pressing the SRC button can also switch between the different radio bands.

DAB *

AIR CONDITIONING AND AUDIO SYSTEMS



- 1 Current Station Name or Frequency
Touch [DAB] *, [FM] or [AM] to switch the band.
- 2 Display of Favorite Stations
- 3 Electronic Program Guide
- 4 DAB Categories List
- 5 Radio information

Touching the button will display radio information, such as text, picture.

- 6 Station List
- 7 List of Favorite Stations
- 8 Add a Station to/Remove a Station from Favorites
- 9 Next Station

Short press to automatically search for the next station; long press to manually search for the next station.

- 10 Previous Station

Short press to automatically search for the previous station; long press to manually search for the previous station.

AIR CONDITIONING AND AUDIO SYSTEMS

FM/AM

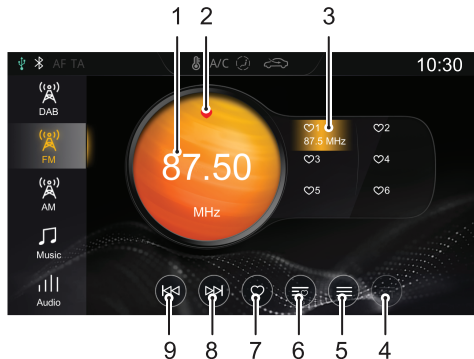

1 Current Station Name or Frequency
Touch [DAB] *, [FM] or [AM] to switch the band.

2 Station Favorites State
❤ indicates that the station has been added to Favorites; 🖤 indicates that the station is not added to Favorites.

3 Display of Favorite Stations

4 Radio Information

Touching the button will display radio information, such as text, picture.

5 Station List

6 List of Favorite Stations

7 Add a Station to/Remove a Station from Favorites

8 Next Station

Short press to automatically search for the next station; long press to manually search for the next station.

9 Previous Station

Short press to automatically search for the previous station; long press to manually search for the previous station.

Touch [Audio] in this interface, and the system skips to the Audio Settings interface.

AIR CONDITIONING AND AUDIO SYSTEMS

2

USB Music

Insert a USB storage device into the USB port, and the system automatically loads the music from the storage device.

Touch the Radio/Music area in the main interface, and touch [USB Music] again to enter the USB Music Playback interface.

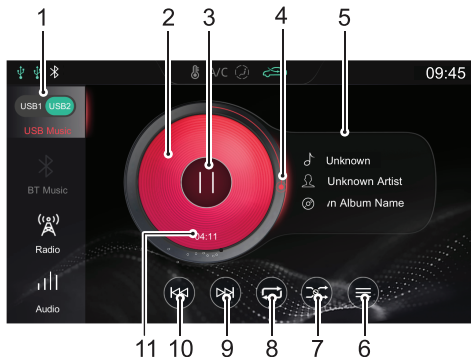

1 USB Drive

When there are two USB drives, you may choose to play music in USB1 or USB2.

2 Album Cover

3 Play/Pause

4 Track Playback Progress Bar

Track playback progress is displayed by the coil, drag the progress bar to skip to certain playing point.

5 Song/Artist/Album Name

6 USB Music List

Touch to enter the corresponding Folder List interface, then touch to select and play the track you prefer.

7 Random Playback Mode

You may switch between Random Playback and Folder Random Playback.

8 Loop Playback Mode

You may switch between Single Loop, Folder Loop and Loop All.

AIR CONDITIONING AND AUDIO SYSTEMS

9 Next Track

Short press to switch to the next track; long press to fast forward.

10 Previous Track

Short press to switch to the previous track; short press during playing to return to the beginning of the track; long press to fast rewind.

11 Current Elapsed Time

Touch [Audio] in this interface, and the system skips to the Audio Settings interface.

Bluetooth Music

Please connect a Bluetooth device first before playing Bluetooth music. Refer to "Bluetooth Pairing and Connection" in "Bluetooth Phone" section for details.

After the Bluetooth device is connected with the system, touch the Radio/Music area in the main interface, and then touch [BT Music] to enter the Bluetooth Music playback interface.



- 1 Play/Pause
- 2 Song/Artist/Album Name
- 3 Next Track
- 4 Previous Track

Touch [Audio] in this interface, and the system skips to the Audio Settings interface.

USB Video

Insert a USB storage device into the USB port, and the system automatically loads the videos from the storage device.

Note: Due to differences in the compression ratio and bit rate of the multimedia formats downloaded from the Internet and other factors, the actual situation of the decoding result shall prevail.

Note: For your driving safety, when the vehicle speed reaches a certain value, the video safety mode will be activated automatically, the video cannot be played at that moment.

Note: The video cannot be played during a call.

Touch [Video] in the main interface to enter the Video Playback interface.

Note: When playing a video, touch the screen to wake up the menu bar mode, and touch it again to exit the menu bar mode.

AIR CONDITIONING AND AUDIO SYSTEMS

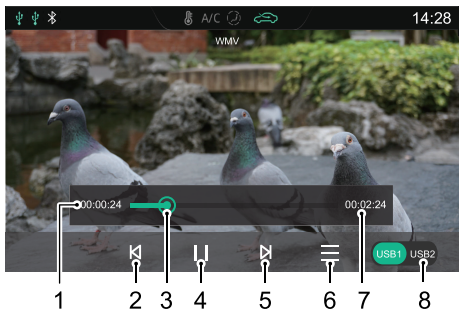

1 Current Elapsed Time

2 Previous Video

Short press to switch to the previous video; long press to fast rewind.

3 Playback Progress Bar

Drag the progress bar to skip to certain playing point.

4 Play/Pause

5 Next Video

Short press to switch to the next video; long press to fast forward.

6 Video List

You may view and play the corresponding video file.

7 Total Video Duration

8 USB Drive

When there are two USB drives, you may choose to play videos in USB1 or USB2.

AIR CONDITIONING AND AUDIO SYSTEMS

Pictures

Insert a USB storage device into the USB port, and the system automatically loads the pictures in the storage device.

Touch [Pictures] in the main interface to enter the picture Playback interface.

Touch a picture file to display it in full screen.

Note: *Whilst viewing a picture file, touch the screen to wake up the menu bar mode, and touch it again to exit the menu bar mode.*

Picture Browsing Interface

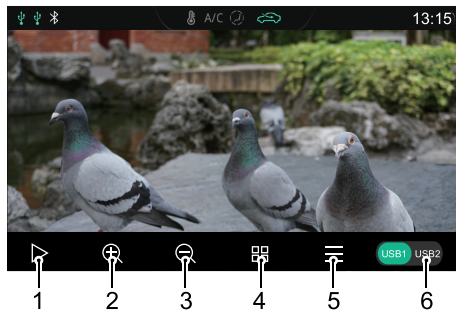

- 1 Slide Show
- 2 Zoom In
- 3 Zoom Out
- 4 Thumbnail
- 5 Pictures List

You may view and play the corresponding picture file.

AIR CONDITIONING AND AUDIO SYSTEMS

6 USB Drive

When there are two USB drives, you may choose to view pictures in USB1 or USB2.

Note: *The system supports the viewing of pictures stored on a USB device. Due to differences in picture resolution, format compression ratio and some other factors not all pictures may be decoded and displayed.*

Note: *Swipe to the left or right on the screen to switch to the next or previous picture.*

Vehicle-Mobile Phone Interconnection *

Only applicable to models that feature Vehicle-Mobile Phone Interconnection.

Apple CarPlay *

Apple CarPlay enables information interaction between the mobile phone and the on-board Infotainment system, including map, music, telephone, short message, podcast, voice recognition .

Connection Method

- 1 Confirm that your mobile phone has the CarPlay function and that it is turned on.
- 2 Connect the mobile phone to the Infotainment system mainframe using a suitable USB cable.
- 3 In the main interface, touch [Apple CarPlay] * area to enter the Apple CarPlay interface.
- 4 After the vehicle and mobile phone are successfully connected, you can operate the iPhone using the Infotainment system screen.

- 5 Press the HOME button on the control panel to return to the main system interface.

Android Auto *

Android Auto enables information interaction between the android mobile phone and the on-board Infotainment system, including map, music, telephone, messages, voice commands.

For the initial application, download and install Android Auto APP to your mobile phone from the market in which it will be operating.

When using , connect the mobile phone to the Infotainment system mainframe using a suitable USB cable. In the main interface, touch [Android Auto] * area to enter the Android Auto interface. Operate according to the interface prompt, then you can use the function once the connection is successful.

A/C

Touch the A/C area in the main interface to enter the A/C System Settings interface. Refer to “Electronic Temperature Control” in this Manual for details.

Vehicle Settings

Touch [Car] in the main interface to enter the Vehicle Settings interface.

Driving Assist *

Touch [Driving Assist] in the Vehicle Settings interface to enter the Driving Assist Settings interface. You can set up the driving assistance system.

Comfort Convenience

Touch [Comfort Convenience] in the Vehicle Settings interface to enter the Comfort Convenience Settings interface where the lights and other functions can be set.

Driving Maintenance

Touch [Driving Maintenance] in the Vehicle Settings interface to enter the Driving Maintenance Settings interface. You can set up some driving control systems.

Factory Setting

Touch [Factory Setting] in the Vehicle Settings interface to enter the Restore Factory Settings interface.

AIR CONDITIONING AND AUDIO SYSTEMS

Touch [Reset] in the Factory Settings interface, and a Reset prompt appears. Please select as needed. Please use with caution.

Settings

Touch [Setup] in the main interface to enter the Settings interface.

Audio Settings

Touch [Audio] in the Settings interface to enter the Sound Settings interface. You can set the volume, EQ and sound stage.

RDS/DAB Settings *

Touch [RDS/DAB] in the Settings interface to enter the RDS/DAB Settings interface. You can set the RDS/DAB related functions.

Time & Date Settings

Touch [Time] in the Settings interface to enter the Time & Date Settings interface to set the date and time.

Bluetooth Settings

Touch [Bluetooth] in the Settings interface to enter the Bluetooth Settings interface to set the Bluetooth

connection function. Refer to “Bluetooth Pairing and Connection” in this section for details.

Display Settings

Touch [Display] in the Settings interface to enter the Display Settings interface. You can set the brightness, backlight mode and units.

System Settings

Touch [System] in the Settings interface to enter the System Settings interface.

- You can view the help file, software version, hardware version and other information of the system.
- Touch [Start] to enter Restore Factory Settings interface, you can select to restore Audio, Radio lists , Other or All to default factory settings as required. After restoring factory settings, the mainframe is reset to its original settings and all data in the Infotainment system will be deleted. Please use with caution.

Seats & Restraints

108 Seats

113 Seat Belts

*124 Airbag Supplementary Restraint
System*

133 Child Restraints

SEATS & RESTRAINTS

Seats

Overview



To avoid personal injuries due to the loss of control, DO NOT adjust the seats while the car is moving.

The vehicle is equipped with 6-direction or 4-direction adjustable front seats and 60/40 split rear seats with foldable backrests.

An ideal position of the seat should make sure your driving position is comfortable, which allows you to hold the steering wheel with your arms and legs slightly bent and control all the equipment. Make sure your driving position is comfortable and enables you to maintain full control of the vehicle. Take care when adjusting the height of front seats - the feet of the rear passenger could become trapped when the seat is lowered.

Do not incline the front-seat backrest excessively. Optimum benefit is obtained from the seat belt with the backrest angle set to approximately 25° from the upright (vertical). The driver and front passenger seats should

be positioned as far rearward as practical. A properly adjusted seat helps reduce the risk of injury from sitting too close to an inflating airbag.

Head Restraints



Adjust the height of the head restraint so that the top of it is in line with the top of the occupant's head. This location may reduce the risk of head and neck injuries in the event of a collision. DO NOT adjust or remove the head restraints while the car is moving.



DO NOT hang anything on any head restraint or head restraint rod.

The head restraint is designed to prevent rearward movement of the head in the event of a collision or emergency braking, thereby reducing the risk of head and neck injuries.

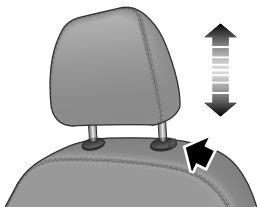

When adjusting a head restraint from low to high position, pull the head restraint directly upward, and gently press it downward after it reaches the desired position to make sure that it is locked in position. To remove the head restraint, press and hold the guide sleeve button (as indicated by the arrow) on the left of the head restraint, then pull the head restraint upward to remove it.

When adjusting a head restraint from high to low position, press the guide sleeve button (as indicated by the arrow) on the left of the head restraint, and press the head restraint downward; release the button after it reaches the desired position, and gently press the head restraint downward to make sure that it is locked in position.

Front Seats

Manual Seat

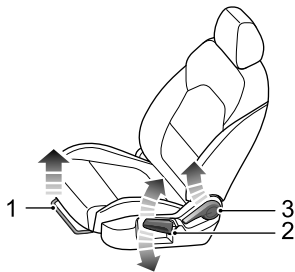

- Forward/Backward Adjustment

Lift the lever (1) under the seat cushion, slide the seat into an appropriate position and release the lever. Make sure that the seat is locked in place.

- Cushion Height Adjustment *

SEATS & RESTRAINTS

Lift the lever (2) repeatedly to raise the seat cushion, and press the lever downward to lower the seat cushion.

- Backrest Adjustment

Lift the lever (3), adjust the backrest until it moves into a satisfiable position, and put down the lever.

Power Seat *

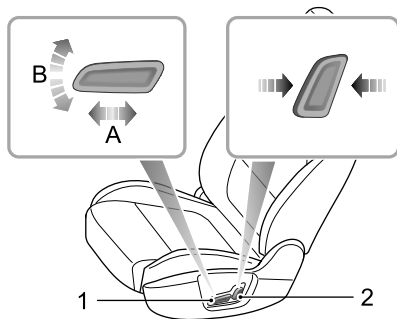

- Forward/Rearward Adjustment

Push the switch (1) forward or backward (A) to move the seat forward/backward.

- Cushion Height Adjustment

Pull the switch (1) upward or push downward (B) to raise or lower the seat cushion.

- Backrest Adjustment

Move the switch (2) forward/backward to adjust the backrest until it reaches the desired angle.

Rear Seats

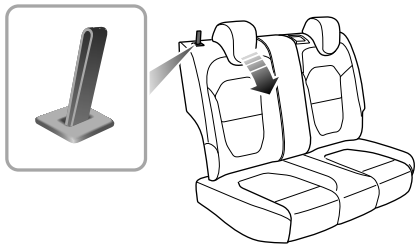

Folding Rear Seats

To increase luggage space, first fully lower (or remove) all the rear seat head restraints, and then pull up the backrest unlock straps on both sides respectively and fold the seat backrests forward.

Note: When the head restraint of the rear seat is not fully lowered or the backrest of the front seat is

inclined backward excessively, the folding of the rear seat is very likely to damage the back of the front seat, small storage compartment or head restraint of the rear seat.

Unfolding and Locking Rear Seat Backrests

When returning the rear seat backrest to the upright position, pull up the backrest unlock straps to release the locked state, push the backrest until it reaches an appropriate position, and the backrest is locked when you hear a click.



Note: When returning the rear seat backrest to the desired position, make sure that the rear seat belt is not trapped.

Front Seat Heating *



If bare skin is in contact with the heated seats for excessive periods of time, it may cause burns.

SEATS & RESTRAINTS

The seat cushion and backrest are provided with heating elements. After starting the engine, pressing  or  will activate the heaters.

When pressing a seat heater switch, the corresponding seat will become warm. Press the switch again to stop the heating function. When the seat heating function is activated, the operating indicator in the switch illuminates. When the cushion temperature reaches approximate 38°C or the backrest to approximate 40°C, the heating function will be deactivated automatically.

IMPORTANT

- Do Not cover the heated seats with blankets, cushions or other insulation type objects or materials.
- If the seat cushion is heated up to 38°C or the seat backrest is heated up to 40°C and continues getting hotter when using seat heating system, please turn off the seat heating and contact MG Authorised Repairer.
- Overuse of the driver's heated seat may cause drowsiness and could affect safety.

Seat Belts



It is important that all seat belts are worn correctly. Always check that all passengers are wearing seat belts. DO NOT carry passengers that are unable to wear correctly positioned seat belts. Wearing seat belts incorrectly may cause serious injury or even death in the event of a collision.



Airbags can not replace seat belts. Airbags can only provide extra support when triggered, and not all traffic accidents will trigger airbags. Whether airbags are triggered or not, seat belts can reduce the risks of serious injury or death in accidents. Therefore, seat belts must be worn properly.



NEVER unfasten a seat belt whilst driving, serious injury or death may occur in the case of an accident or emergency braking.



NEVER fasten the driver seat belt or use a buckle replacement when the driver seat is vacant or when exiting the vehicle. This could cause the engine to restart automatically.



This vehicle is equipped with seat belt warning lamp to remind you to fasten your seat belt.

During driving, seat belts must be fastened, this is because:

- You can never predict if you will be involved in a collision accident and how serious it may be.
- In many cases of collision accidents, passengers with seat belts properly fastened are well-protected, while passengers with seat belts not fastened suffer from serious injury or even death.

Therefore, all passengers must wear seat belts correctly, even during short-distance journeys.

SEATS & RESTRAINTS

Protection Provided by Seat Belts



It is of equal importance for passengers in the rear seat to fasten their seat belts correctly. Otherwise, passengers with seat belts not correctly fastened will be thrown forward in accidents, and will endanger themselves as well as the driver and other passengers.

When the vehicle is in motion, the travelling speed of the occupants is identical to that of the vehicle.

In the event of a 'head on collision' or emergency braking, the vehicle may stop, but the occupants will carry on travelling until they come into contact with a stationary object. This object may be the steering wheel, dashboard, windscreen or front seats.

A correctly fastened seat belt will eliminate this risk of injury. When the seat belt is worn correctly, it will lock automatically in collision accidents or emergency braking to reduce your speed together with the vehicle, so as to prevent the out-of-control movement which may cause serious injury to driver and passengers.



Wearing Seat Belts



Incorrectly worn seat belts could cause injury or death in the event of an accident.



Seat belts are designed for one person, DO NOT share seat belts.



DO NOT wrap a seat belt around when holding a baby or child in your arms.



Remove any heavy coats or clothing when wearing a seat belt, failure to do so can affect protection provided by the seat belt.



Seat belts should not be wrapped around hard or sharp objects such as pens, spectacles or keys.



Seat belts cannot function correctly when the seats are reclined excessively. DO NOT drive when the seats are excessively reclined.

The seat belts fitted to your vehicle are designed for use by normal sized adults. This part of the literature refers to adult use.

All seat belts are 3 point lap-diagonal belts.

In order to maintain effective protection, the passengers must sit in the correct orientation, feet placed on the floor in front of them, with an upright body (no excessive recline) and the seat belt correctly fastened.

SEATS & RESTRAINTS

Fastening Seat Belts

Please follow the instructions below to fasten the seat belts correctly.

- 1 Adjust the seat correctly.
- 2 Hold the metal tab, pull the seat belt out steadily over the shoulder and across your chest. Ensure there is no twist on the belt.

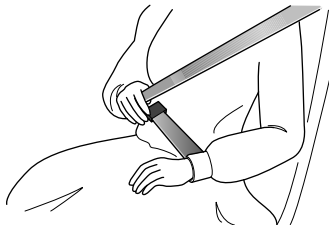

- 3 Insert the metal tab into the buckle until you hear a 'click', this indicates the seat belt is securely locked.

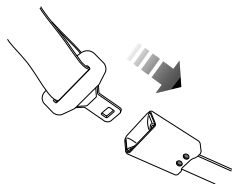

- 4 Remove any slackness in the belt by pulling up on the diagonal section of the belt.
- 5 To release the seat belt, press the red button on the buckle. The seat belt will retract automatically to its original place.

IMPORTANT

- Always ensure the seat belt will not become trapped in the door aperture when closing the door, damage will occur.
- Pulling the seat belt out too quickly may cause it to lock. In this case, allow the seat belt to retract slightly and then pull it across your body slowly.
- If it is difficult to pull the seat belt out, it may be due to twisted webbing. If this is the case, fully extract the seat belt, remove the twist, allow the seat belt to retract slowly.
- When using the rear seat belts please ensure they are fully retracted into the correct position to avoid jamming in the rear seat catches. It is a legal requirement to wear seat belts. Even if the seat belt is twisted it must be worn. Where possible avoid the twisted section contacting the body and seek advice from an MG Authorised Repairer as soon as possible.

Correct Routing of the Seat Belts



Ensure the seat belt is correctly positioned on the body, never cross the neck or abdomen, never pass the seat belt behind the back or under the arms.

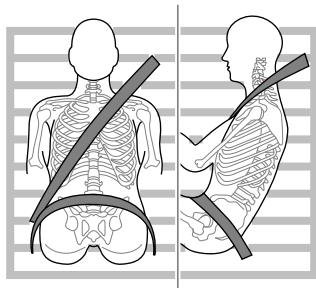

When wearing seat belts, the lap belt section should be positioned as low as possible across your hips, never across the abdomen. In the event of a collision, the lap belt can apply a force on the hips and reduce the possibility of you

SEATS & RESTRAINTS

slipping under the lap belt. If you slip under the lap belt, the belt will apply force on your abdomen, which may cause serious or fatal injuries. The diagonal section of the belt should cross the middle of the shoulder and the chest. In the event of emergency braking or collision, the diagonal section of the belt will be locked.

To ensure that the seat belts always provide maximum protection, ensure the belt is flat, not loose and contacts the body.

Seat Belts Use during Pregnancy

Wearing correctly positioned seat belts will provide protection for both mother and unborn child in the event of a collision or emergency braking.



The diagonal section of the seat belt should pass across the chest as normal, the lap section of the belt should pass below the belly, low and snug on the hip bones. NEVER position the belt on or above the belly.

Please consult your physician for further details.

Seat Belts and Disabilities

It is a legal requirement that all occupants wear seat belts, this include people with disabilities.

Depending upon the disability, consult your physician for further details.

Children and Seat Belts

! *Proper protection measures must be taken for children whilst travelling in the vehicle.*

For safety reasons, children must travel in suitable child restraint devices fixed to the rear seat.

Infants

! *Only recommended child restraints suitable for the age, height and weight of the child should be used.*

! *NEVER carry a child or infant with your arms during driving. When collision accidents occur, the weight of a child will produce such a great force that you can not hold the child. The child will be thrown forward and suffer serious injury or even death.*

The seat belts fitted to your vehicle are designed for adults, they are not suitable for children. In the event of an accident or collision the children are not secure, it could cause death or serious injury.

Infants **MUST** use a suitable child restraint device. Please consult the child seat manufacturers guidelines when selecting the correct seat. Follow the manufacturers instructions on installation. Please refer to "Child Restraints" in this chapter for more details.

Older Children

! *NEVER share a seat belt amongst children. In the event of an accident or collision the children are not secure, it could cause death or serious injury.*

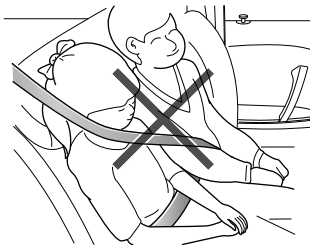

SEATS & RESTRAINTS

As children grow and become older/larger, it will get to the stage when they no longer require child seat restraints, at this point they will require use of the vehicle standard seat belt. Please ensure the seat belt is correctly positioned on the body of the child.

Seat Belt Pre-tensioners



*The seat belt pre-tensioners will only be activated once and then **MUST BE REPLACED**. Failure to replace the pre-tensioners will reduce the efficiency of the vehicle's front restraint system.*



If the pre-tensioners have been activated, the seat belts will still function as restraints, and must be worn in the event that the vehicle remains in a drivable condition. The seat belt pre tensioners should be replaced at the earliest opportunity by an MG Authorised Repairer.

The vehicle is fitted with seat belt pre-tensioners, these are designed to retract the front seat belts and work

in conjunction with the airbags in the event of a severe collision. They are designed to retract the seat belt and 'secure' the occupant in the seat.

The airbag warning light on the instrument pack will alert the driver to any malfunction of the seat belt pretensioners.(see 'Warning Lamps and Indicators' in the 'Instruments and Controls' chapter).

The seat belt pre-tensioners can only be activated once, after activation they must be replaced. This may also involve replacement of other SRS components. Please refer to 'Replacing Airbag System Parts'.

IMPORTANT

- Seat belt pre-tensioners will not be activated by minor impacts.
- The removal or replacement of a pre-tensioner must be carried out by the manufacturer trained, dealer technicians.
- 10 years from the initial date of registration (or installation date of a replacement seat belt pre-tensioner), some components will need to be replaced. The appropriate page of the Service Portfolio must be signed and stamped once the work has been completed.

Seat Belt Checks, Maintenance and Replacement

Seat Belt Checks



Split, worn or frayed seat belts may not function correctly in the event of a collision, if there are any signs of damage, replace the belt immediately.



Always ensure the red release button on the seat belt buckle is pointing upwards to ensure easy release in the event of an emergency.

Please follow the instructions below to regularly check whether the seat belt warning lamp, seat belt, metal tab, buckle, retractor and fixing device are working correctly:

- Insert the seat belt metal tab into the corresponding buckle and pull seat belt webbing close to the buckle quickly to check that the belt clasp locks.
- Hold the metal tab and pull the seat belt forward quickly to check that the seat belt reel locks automatically, preventing the webbing from extending.

SEATS & RESTRAINTS

- Fully extract the seat belt and visibly examine for twists, fraying, splits or worn areas.
- Fully extract the seat belt and allow to return slowly to ensure continual and complete smooth operation.
- Visibly examine the seat belt for missing or broken components.
- Ensure the seat belt warning system is fully functional.

If the seat belt fails any of the above tests or inspections contact an MG Authorised Repairer immediately for repairs.

Seat Belts Maintenance



Seat belt repairs should only be carried out by an MG Authorised Repairer.



Ensure no foreign or sharp objects become lodged in the seat belt mechanisms. DO NOT allow liquids to contaminate the seat belt buckle, this could affect the buckle engagement.

Seat belts should only be cleaned with warm soapy water. Do not use any solvent to clean the seat belt. Do not attempt to bleach or dye the seat belt, it may weaken the seat belt. After cleaning, wipe with a cloth and allow to dry. Do not allow the seat belt to fully retract before it is completely dry. Keep seat belts clean and dry.

If there are contaminants accumulated in the retractor, the retraction of the seat belt will be slow. Please use a clean and dry cloth to remove any contaminants.

Replacing Seat Belts



Collision accidents may damage the seat belt system. The seat belt system may not be able to protect users after damage and may cause serious injury or even death when an accident occurs. After the accident, seat belts should be checked immediately and replaced as necessary.

Seat belts should not require change after minor collisions, however, some other parts of the seat belt system may

require attention. Please consult an MG Authorised Repairer for advice.

SEATS & RESTRAINTS

Airbag Supplementary Restraint System

Overview



*The airbag SRS provides **ADDITIONAL** protection in a severe frontal impact only. It does not replace the need, or requirement to wear a seat belt.*



The airbags together with the seat belts provide optimum protection for adults, but it is not the case for infants. The seat belt and airbag systems in the vehicle are not designed for protecting infants. The protection required by infants should be provided by child restraints.

The Airbag Supplementary Restraint System generally consists of:

- Front Airbags (fitted to the centre of the steering wheel and dashboard above the glove compartment)

- Seat Side Airbags (fitted to the outer side of the seat squab)
- Side Head Impact Protection Airbags (fitted behind the headlining)

Please note that this is model and trim level dependant.

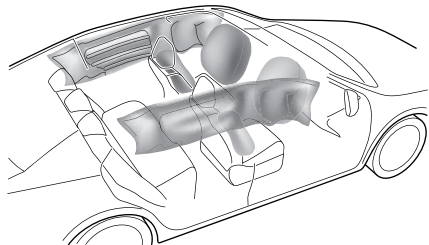

In the corresponding position where airbags are fitted, there is a warning sign stating 'AIRBAG'.

Airbag Warning Light



The airbag warning light is located in the instrument pack. If this lamp does not extinguish or illuminates during driving, it indicates that there is a failure in the SRS or seat belt. Please seek an MG Authorised Repairer at the earliest opportunity. An SRS or seat belt fault may mean the components may not be deployed in the event of an accident.

Airbag Deployment



Front seat passengers should not place feet, knees or any other part of the body in contact with, or in close proximity to a front airbag.



To minimise the risk of accidental injury from inflating airbags, seat belts should be worn correctly at all times. In addition, both driver and front seat passenger should adjust their seat to provide sufficient distance from the front airbags. If side airbags/side head impact protection airbags are fitted, both driver and front seat passenger should be seated to maintain sufficient distance from the upper part of the body to the sides of the vehicle, this will ensure maximum protection when the side airbags/side head impact protection airbags are deployed.

SEATS & RESTRAINTS



When airbags are deployed, children without proper protection may suffer from serious injury or even death. DO NOT carry children in the arms or on the knees during traveling. Children should wear seat belts suitable to age. DO NOT lean out of windows.



An inflating airbag can cause facial abrasions and other injuries if the occupant is too close to the airbag at the time of its deployment.



DO NOT affix or place any objects on, or adjacent to the airbags. This may affect the airbag passage or create projectiles that may cause injury or serious harm in the event of airbag deployment.



After deployment the airbag components become very hot. DO NOT touch any airbag related components, it may cause burns or serious injury.



DO NOT knock or strike the position where airbags or related parts are located, so as to avoid accidental airbag deployment which may cause serious injury or even death.

In the event of a collision, the airbag control unit monitors the rate of deceleration or acceleration induced by the collision, to determine whether the airbags should be deployed. Airbag deployment is virtually instantaneous and occurs with considerable force, accompanied by a loud noise.

Provided the front seat occupants are correctly seated and with seat belts properly worn, the airbags will provide additional protection to the chest and facial areas in the event of the car receiving a severe frontal impact.

Side airbags and side head impact protection airbags are designed to offer additional protection to the side of the body facing the impact, if a severe side collision occurs.

IMPORTANT

- Airbags can not protect lower body parts of passengers.
- Airbags are not designed for rear collision, minor frontal or side impacts, or if the vehicle overturns; nor will it operate as a result of heavy braking.
- Deployment and retraction of the frontal and side airbags takes place very quickly and will not protect against the effects of secondary impacts that may occur.
- When an airbag inflates, a fine powder is released. This is not an indication of a malfunction, however, the powder may cause irritation to the skin and should be thoroughly flushed from the eyes and any cuts or abrasions of the skin.
- After inflation, front and side airbags deflate immediately. This provides a gradual cushioning effect for the occupant and also ensures that the driver's forward vision is not obscured.

Front Airbags



NEVER use a rearward facing child restraint on a seat protected by an ACTIVE AIRBAG in front of it, DEATH or SERIOUS INJURY to the CHILD can occur. Refer to 'Disabling the Passenger Airbag'.



Front seat passengers should not place feet, knees or any other part of the body in contact with, or in close proximity to a front airbag.



In extreme cases driving on very uneven surfaces may cause airbag deployment. Please take extra care when driving on uneven roads.

Airbags are designed to deploy during serious impacts, the following conditions may cause airbag deployment.

- A frontal collision with unmovable or non deformable solid objects at a high speed.
- Conditions that can cause serious chassis damage, such as a collision with kerbstones, road edges, deep ravines or holes.

SEATS & RESTRAINTS

Seat Side Airbags



The manufacture and material of the seat is critical to the correct operation of side airbags. Therefore, please DO NOT fit seat covers which may affect side airbag deployment.

In the event of a serious side impact, the relevant side airbag will deploy (only the affected side).

- The airbag will be deployed in the event that the side of the vehicle is impacted with a solid object or another vehicle.

Side Head Impact Protection Airbags

In the event of a serious side impact, the relevant side curtain airbag will deploy (only the affected side).

- The side curtain airbag will be deployed in the event that the side of the vehicle is impacted with a solid object or another vehicle.

Conditions in Which Airbags Will Not Deploy

The deployment of airbags does not depend on the vehicle speed, but on the object that the vehicle hits, angle of impact and the rate at which the car changes speed as a result of a collision. When the impact force of collision is absorbed or dispersed to vehicle body, airbags may not deploy; however, airbags may sometimes deploy according to impact condition. Therefore, the deployment of airbags shall not be judged based on the severity of vehicle damage.

Front Airbags

Under certain conditions the front airbags may not be deployed. Some examples are listed below:

- The impact point is not central to the front of the vehicle.
- The impact is not of sufficient force (the impact is with an object that is not solid, such as a lamp post or central barriers).
- The impact area is high (collision with the tailgate of a truck).
- Impacts to the rear or side of the vehicle.

- The vehicle rolling over.

Seat Side Airbags and Side Head Impact Protection Airbags

Under certain conditions the seat side and side head airbags may not be deployed. Some examples are listed below:

- Side impacts at certain angles.
- Light side impacts such as a motorcycle.
- Impacts that are not central to the side of the vehicle, either too far toward the engine compartment or the loadspace.
- The vehicle rolling over.
- The angled impact is not of sufficient force (the impact is with an object that is not solid, such as a lamp post or central barriers).
- The impact is not of sufficient force (with another vehicle, stationary or moving).
- The impact is from the rear of the vehicle.

Disabling the Passenger Airbag



The Passenger Airbag should only be disabled when a rear facing child seat is fitted to the front passenger seat.



When an adult is seated in the front passenger seat, ensure that the airbag is switched on.

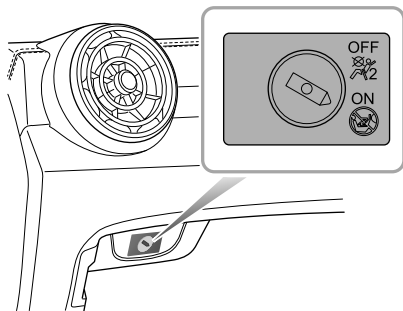

SEATS & RESTRAINTS

The passenger airbag disable switch is located inside of the glovebox, To disable the passenger airbag, insert the key and turn the switch to OFF position.

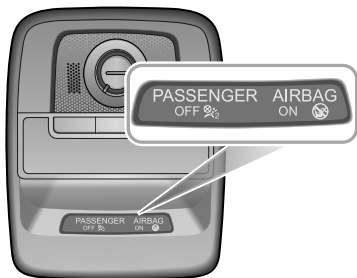

The passenger airbag status light is located in the roof mounted interior lamp assembly. The shape of the lamp assembly varies according to the configuration of the vehicle.

When the switch is turned to the OFF position, the OFF indicator light (located in the PAB display panel in the lamp assembly) illuminates, this indicates that the passenger airbag is disabled.

When the switch is turned to the ON position, the ON indicator light (located in the PAB display panel in the lamp assembly) illuminates, this indicates that the passenger airbag is enabled.

Service and Replacement of Airbags

Service Information



DO NOT install or modify the airbag. Any changes to the vehicle structure or airbag system wiring harness are strictly prohibited.



Changes to vehicle structure is prohibited. This may affect the normal operation of the SRS.



DO NOT allow these areas to be flooded with liquid and DO NOT use petrol, detergent, furniture cream or polishes.



If water contaminates or enters the SRS it may cause damage and affect deployment. In this case contact an MG Authorised Repairer immediately.

To prevent damage to the airbag SRS, the following areas should be cleaned sparingly with a damp cloth and upholstery cleaner ONLY:

- Steering wheel centre pad.
- Area of dashboard containing the passenger airbag.
- Area of roof lining and front pillar finishers which enclose the side head impact protection modules.

If the airbag warning lamp fails to illuminate, stays on, or if there is damage to the front or side of the vehicle, or the airbag covers show signs of damage, contact an MG Authorised Repairer immediately.

IMPORTANT

- The removal or replacement of an airbag module should be carried out by an MG Authorised Repairer.
- After 10 years from the initial date of registration (or installation date of a replacement airbag), some components will need to be replaced by an MG Authorised Repairer. The appropriate page of the Service Portfolio must be signed and stamped once the work has been completed.

SEATS & RESTRAINTS

Replacing Aribag System Parts



Even if the airbag does not deploy, collisions may cause damage to SRS in the vehicle. Airbags may not function properly after damage, and can not protect you and other passengers when a second collision occurs, which may cause serious injury or even death. To ensure that SRS can function properly after collision, please go to an MG Authorised Repairer to check airbags and repair as necessary.

Airbags are designed for using once only. Once the airbag is deployed, you must replace SRS parts.

Please go to an MG Authorised Repairer for replacement.

Disposal of Airbags

When your vehicle is sold, ensure that the new owner knows the vehicle is equipped with airbags, and is aware of the replacement date of SRS.

If the vehicle is scrapped, the undeployed airbags may have potential risks, therefore, before the disposal, they must be deployed safely in a certain environment by a professional from an MG Authorised Repairer.

Child Restraints

Important Safety Instructions about Using Child Restraints

It is recommended that children below the age of 12 years old should be seated on the rear seat of the vehicle, in a child restraint system appropriate to the children's weight and size. Infants less than 2 years old should be restrained in an infant child restraint system.

It is recommended that a child restraint system that complies with UN ECE-R44 or ECE-R129 standard are fitted in this vehicle. Check markings on the child restraint system.

There are a number of child restraint systems available of different type and specification. For optimum protection, it is recommended that you choose restraint systems appropriate to the child's age and weight.

It is important to comply with installation instructions supplied by the child restraint manufacturer and that child restraint system is properly secured to the vehicle. Failure to follow these instructions may cause death or serious injury to the child in an event of a sudden stop or accident.

- All occupants, including children must wear seat belts or use an appropriate child restraint.
- It is recommended that children under 12 years of age or less than 1.5 metres tall should use the appropriate child restraint fitted to the rear seat.
- Only one child can be carried in any one restraint.
- Do not put the child on the lap or in arms when sitting in any seat.
- Always adjust the seat back rest to a central position and ensure it is locked in position when installing a child seat or restraint.
- If installing a rear facing child restraint to the rear seat, the corresponding front seat should be adjusted forward; if installing a forward facing child restraint to the rear seat, you may need to adjust the height of the headrest to the lowest; if installing a forward facing child restraint to the front seat, you may need to remove its headrest.
- Never let your child stand or kneel on the seat during driving.
- Always ensure the child is seated correctly in the child restraint.

SEATS & RESTRAINTS

- The ways of using seat belts have a great influence on the maximum protection offered by the seat belt, you must comply with the child restraint manufacturer's instructions on proper use of seat belts. If seat belts are not properly fastened, a minor traffic accident may also lead to injury.
- Child restraints that are not fitted correctly may move and injure other occupants in the event of an accident or emergency braking. Therefore, even if there is no infant or child in the child restraint, it also should be fitted properly and securely in the vehicle.

Warnings and Instructions on Use of Child Restraint on Front Passenger Seat



When the front passenger airbag is active, never install a rear facing child restraint on the front passenger seat, severe injury or even death can occur.



In cases where there is a need to install a rear facing child restraint on the front passenger seat, use the key to deactivate the front passenger airbag function, or severe injury or even death can occur.



Once the child restraint is removed from the front passenger seat, use the key to reactivate the front passenger airbag.



When installing a child restraint on the front passenger seat, move the front passenger seat as far rearward as possible.



Use one child restraint per child.

Please study the safety warning label on the sun visor. Where possible always install child restraints on the rear seat. If it is necessary to install a child restraint on the front seat please observe the warnings above.

Children's Safety and Side Airbags



Children should not be allowed in areas where airbags may be deployed, there is a risk of serious injury.



Only recommended child restraints suitable for the age, height and weight of the child should be used.



DO NOT place any items in areas where airbags may be deployed, there is a risk of serious injury.

In the event of a side collision, the side airbags can provide better protection for the passenger. However, when the airbag is triggered a very strong expansion force is generated, if the passenger's seating position is not correct,

the airbags or items in the side airbag deployment area may cause injury.

When the correct child restraint is used to secure the child properly in the rear seat and the child's seating position is correct, there is enough space between the child and the side airbag deployment region for the airbag to deploy without any hindrance, and thus provide the best protection.

SEATS & RESTRAINTS

Child Restraints Groups

Secured Using 3 Point lap Diagonal Belts



Please DO NOT put the rear facing child restraint in the front passenger seat, this may cause serious injury or even death.

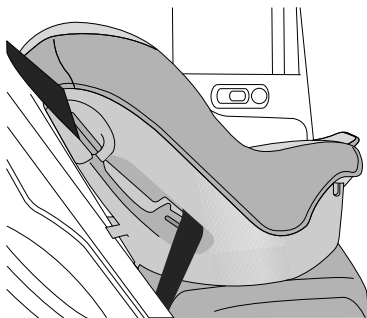

It is recommended that children should always be seated in the rear of the vehicle in a child restraint or restraint system, and fixed with 3 point, lap diagonal seat belts.

ISOFIX Child Restraint Systems



The ISOFIX anchorages in the rear seat are designed for use with ISOFIX systems only.



Child restraint anchorages are designed to withstand only those loads imposed by correctly fitted child restraints. Under no circumstances are they to be used for adult seat belts, harnesses, or for attaching other items or equipment to the vehicle.

Note: *When installing and using any child restraint system, always follow the manufacturer's instructions.*

Note: *The rear seats fitted to this vehicle are provided with the ISOFIX interface (as indicated by the arrow in the following image), these are designed to connect to an ISOFIX child seat.*

SEATS & RESTRAINTS

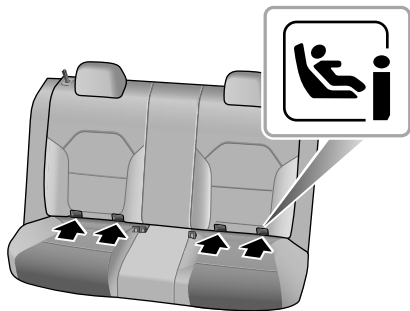

- Fasten vehicle-approved ISOFIX child restraint systems to the mounting brackets.
- When using ISOFIX mounting brackets for seat mounting, universally approved child restraint systems for ISOFIX may be used.

Note: *When using seat mounting, universally approved child restraint systems, Top-tether must be used.*

Note: *Please refer to the child restraint system manufacturer's instructions for details.*

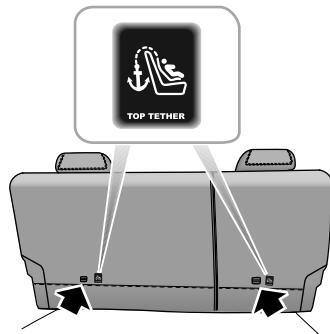

- To fasten the Top tether strap of the child restraint system, route the tether strap under the head restraint and attach to the anchorage hook being careful not to twist the strap. If not using ISOFIX lower anchorages, using the seatbelt, complete the installation in line with the child restraint manufacturer's instructions.

SEATS & RESTRAINTS

- After installation apply suitable force to ensure the restraint is securely fastened.

Approved Child Restraint Positions

It is recommended that a child restraint system that complies with UN ECE-R44 or ECE-R129 standard are fitted in this vehicle. Check markings on the child restraint system.

Approved Child Restraint Positions (for non ISOFIX Child Restraints)

Mass Group	Seating Positions				
	Front Passenger			Rear Outboard	Rear Middle
	Without Front Passenger Airbag OFF Switch	With Front Passenger Airbag OFF Switch			
		Airbag ON	Airbag OFF		
0 group (less than 10 kg)	X	X	X	U	X
0+ group (less than 13 kg)	X	X	X	U	X
I group (9 ~ 18 kg)	X	X	U	U	X
II group (15 ~ 25 kg)	U	U	U	U	X
III group (22 ~ 36 kg)	U	U	U	U	X
Note: Description of letters in the table: U = Suitable for universal child restraint systems approved for this mass group; X = Seat position not suitable for child restraint systems in this mass group.					

SEATS & RESTRAINTS

Approved Child Restraint Positions (for ISOFIX Child Restraints)

Seating Position		Mass group categories			
		0 group	0+ group	I group	
		Rear facing		Forward facing	Rear facing
		Up to 29 lbs(13 kg)		20–40 lbs(9 ~ 18 kg)	
Front Passenger Seat	Size Class	Not ISOFIX equipped			
	Seat Type				
Rear Outboard Seat ISOFIX	Size Class	C,D,E ¹	A,B, BI ¹	C,D ¹	
	Seat Type	IL ²	IL ² ,IUF ³	IL ²	
Rear Centre Seat	Size Class	Not ISOFIX equipped			
	Seat Type				

Note: IL Suitable for particular ISOFIX child restraints systems of the semi-universal category. Please consult child restraints systems suppliers' vehicle recommendation lists;

IUF Suitable for ISOFIX forward facing child restraints systems of universal category approved for use in this mass group and ISOFIX size class;

¹. The ISOFIX size class for both universal and semi-universal child seat systems is defined by the capital letters grade A ~ G. These identification letters are displayed on the ISOFIX child seat;

². At time of publishing the recommended Group 0+ ISOFIX baby safety seat is the Britax Romer Baby Safe. Consult an MG Authorised Repairer for the latest details relating to our recommended child seats;

³. At time of publishing the recommended Group I ISOFIX child seat is the Britax Romer Duo. Consult an MG Authorised Repairer for the latest details relating to our recommended child seats.

Note: At time of publishing the recommended Group II-III ISOFIX child seat is the KidFix XP. Consult an MG Authorised Repairer for the latest details relating to our recommended child seats.

Table of I- Size child seats

The table gives a recommendation for which I- Size child seats suit which locations, and for what size of child.

The child seat must be approved in accordance with UN Reg R129.

Type of child seat	Front passenger seat	Rear outboard seats	Rear centre seat
I- Size child restraint systems	X	I-U	X

Note: I-U Suitable for use with forward and rear facing I- Size child restraint systems.

X Not suitable for use with I- Size restraint systems.

SEATS & RESTRAINTS

Group 0/0+ Child Restraint



When the front passenger airbag is active, never place a rear facing child restraint on the front passenger seat, severe injury or even death can occur.

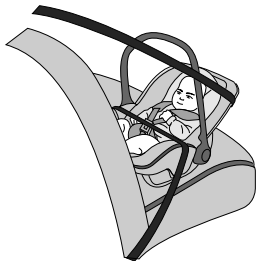

Child restraints that can be adjusted to lying position are most suitable for infants who are lighter than 10 kg (normally for those younger than 9 months) or those who are lighter than 13 kg (normally for those younger than 24 months).

Group I Child Restraint



When the front passenger airbag is active, never place a rear facing child restraint on the front passenger seat, severe injury or even death can occur.

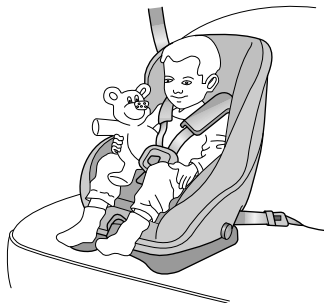

Backward/forward child restraints are most suitable for infants whose weight is 9 ~ 18 kg (normally for those older than 9 months and younger than 4 years old).

Group II Child Restraint



The diagonal section of the seat belt should pass across the shoulder and upper body, away from the neck. The lap section of the belt should pass across the hips, away from the abdomen.



The combination of child restraint and 3 point lap diagonal seat belt is most suitable for children whose weight is 15 ~ 25 kg (normally for those older than 3 years old and younger than 7 years old).

Group III Child Restraint



The diagonal section of the seat belt should pass across the shoulder and upper body, away from the neck. The lap section of the belt should pass across the hips, away from the abdomen.



The combination of child booster seat and vehicle 3 point lap diagonal seat belt is most suitable for children whose weight is 22 ~ 36 kg and whose height is below 1.5 m (normally for those about 7 years old or those older than 7 years old).

Starting & Driving

- 146 Keys
- 151 Child Proof Locks
- 152 Alarm System
- 159 Starting and Stopping Engine
- 167 Economical and Environmental Driving
- 170 Catalytic Converter and Particulate Filter
- 172 Fuel System
- 174 Automatic Transmission *
- 181 Manual Transmission *
- 184 Brake System
- 197 Automated Stop/Start — Intelligent Fuel Saving System
- 202 Stability Control System (SCS) and Traction Control System (TCS)
- 204 Cruise Control System
- 207 Active Speed Limit (ASL) System
- 210 Parking Aid System *
- 214 Rear Driver Assistance System *
- 220 Tyre Pressure Monitoring System (TPMS)
- 222 Load Carrying

STARTING & DRIVING

Keys

Overview



Keep the spare key in a safe place - not in the vehicle!



It is recommended that spare keys are not kept on the same key ring, since this may cause interference and prevent correct key recognition and therefore prevent the engine from starting.



The key contains delicate electronic components and must be protected from impact and water damage, high temperature and humidity, direct sunlight and the effects of solvents, waxes and abrasive cleaners.

Different key kits are provided according to vehicle configurations. One kit includes two smart keys; and the other kit includes two remote keys. They can open all locks.

The keys supplied to you have been programmed for the security system on your vehicle. Any key that is not programmed to your vehicle can not start the engine.

The key only works within a certain range. Its operating range is sometimes influenced by the key battery condition, physical and geographical factors. For safety consideration, after you lock your vehicle by the key, please recheck if the vehicle is locked.

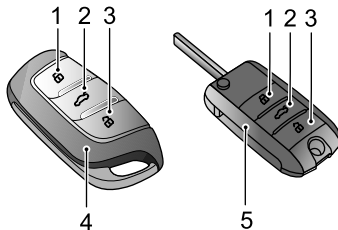

- 1 Lock button
- 2 Tailgate release button
- 3 Unlock button

- 4 Smart key
- 5 Remote key

If your key is lost/stolen or broken, a replacement can be obtained from an MG Authorised Repairer. The lost/stolen key can be deactivated. If the lost key is found, an MG Authorised Repairer can reactivate it.

Note: Any key made independently outside of MG Authorised Repairer Network may not start the engine, and may affect the safety of your car. To obtain a suitable key replacement, it is recommended that you can consult MG Authorised Repairer.

Note: The new key cannot be offered to you immediately because it requires programming to the vehicle by the MG Authorised Repairer.

Note: When operating your vehicle with the smart key, avoid placing it near the devices with strong radio interference (such as notebook computers and other electronic products), the normal function of the key may be affected.

Replacing the Battery

Please use the picture guide to replace the key battery if any of the following conditions occur:

- The key locking/unlocking function range is reduced;
- The engine immobilisation warning lamp on the instrument pack flashes (Refer to "Warning Lights and Indicators" in "Instruments and Controls" section).

Smart Key *

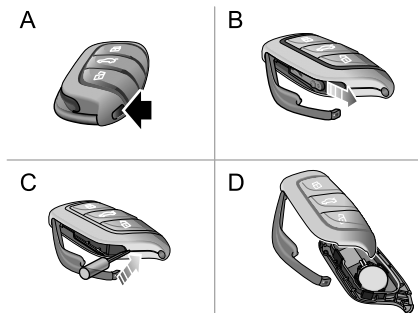

STARTING & DRIVING

- 1 Press the button (A) on the smart key to eject the decorative trim.
- 2 Remove the backup mechanical key (B) in the arrowed direction.
- 3 Using a suitable flat bladed tool, insert the tool into the side of the key (C), carefully prise off the battery cover and separate the upper and lower casings (D).
- 4 Remove the battery from the slot.
- 5 Put the new battery in the slot, and make sure it is in full contact with the slot.

Note: Make sure that the polarity of battery is correct ('+' side facing down).

Note: It is recommended to use a CR2032 battery.

- 6 Refit the cover and press tightly, ensuring the gap around the cover is even.
- 7 Refit the mechanical key, and close the decorative trim.
- 8 Start the engine to resynchronise the key with the vehicle.

Remote key *

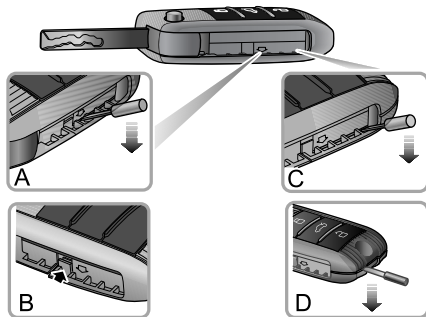

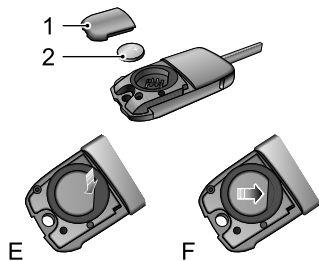

- 1 Unfold the remote key.
- 2 With a flat-bladed tool, insert it below the arrow mark at the side of the key (A), and pry up the battery cover carefully until the lock pins are separated (B).
- 3 Then insert the flat-bladed tool into the illustrated position (C), and apply pressure in the direction indicated by the arrow until the tail of the key makes a gap.

- 4 Continue to use the flat-bladed tool inserting it into the end of the key/battery cover (D), slightly pry the battery cover until the two bayonets at the end of battery cover are released.
- 5 Carefully prise off the battery cover (1).
- 6 Press the front part of button battery using slight force (E) to remove the battery (2).
- 7 Position the new battery, ensuring that correct polarity is maintained (“+” side facing up), slide it forward (F) ensuring it is fully inserted into the slot.

Note: Make sure the polarity is correct (positive side upward).

Note: It is recommended to use the CR2032 replacement battery.

- 8 Refit the cover and press tightly, check the gap around the cover is even.
- 9 Insert the remote key into ignition switch to resynchronise it.

STARTING & DRIVING

IMPORTANT

- Use of an incorrect or inappropriate battery may damage the key. The new replacement's rated voltage, sizes and specifications must be the same as the old one.
- Incorrect fitting of the battery may damage the key.
- Disposal of the used battery must be strictly in accordance with relevant environmental protection acts.

Child Proof Locks



NEVER leave children unsupervised in the vehicle.

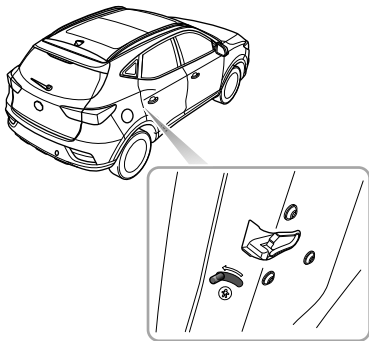

- Open the rear door at corresponding side, move the child proof lock lever to the lock position in the direction of the arrow to engage the child proof lock;
- Move the lever to the unlock position in the reverse direction of the arrow to disable the child proof lock.

With the child proof lock locked, the rear door at the corresponding side cannot be opened from inside the car, but can be opened from outside the car.

Steps for enabling or disabling the child proof locks are as follows:

STARTING & DRIVING

Alarm System

Your car is fitted with an anti-theft alarm and engine immobilisation system. To ensure maximum safety and operation convenience, we strongly recommend you to carefully read this chapter to fully understand the activation and deactivation of anti-theft systems.

Engine Immobilisation

Engine Immobilisation is designed to safeguard the vehicle from theft. Engine Immobilisation can only be deactivated to start the engine by using the matched key.

Engine Immobilisation (Key Start) *

When the matched key is inserted into the START/STOP Switch and the car is started, engine immobilisation is deactivated automatically. When the key is removed from the START/STOP Switch, the vehicle will automatically enable engine immobilisation. When the START/STOP Switch is in the ON position, if the engine immobiliser cannot identify the key inserted into the START/STOP Switch, the engine immobilisation warning lamp in the instrument pack illuminates. If the engine still can not

be started by using the spare key, please contact an MG Authorised Repairer.

Engine Immobilisation (Keyless Start) *

Press the START/STOP Switch on the instrument panel, once a valid key is detected in the vehicle, the immobilisation system will be deactivated automatically.

If the message centre displays 'Smart Key Not Detected' or 'Put Key Into Back-up Position' or the anti-theft immobiliser system warning lamp illuminates, please put the smart key at the bottom of the centre console cup holder or storage compartment (refer to 'Alternative Starting Procedure' in 'Starting and Stopping Engine' section), or try to use the spare key. If the car can still not be started, please contact an MG Authorised Repairer.

Anti-theft System

Locking and Unlocking

When the vehicle is locked, the indicator lamps flash three times; when it is unlocked, the indicator lamps flash once.

Operation of Door Lock System (Key)

Key Locking

- Using the remote key to lock: press the lock button on the key to lock the car after closing the doors, bonnet and tailgate.
- Using the mechanical key to lock: partially operate the door release handle, using a suitable flat blade tool, insert the tool into the underside of the trim and carefully remove the door lock trim cover, insert the key into the driver door lock and turn counterclockwise to lock the car.

Key Unlocking

- Using the remote key to unlock: press the unlock button on the key to unlock the car.
- Using the mechanical key to unlock: partially operate the door release handle, using a suitable flat blade

tool, insert the tool into the underside of the trim and carefully remove the driver door lock trim cover, insert the key into the driver door lock and turn clockwise to unlock the car.

Note: *If the START/STOP Switch is not placed in ACC or ON/RUNNING position within 15 seconds after the vehicle is unlocked with the mechanical key, the engine immobilisation alarm will be triggered.*

Note: *If no panels are opened within 30 seconds after the vehicle is unlocked by using the remote key, all doors will automatically re-lock.*

Operation of Door Lock System (Keyless) *

The keyless entry system can lock and unlock the doors and tailgate as long as you carry the smart key and approach to the car.

IMPORTANT

The smart key must be within 1.5 metres of the vehicle for the keyless system to operate correctly.

STARTING & DRIVING

Keyless Locking

After switching the START/STOP Switch to OFF position and exiting the car, press the door handle button once before moving away from the car to lock all doors and tailgate (no need to press the lock button on the key). Note, this will also arm the alarm and immobilise the vehicle.

Keyless Unlocking

Press the button on the front door handle once to unlock the car, then pull the door handle to open the door.

Note: *When the vehicle is locked, if you are within the smart key range and operate the door handle button, but carry out no further action, after 30 seconds the vehicle will automatically re-lock itself to remain secure.*

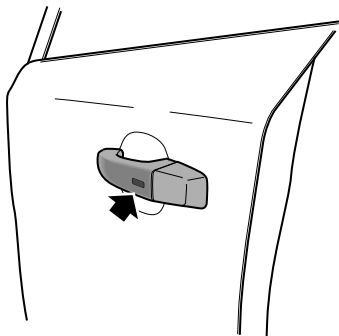

IMPORTANT

After the door is locked by using the key, press the button on the door handle to unlock the car. If the car cannot be unlocked or locked normally, seek an MG Authorised Repairer.

Mislock

If the driver's door is not fully closed when the smart key lock button is pressed, or the START/STOP Switch has not been switched OFF, the vehicle horn will sound once, indicating a mislock. In this case, none of the doors will lock, the alarm system will not be armed.

If the driver's door is closed, the passenger door, bonnet and tailgate are not fully closed, the horn sounds once to indicate mislock when the car undergoes locking operation. However, the 'partial arming' attributes of the security system will enable as much of the system to be armed as possible (all fully closed doors, bonnet or tailgate apertures will be protected, but an open door will not!). The alarm indicator will flash. As soon as the open aperture is closed, the system will automatically revert to an armed state

Inadvertent Locking of Keys in Vehicle *

If the vehicle is locked using the mechanical key blade or handset whilst a smart key/s remain inside, the following actions will occur:

- One smart key locked in the vehicle - The immobilisation release function of the smart key locked

in the vehicle is suspended, the lock and unlock function of the smart key is retained. The engine cannot be started. To reinstate the immobiliser release function of the smart key locked in the vehicle the second smart key should be used to unlock the vehicle. The function will automatically be reinstated.

- Both smart keys locked in vehicle - The immobilisation release function of both smart keys locked in the vehicle is suspended, the lock and unlock function of the smart keys is retained. The engine cannot be started. The reinstatement of key functions can only be carried out using the approved diagnostic tool. Consult an MG Authorised Repairer immediately.

Anti-theft Alarm Sounder

If the anti-theft alarm has been triggered, the car horn will sound continuously. Press the UNLOCK button on the key, the anti-theft alarm will be deactivated.

STARTING & DRIVING

Interior Lock and Unlock Switch

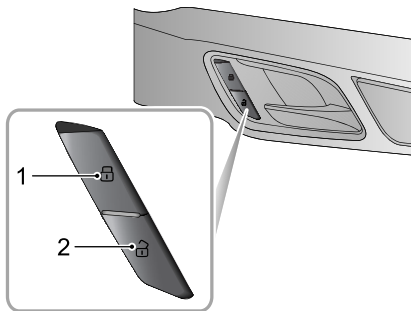

- 1 Lock Switch
- 2 Unlock Switch

When the anti-theft alarm system is not in operation, press the lock switch (1) to lock all doors; press the unlock switch (2) to unlock all doors.

Note: *If the anti-theft alarm system is switched on, pressing the lock/unlock button will not lock/unlock the doors but will trigger the alarm system.*

If the doors, bonnet and tailgate are closed, press the interior lock switch. The yellow indicator on the interior lock switch illuminates.

If a mislock is caused by non-driver door, tailgate or bonnet, press the interior lock switch. The yellow indicator on the interior lock switch illuminates.

Interior Door Handles

When the anti-theft alarm system is not in operation, use the interior door handle to open the door:

- 1 Pull the interior door handle once to unlock the door.
- 2 Pull the interior door handle again to open the door.

Speed Lock

All the doors will be locked automatically when the road speed exceeds 10 mph (15 km/h).

Automatic Unlock

When the START/STOP Switch is switched to the OFF position, all the doors will be unlocked automatically.

Tailgate



If the tailgate can not be closed due to the type of cargo loaded, be sure to close all windows during driving, select the face distribution mode of the air condition, and set the blower to maximum speed, so as to decrease exhaust fumes entering the vehicle.

Tailgate Open Mode

The tailgate can be opened by using the following 2 methods:

- When the vehicle is unlocked or the matched key appears within 1m range around the tailgate, directly open the tailgate by turning over the emblem on the tailgate (Figure A).
- When START/STOP Switch in the OFF position, press the release button on the remote key (Figure B) for more than 2 seconds to open the tailgate.

STARTING & DRIVING

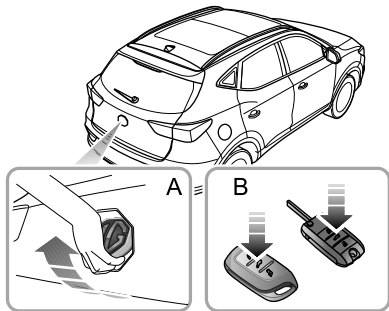

Emergency Tailgate Opening

The emergency tailgate release access is located in the centre of the tailgate trim.

Fold down the rear seat to gain access, remove the blanking plug, and rotate the emergency open knob counterclockwise to open the tailgate from inside.

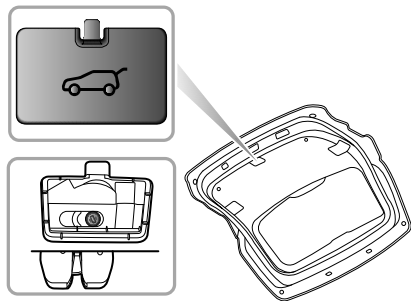

Starting and Stopping Engine

Ignition Switch (Key Start) *



When the vehicle is in motion, DO NOT switch off the ignition or remove the key, otherwise the steering wheel may be locked, making it impossible to turn the vehicle.



When the vehicle is in motion, DO NOT touch the key to avoid engine flameout!

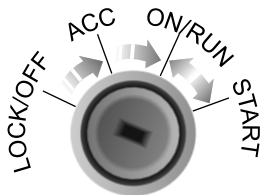

The ignition switch is located on the right side of the steering column. Function of each position is as follows:

Position LOCK/OFF

- The key can be inserted or removed.
- After the engine is stopped and the key is removed, turn the steering wheel to one side to lock the steering wheel.

Position ACC

- The engine is not started and the key cannot be removed.
- Some individual electrical equipment and accessories can be operated, such as power windows.

Position ON/RUNNING

- All electrical equipment is operational.
- After the vehicle is started, the engine runs.

Position START

- Engine will run after starting.
- Release the key immediately after the engine is started, the ignition switch will return to position ON/RUNNING automatically.

STARTING & DRIVING

- When the engine is starting, some electrical equipment will be isolated during cranking.

Note: *The key can only be turned from ACC position to LOCK/OFF position when the shift lever is in P (parking) position.*

Note: *When the ignition switch is in the OFF position, if the driver side door is opened, an audible warning sounds to indicate that the key has not been removed.*

Note: *When the steering wheel is locked and the key cannot be turned from the OFF position to the ACC position, please turn the steering wheel slightly whilst turning the key to unlock the steering wheel.*

START/STOP Switch (Keyless Start)*



The keyless START/STOP Switch is located in the fascia to the left of the steering column, it is a push button style switch.

Note: *To operate the system, the remote key must be in the car. To remove the gear lever from the Park position, the START/STOP Switch must be in ON/RUNNING position, and the brake pedal must be depressed.*

The operational status displays are as follows:

Indicator Off (OFF)

- The engine is shut off in this position.

Yellow Light (ACC)

- Some electrical equipment can be operated, such as power windows.
- Pressing the START/STOP Switch without the footbrake being applied whilst the engine is OFF will place the system in the ACC state, this will illuminate the yellow indicator in the switch button.

Green Light (ON/RUNNING)

- All electrical equipment is operational.
- Drive and start the vehicle.
- Whilst in the ACC state, pressing the START/STOP Switch without the footbrake being applied will place the system in the ON state, the green indicator will illuminate.

Note: *After turning the START/STOP Switch to the OFF position and opening the door, if the key is still left in the vehicle, the audible warning will sound when*

closing the door, to remind you that the key is still in the vehicle.

If your car is subject to strong radio signals the keyless entry and start systems may suffer from interference and not function correctly. Please see the 'Alternative Starting Procedure'.

STARTING & DRIVING

Starting the Engine (Key Start) *



Never start or leave the engine running in an unventilated building. Exhaust gases are poisonous and contain carbon monoxide, which can cause unconsciousness and may even be fatal.



Catalytic converters and particulate filters can be damaged if the wrong fuel is used, or if an engine misfire occurs. Before starting the engine, please read carefully the contents in the "Catalytic converter and Particulate Filter" section.

Operation of Starting the Engine

- 1 Switch off all unnecessary electrical equipment (including the air conditioning);
- 2 Apply the parking brake (refer to "Brake System" of this section);
- 3 For auto transmission vehicles, ensure the shift lever is in P or N position;

Note: When the shift lever is in any other position, the engine cannot be started.

- 4 For manual transmission vehicle, ensure neutral is selected and the clutch pedal is fully pressed;
- 5 Insert the key, rotate it to position START and release the key immediately after the engine is started.

Note: After the engine starts, if the key is not released immediately, the starter will continue to work, which will not only discharge the battery, but also damage the starter and starter motor, catalytic converter and particulate filter.

Starting the Engine (Keyless Start) *

Starting the Engine:

- 1 Switch off all unnecessary electrical equipment (including the air conditioning);
- 2 Apply the parking brake (refer to "Brake System" of this section);
- 3 For auto transmission vehicles, Ensure P or N is selected and press the brake pedal .
- 4 For manual transmission vehicles, ensure neutral is selected and the clutch pedal is fully pressed.
- 5 Press the START/STOP Switch (do not hold the button in, release immediately).

Alternative Starting Procedure (Auto Transmission)

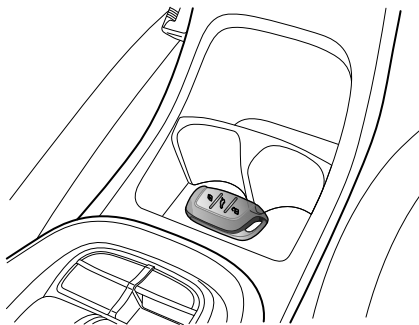

If the car is located in an area where there are strong radio signals causing interference or the smart key battery condition is low, please use the following steps to attempt to start the car:

- 1 For vehicles with cup holder, remove the cup holder .

STARTING & DRIVING

- 2 Place the smart key centrally in the centre console cup holder cubby box with the buttons facing upward - as shown in the illustration.
- 3 Ensure P or N is selected, press the brake pedal and then press START/STOP Switch to start the vehicle.

If the immobiliser cannot be released after the car has left the area of strong radio interference or had the smart key battery replaced please consult an MG Authorised Repairer.

Alternative Starting Procedure (Manual Transmission)

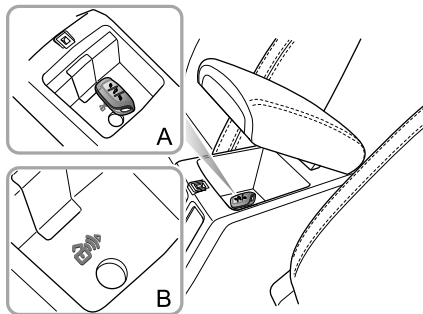

If the car is located in an area where there are strong radio signals causing interference or the smart key battery condition is low, please use the following steps to attempt to start the car:

- 1 Place the smart key centrally in the centre console cup holder cubby box with the buttons facing upward - as shown in the illustration.
- 2 Press the clutch pedal and press START/STOP Switch to start the vehicle.

If the immobiliser cannot be released after the car has left the area of strong radio interference or had the smart key battery replaced please consult an MG Authorised Repairer.

Precautions for Starting the Engine

Idle speed will decrease after engine warm-up. Do not increase engine speed immediately after engine starts. Progressively operate the engine and transmission so that oil can preheat and lubricate all operating components.

DO NOT press the accelerator pedal while starting and DO NOT operate the starter for more than 15 seconds at a time.

In temperatures of -10°C and below, engine cranking times will increase. It is essential that all unnecessary electrical equipment is switched off while cranking.

IMPORTANT

- If the vehicle will not enter a ON/RUNNING state, please check for any warning indicators or messages displayed in the instrument pack message centre. In extremely low temperatures please allow 5 minutes between starting attempts, if after 3 attempts the vehicle will not start please consult an MG Authorised Repairer or breakdown service.
- DO NOT leave the ignition switch in the ACC, ON/RUNNING or START positions for any length of time when the engine is not running, otherwise it may lead to battery discharge due to the use of electrical equipments.
- The vehicle is fitted with engine immobilisation system. Any independently made key cannot start the engine.
- Your car is controlled by electronic control systems. When starting the engine, please make sure there are no electronic devices that can create electromagnetic interference near the vehicle. This may cause issues with the electronic control systems on the vehicle.

STARTING & DRIVING

Stopping the Engine

Stop the engine as follows:

- 1 After bringing the car to a stop, continue to apply the footbrake until the parking brake is applied;
- 2 Apply parking brake;
- 3 For vehicles with automatic transmission, ensure that the shift lever is in P position.
- 4 For vehicles with manual transmission, ensure that the shift lever is in neutral position.
- 5 For vehicles with key start , turn the key from ON/RUNNING position to LOCK/OFF position, the engine will be shut down and the key can be removed.
- 6 For vehicles with keyless start , press START/STOP Switch to shut down the engine.

Note: For vehicles with keyless start , when the engine needs to be stopped in emergency, please press START/STOP Switch and hold for more than 4 seconds to stop the engine.

Note: After strenuous towing or driving at high speed (particularly in hot weather), it is suggested to allow the engine to idle for a few minutes before switching off, which enables the cooling system to work continuously to lower the engine temperature.

Economical and Environmental Driving

Running-in

The engine, transmission, brakes and tyres need time to 'bed-in' and adjust to the demands of everyday motoring. During the first 900 miles, please heed the following advice so as to enhance the long-term operation performance:

- Do not allow the engine to exceed 3000 rpm in any gear or the vehicle speed to exceed 72 MPH.
- Do not operate at full throttle or allow the engine to labour in any gear.
- Do not drive at a constant speed (either high speed or low speed).
- Avoid heavy braking where possible.

After 900 miles, engine speeds can be gradually increased.

Environment Protection

Your vehicle has been designed with the latest technology in order to minimize the environmental impact of exhaust emissions.

Economic Driving and Maintenance

The following are some suggestions on saving fuel and extending the life of the vehicles.

- Maintain the correct tyre pressures; insufficient air pressure will accelerate tyre wear and waste fuel.
- Do not carry unnecessary weight. Heavy loads will increase the engine load resulting in higher fuel consumption.
- Avoid engine idling for extended periods.
- Maintain slow and smooth acceleration and avoid harsh acceleration; change to a higher gear as soon as possible.
- Avoid labouring the engine or over running. Choose appropriate gears according to the road conditions.
- Avoid continuous acceleration or deceleration. A stop-go driving style will consume more fuel.
- Avoid unnecessary stopping and braking, maintain steady speed and attempt to anticipate traffic lights.

Note: *Keep an appropriate distance from other vehicles to avoid emergency braking and reduce brake pad wear.*

STARTING & DRIVING

- Avoid traffic congestion and jam areas as much as possible.
- Anticipating obstructions and slowing down well in advance, avoids the need for unnecessary acceleration and harsh braking. A smooth driving style not only reduces fuel consumption, but can reduce the emission of noxious gases.
- Do not ride the brake pedal, this can cause premature wear, overheating and increased fuel consumption.
- Maintain an appropriate speed on the highway. Higher speeds use more fuel. Appropriate speeds can save fuel.
- Maintain the correct wheel alignment. Avoid collision with the kerb and reduce speed on uneven road surfaces. Out of specification wheel alignment will not only lead to excessive tyre wear, but also increases the engine load and fuel consumption.
- Avoid driving on mud or beaches. This will prevent corrosion of the vehicle underside.
- Maintain the vehicle in accordance with MG recommendations. Dirty air filters, oil etc., will reduce the engine's performance and raise fuel consumption.

Note: To extend the life of all components and reduce operating costs, regular MG Approved maintenance is needed.

- Do not stop the engine straight after high speed or long ascents or towing a trailer. Allow the engine to idle for 20 to 100 seconds depending upon driving loads and conditions. Avoid hard acceleration on a cold engine.

Driving in Special Environment

Driving in Rain or Snow



Emergency braking, accelerating and steering on slippery roads will reduce the vehicle's handling performance and grip.

- When raining the windows may fog, reducing visibility (Use the Air-conditioning demist function).
- Grip will be reduced when it rains, so please reduce speed drive carefully.
- Reduce speed when it rains.
- Avoid aquaplaning (the effect of a film of water between the tyres and the road) affecting steering and braking performance.

Driving through Water

Avoid driving through floods after heavy rain, this may lead to serious damage to the vehicle.

STARTING & DRIVING

Catalytic Converter and Particulate Filter



The temperatures of exhaust systems that contain particulate filters and catalytic converters can be extremely high, DO NOT park on ground where combustible materials such as dry grass or leaves could come into contact with the exhaust system - in dry weather a fire could result.

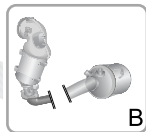
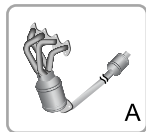
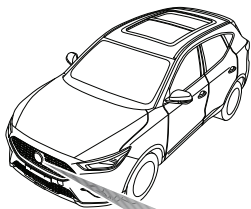

The exhaust system incorporates a catalytic converter and particulate filter (model dependant), these process possible harmful exhaust emissions from the engine into more environmentally friendly gases. Exhaust system layouts differ between engine derivatives. The 1.5L exhaust features (A). The 1.0T exhaust features (B).

Catalytic converters and particulate filters are easily damaged through improper use, especially if the wrong fuel or oil to the incorrect specification is used.

Fuel

- Use only fuel recommended for your car.
- Never allow the car to run out of fuel – this could cause serious damage to the catalytic converter and particulate filter.

Engine Oils

- It is recommended that only oils that meet the manufacturers specification are used. Use of oils that do not meet the manufacturers specifications can damage the particulate filter, for example low SAPS oils can affect particulate filter ash capacity.

Starting

- Do not continue to operate the starter after a few failed attempts; seek an MG Authorised Repairer.
- Do not operate the starter if an engine misfire is suspected and do not attempt to clear a misfire by pressing the accelerator pedal.
- Do not attempt to push or tow start the car.

Regeneration

- On occasion the particulate filter may require regeneration. Your vehicle will automatically carry out this procedure when certain conditions are met. During this process you may experience slight power loss and uneven engine running.

Driving

Please pay attention to the following conditions:

- Do not overload or excessively 'rev' of engine.
- Do not stop the engine when the car is in motion with a gear selected.
- Seek an MG Authorised Repairer if you think your car's oil consumption is abnormal.

- If a misfire is suspected, or the car lacks power while driving, provided the engine has reached its normal operating temperature, it may be driven SLOWLY (at risk of catalyst and particulate filter damage) to an MG Authorised Repairer.
- Do not drive on terrain likely to subject the underside of the car to heavy impacts.

Note: *Any engine misfire, loss of engine performance or engine run-on, could seriously damage the catalytic converter and particulate filter. Regular maintenance must be carried out in accordance with the schedule specified in the 'Service Portfolio'. Any modifications to engine without being authorised is prohibited.*

STARTING & DRIVING

Fuel System

Fuel Requirements



Use only the recommended fuel which meets national standard! Serious damage to the catalytic converter, a reduction in engine power/torque and increase in fuel consumption will occur if the wrong fuel is used.

Please use the fuel which is recommended and certified by the manufacturer. See 'Major Parameters of Engine' in 'Technical Data'.

If a lower grade of fuel is used, an engine knocking noise may occur, please use the recommended or above grade fuel as soon as possible. If the engine knocking noise is still noticeable after using the recommended or above grade fuel, please contact MG Authorised Repairer immediately.

Safety Precautions in a Fuel Filling Station



Vehicle fuel gases are highly flammable and, in confined spaces, are also extremely explosive.

Always take care when refueling:

- Switch off the engine.
- Do not smoke or use a naked flame.
- Do not use a mobile phone.
- Avoid spilling fuel.
- Do not overfill the tank.

Fuel Filler

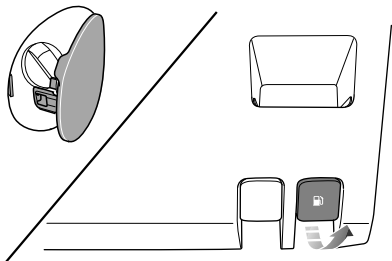

Fuel Filler Flap

The fuel filler flap is located on the rear right-hand wing. Pull the fuel filler flap release handle under the driver side instrument pack to open the flap.

Fuel Filler Cap

Unscrew the filler cap anti-clockwise and allow any pressure inside the tank to escape, before removing the cap.

After refueling, tighten the filler cap clockwise until you hear one "click" sound.

Refueling

Do not fully fill the tank if the vehicle is to be parked in direct sunlight, or high ambient temperature - expansion of the fuel could cause spillage. The fuel filler tube is designed to accept a narrow, long filler nozzle. There is a cover at the filler neck, by inserting the filler nozzle thoroughly before fuel filling, the cover can be fully opened.

Start the engine after fuel filling. After refueling, if the engine runs unevenly, switch off and seek an MG Authorised Repairer before attempting to restart the engine.

STARTING & DRIVING

Automatic Transmission *

Instructions

The following information is very important, please read carefully before use.

- Before starting the engine, place the gear lever in P or N position, ensure the foot brake is pressed and the parking brake is applied.
- After the engine has started, ensure the foot brake and parking brake are applied, shift the lever to the required gear.
- Release the parking brake and hold the foot brake until you are ready to manoeuvre the vehicle. Once the foot brake is released, on flat road, the vehicle will automatically start off at a slow speed without application of the accelerator.
- Do not move the gear shift lever into P or R from D whilst driving, this will cause severe transmission damage or cause an accident.
- To remove the gear lever from the Park position, the vehicle must have battery power and the START/STOP Switch must be in ON/RUNNING position.

Gear Shift

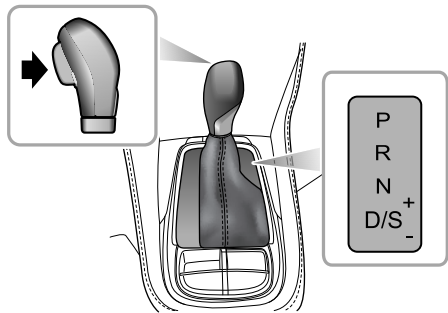

The automatic transmission is a 6 speed transmission.

Note: *The highlighted letters or numbers in the information centre indicate the selected gear or mode.*

A sprung loaded lock button, located in the gear lever, is used to prevent mistakenly selecting P (Park) or R (Reverse) whilst the gear selector is in other positions.

Shift Lever Operation



Unless necessary, it is not recommended to press lock button during gear shifting.

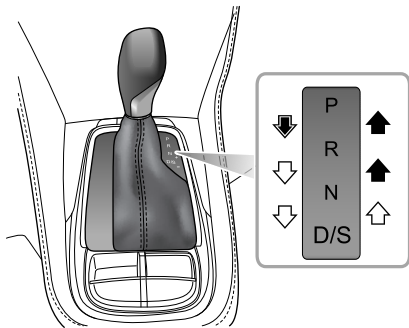

During the gear shift, operate the shift lever according to the instructions indicated by the following arrows:



Free gear shift.



Press and hold the lock button to shift the gear.



Press and hold the lock button and apply the brake pedal to shift gear.

Shift Lever Position



The shift lever must be placed in P position when parked.



DO NOT move the gear shift lever into P or R from D whilst driving, this will cause severe transmission damage or cause an accident.

- P Park

When the shift lever is in this position, the transmission will be mechanically locked. Use this gear only when the vehicle is stationary and the parking brake is applied.

STARTING & DRIVING

Note: *When the vehicle is parking on a hill, press the brake pedal and apply the parking brake first and then select P gear.*

- R Reverse

Select this gear only when the vehicle is stationary and the engine is running at idle speed.

- N Neutral

Select this gear when the vehicle is stationary and the engine is running at idle speed for a short time (for example, waiting for traffic lights).

- D Drive

This is used for normal driving and will allow automatic selection of 6 gears depending on vehicle speed and accelerator position.

- S Sport Mode

Select this mode when a more sporty acceleration performance is required.

- + Upshift

Whilst in Manual mode, upshift the transmission to the next available high gear.

- - Downshift

Whilst in Manual mode, downshift the transmission to the next available low gear.

Gearshift Speed

Selecting D will allow the transmission controller to carry out gearshifts taking in consideration of a number of factors including engine speed, vehicle speed and accelerator position. Light accelerator pedal application will result in a gear-change at low speeds, larger pedal applications will result in gear-changes at higher speeds.

Kick-down



The drive wheels may skid when kick-down is activated on road surfaces with low adhesion, this may lead to the vehicle sliding out of control.

With D gear selected, pressing the accelerator pedal all the way down in one motion (also known as Kick-down) will provide better acceleration performance during overtaking. Under certain conditions, it will allow the

transmission to shift to a lower gear immediately, and provide fast acceleration. Once the accelerator pedal is released, it will resume to a suitable normal high gear (based on the vehicle speed and the position of the accelerator pedal).

Driving on the Hill



In cases where a short stop on a hill is required, such as a traffic jam, DO NOT momentarily apply the accelerator to prevent “roll back”. This could cause the transmission to overheat and result in damage.

Hill Start

In cases of a hill start, where the vehicle has been stationary for some time, the foot brake has been released and the electronic parking brake applied, the starting assist function of the electronic parking brake (EPB) can be used to prevent the vehicle from rolling backwards. With the seat belt safely fastened, press the foot brake, apply the electronic parking brake system, and select the desired gear (D/R/S), then release the foot brake; press the accelerator pedal to engage vehicle drive, the electronic parking brake system will automatically be deactivated.

STARTING & DRIVING

Models fitted with Hill Hold Control can use this function to assist hill starts. For details on hill hold control system, please refer to "Foot Brake" of "Brake System" section.

Note: *The assistance of these functions cannot defy the laws of physics. DO NOT drive the vehicle beyond its physical limitations, loss of control will still occur.*

Downhill Driving



Repeated application of the footbrake may result in the brakes becoming overheated. This will cause a reduction in braking performance and may even result in brake failure.

If driving down a hill for long distances, it is advised to move the gear shift lever to the right and select the Manual mode. This allows manual gear selection. Use a lower gear selection to aid the slowing of the vehicle and thus avoiding over-use of the brakes. If a threshold is reached, the vehicle will automatically shift up, in these cases use of the brakes to slow the vehicle is necessary, at the same time re-select the lower gear.

Control Mode

Economy Mode

Selecting D automatically places the vehicle in the Economy Mode. The information centre display will show "D". Economy Mode provides optimum fuel consumption and emissions.

Sport Mode

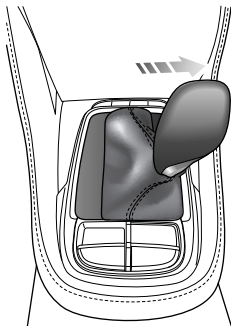

Once D is selected, move the shift lever to the right to select S and enable the Sport Mode (the gear displayed in information centre changes to "S"). Under Sport Mode, the transmission upshifts later, so as to make full use of the power reserves of the engine .

When better acceleration is required, please select the Sport Mode, but please note that the fuel consumption will be increased when driving in Sport Mode.

To exit Sport Mode, move the shift lever to the left back into D position.

Cruise Control Mode

With the cruise control function enabled, the transmission will switch to the relevant gear for the vehicle speed automatically, thereby avoiding frequent gear shifts when the system needs to maintain a constant speed.

Manual Mode

With Sport Mode selected, move the shift lever toward "+" or "-", this will enable Manual Mode. The gear displayed in the information centre will indicate current gear with a single number (1 ~ 6).

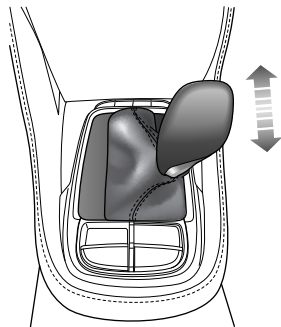

Move the shift lever toward "+" direction to upshift to next available high gear, move toward "-" direction to downshift to next available low gear.

With Manual Mode selected, if the driver makes an unreasonable gear selection, requests an upshift during low engine speeds, or requests a downshift during high engine speeds, the transmission will not respond and will remain in the current gear. If the vehicle is driven and the engine speed falls below a preset threshold in certain

STARTING & DRIVING

gears, the transmission will automatically shift down to the next gear to avoid engine stalling; when the vehicle accelerates, if the engine speed exceeds a preset limit, the transmission will automatically shift up to the next gear to protect the engine.

With Manual mode selected, the information centre will provide gear shift indications, the UP or DOWN arrow is displayed at the right side of the gear position number, indicating to the driver to upshift or downshift when the conditions permit.

Note: *The gear shift operation should be carried out on the premise of ensuring your own safety and observing the traffic regulations.*

To return to Sport Mode or any other modes, shift the lever across to the left and select D.

Automatic Transmission Failure

If the automatic transmission develops a problem, the engine emission malfunction indicator lamp in the instrument pack will illuminate or the message centre will display “EP”.

Some “failure modes” will cause the transmission to enter “Limp Mode”, during this time only certain gear positions can be selected and/or work, for example, R gear may not be selectable. If a serious functional failure occurs the vehicle cannot be driven, please consult an MG Authorised Repairer immediately.

Note: *When the vehicle is in ‘Limp Mode’, manual gear selection functions are disabled and therefore not available.*

Manual Transmission *

5-speed Manual Transmission *

Shift lever

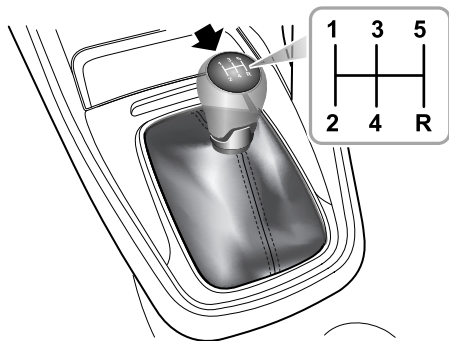

The manual transmission is a 5-speed transmission with 6 gears, which are: 1st, 2nd, 3rd, 4th, 5th, R (Reverse) respectively.

Precautions while driving:

- 1 When selecting R gear, you must ensure that the vehicle is completely stationary, wait for a moment and then fully depress the clutch pedal to complete the gear shift.

Please wait for 2 ~ 3 seconds before shifting to R gear, otherwise the damage to the reverse gear may occur.

Please wait for 1 ~ 3 seconds before shifting to forward gear, otherwise the excessive wear to the synchronizer may occur.

- 2 Do not rest your hand on the shift lever while driving - pressure from your hand may cause premature wear to the gear shift mechanism.
- 3 Do not rest your foot on the clutch pedal when driving - excessive wear to the clutch may occur.
- 4 Do not hold the car stationary on a hill by slipping the clutch. This will wear out the clutch.

STARTING & DRIVING

Gear Shift Indications

When the vehicle is in motion and the clutch pedal fully released, the information centre will display the currently selected gear (1-5). An Up/Down arrow is displayed to the right of the number indicating to the driver to either upshift or downshift when driving conditions permit.

Note: *The gear shift operation should be carried out on the premise of ensuring your own safety and observing the traffic regulations.*

6-speed Manual Transmission *

Shift lever

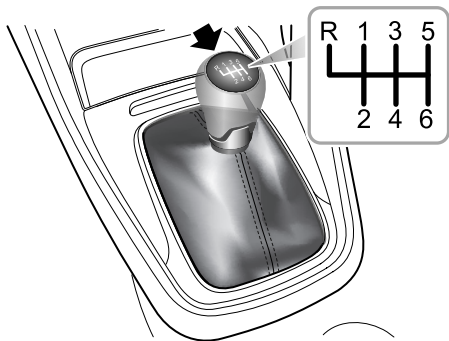

The manual transmission is a 6-speed transmission with 7 gears, which are: 1st, 2nd, 3rd, 4th, 5th, 6th, R (Reverse) respectively.

Precautions while driving:

- 1 When selecting Reverse gear, you must ensure that the vehicle is completely in stationery, wait for a moment and then fully press the clutch pedal, from the N position, press the lever down and push it leftward, then push it forward into the R position, slowly release the clutch pedal to complete the gear shift.

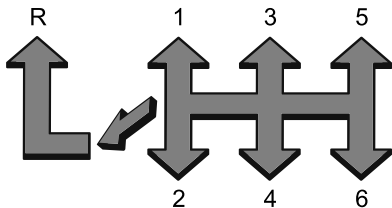

Please wait for 2 ~ 3 seconds before shifting to R gear, otherwise the damage to the reverse gear may occur.

Please wait for 1 ~ 3 seconds before shifting to forward gear, otherwise the excessive wear to the synchronizer may occur.

- 2 Do not rest your hand on the shift lever while driving - pressure from your hand may cause premature wear to the gear shift mechanism.
- 3 Do not rest your foot on the clutch pedal when driving - excessive wear to the clutch may occur.
- 4 Do not hold the car stationary on a hill by slipping the clutch. This will wear out the clutch.

Gear Shift Indications

When the vehicle is in motion and the clutch pedal fully released, the information centre will display the currently selected gear (1-6). An Up/Down arrow is displayed to the right of the number indicating to the driver to either upshift or downshift when driving conditions permit.

Note: *The gear shift operation should be carried out on the premise of ensuring your own safety and observing the traffic regulations.*

STARTING & DRIVING

Brake System

Foot Brake

For added safety, the hydraulic braking system operates through dual circuits. If one circuit should fail, the other will continue to function, but greater pedal pressure will be needed, and increased brake pedal travel, and longer stopping distances will be experienced. In the event of a brake failure where only one circuit is operational, the car should be brought to a halt as soon as traffic conditions safely allow. **DO NOT** continue driving - seek an MG Authorised Repairer.

Servo Assistance

The braking system is servo assisted, always be aware of the followings during the operation:

- The servo assistance functions with the engine running only. Never allow the car to coast with the engine turned off.
- Always take particular care when being towed with four wheels on the ground and the engine turned off. If the engine should stop for any reason while driving, bring

the car to a halt as quickly as traffic conditions safely allow, and do not pump the brake pedal as the braking system will lose any remaining servo assistance.

- Once the engine has stopped it will lose any remaining servo assistance, use suitable force to apply the brake pedal to stop the car safely in the current traffic conditions. Contact an MG Authorised Repairer.
- Efficiency of the brake servo booster can be affected by numerous conditions, such as engine speed loss. These conditions could result in extra force required to operate the brake pedal to stop the car.

Wet Conditions

Driving through water or heavy rain may adversely affect braking efficiency. The SCS (Stability Control System) includes a Brake Disc Wiping function which is activated when the windscreen wipers are used. However, always keep a safe distance from other vehicles and intermittently apply the brake pedal in conditions where the wipers are not used.

Electronic Brake Force Distribution (EBD)

Your car is equipped with Electronic Brake Force Distribution, which, in order to maintain braking efficiency, distributes braking forces between front and rear wheels, under all load conditions.

EBD integrates a monitoring system. The monitoring system is linked to the brake system malfunction indicator lamp on the instrument pack. Refer to "Warning Lights and Indicators" in "Instruments and Controls" section.

If the indicator lamp illuminates while driving, or remains illuminated after the START/STOP Switch is switched ON/RUNNING, it indicates there is a failure with the braking system, and EBD may be inoperative. In such a case, stop the car as soon as safety permits and seek an MG Authorised Repairer immediately. DO NOT drive the car with the braking system malfunction indicator lamp illuminated.

Electronic Brake Assistance (EBA)

Your car is equipped with Electronic Brake Assist, which reacts to the speed at which the brake pedal is applied. If,

in an emergency situation the brakes are applied faster than the limits set within the system, then full ABS application is applied to bring the car to a stop in the shortest possible distance.

Hill Hold Control (HHC)



HHC has limitations when subject to adverse conditions such as wet or icy surfaces and steep slopes.



HHC is not a substitute for parking brake application when carrying out a hill start. DO NOT exit the vehicle with only HHC applied, it may lead to a serious accident when HHC releases.



The car may roll if 'pull-away' is not achieved immediately after releasing the brake pedal.



Always ensure the brake pedal is pressed or electronic parking brake applied until drive is taken up.

STARTING & DRIVING



Firm application of the brake pedal when stopping is required by HHC to generate sufficient brake pressure to maintain hold.

HHC assists the driver by 'holding' the vehicle during hill starts.

The following conditions must be fulfilled to activate HHC:

- The driver's door is closed and the driver seat belt is fastened.
- The vehicle is stopped on a slope for more than 2 seconds.
- SCS is active and fault free.
- EPB is released and fault free.
- Clutch pedal is pressed (MT), or in D/R gear (AT).
- START/STOP Switch is switched ON/RUNNING.
- Sufficient brake pedal application force has been applied.

If the driver releases the brake pedal on a hill, HHC will maintain brake pressure for 1 - 2 seconds, after this period the vehicle may roll backwards.

Note: HHC cannot overcome physical limitations. DO NOT solely rely on HHC.

Note: HHC is available in both forward and backward directions when pulling away on uphill slopes.

Hill Descent Control (HDC)



The HDC system is only an auxiliary function. It has limitations when subject to adverse conditions such as wet or icy surfaces and steep slopes. The HDC system cannot overcome the laws of physics, always ensure that the vehicle is driven down steep slopes at low speeds.



Even when the HDC system is switched on, the driver must always pay close attention to the driving state of the vehicle, and take active control when necessary. In certain cases, HDC may be suspended or switched off temporarily.



During some driving conditions on downhill surfaces (e.g. driving down a slope at high speed or small slope, etc.), HDC is inoperative, the driver must maintain control of the vehicle at all times and use brake applications to ensure safety.

The HDC system is an auxiliary function specially designed for driving on acute downhill gradients. The system reduces the speed by applying brake force, thus assisting the driver to drive on acute downhill surfaces with low speeds.

Please DO NOT use this function when driving on the ordinary roads.

When the HDC is working, the brake system may generate strong vibrations or noise. It is normal during the operation of HDC.

Note: *During the operation of the Hill Descent Control (HDC) system, please engage a lower gear on MT models to prevent the engine stalling; on AT models, please do not move the shift lever to the "N" position or the HDC function may be deactivated.*

STARTING & DRIVING

HDC System On/Off

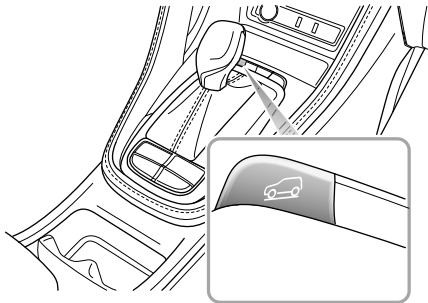

When the START/STOP Switch is switched ON/RUNNING, HDC system defaults to off. Use the switch function within the infotainment system to turn the HDC system on/off.

Normally, HDC system has four states:

- 1 Standby: Press the HDC switch (ON) to set the system into standby mode, the green HDC warning lamp in the instrument pack will illuminate.
- 2 Operation whilst in Standby mode, when the vehicle is driven down an acute gradient, if the vehicle speed is low, the HDC system will automatically enter the operating state. In this case, the HDC warning lamp in the instrument pack flashes green, this may be accompanied by the working noise of the brake system. The HDC system will attempt to control the vehicle drive down the steep slope smoothly.
- 3 Temporary Deactivation: Press the accelerator or brake pedal beyond a preset limit whilst in operating mode and the HDC system will temporarily suspend operation.
- 4 Off: Press the HDC switch (OFF) to switch the system OFF, the green HDC warning lamp in the instrument pack will extinguish.

Note: *HDC system can work in both forward and backward directions.*

Note: *During HDC system operation the braking system will automatically pressurise and maintain pressure. Operation of the brake pedal during this phase may result in a 'kickback' sensation through the pedal. This is normal for HDC operation.*

HDC ON/Malfunction Indicator Lamp

Refer to "Warning Lights and Indicators" in "Instruments and Controls" chapter.

Anti-lock Brake System (ABS)



ABS cannot overcome the physical limitations of stopping the car in too short a distance, cornering at too high a speed, or the danger of aquaplaning, i.e. where a layer of water prevents adequate contact between the tyres and the road surface.

The purpose of the anti-lock braking system (ABS) is to prevent the wheels from locking while braking, thereby enabling the driver to retain steering control of the car.

The fact that a car is fitted with ABS must never tempt the driver into taking risks that could affect his/her safety or that of other road users. In all cases, it remains the driver's responsibility to drive within normal safety margins, having due consideration for prevailing weather and traffic conditions.

Under normal braking conditions, ABS will not be activated. However, once the braking force exceeds the available adhesion between the tires and the road surface, thereby causing the wheels to lock, ABS will automatically

STARTING & DRIVING

come into operation. This will be recognisable by a rapid pulsation felt through the brake pedal.

Braking in an Emergency



DO NOT pump the brake pedal at any time; this will interrupt the operation of ABS and may increase the braking distance.

If an emergency situation occurs, the driver should apply full braking effort even when the road surface is slippery. ABS will ensure that the wheels do not lock and that the car is brought to a halt in the shortest possible distance for the prevailing road surface conditions.

Note: On soft surfaces such as powdery snow, sand or gravel, the braking distance produced by the ABS system may be greater than that for a non-ABS system, even improved steering would be experienced. This is because the natural action of locked wheels on soft surfaces is to build up a wedge of material in front of (or to the side of, if steering) the tyre contact patch. This effect assists the car to stop when braking or to change direction when steering.

No matter how hard you brake, you are still able to continue steering the vehicle as normal.

IMPORTANT

ABS can not reliably make up for the driver's mis-operation or lack of experience.

ABS Malfunction Indicator Lamp

Refer to "Warning Lights and Indicators" in "Instruments and Controls" section.

Note: The normal (non-ABS) braking system remains fully operational and is not affected by partial or full loss of ABS. However, the braking distances may increase.

Auto Hold *



When auto hold stops the vehicle, for reasons such as engine shut-down, releasing the seat belt or pressing the auto hold switch, the electronic parking brake is applied. It cannot be guaranteed that the vehicle will be stabilised in all cases. For example, the rear wheels are on a slippery road surface, or the vehicle incline is too great (larger than 20%). Please make sure that the vehicle is safely stabilised prior to exiting.



DO NOT take any extra risks when driving due to the fact the vehicle is fitted with additional convenience functions. The driver should pay full attention and observe the surroundings even if the vehicle is equipped with auto hold system.



The auto hold function cannot guarantee the stability of the vehicle when starting off or braking on hills especially on slippery or icy surfaces.



DO NOT leave the vehicle when the engine is operating and the auto hold is active.



Auto hold cannot guarantee the electronic parking brake operation in all cases where the power system is shut down. Please ensure the electronic parking brake is applied and the vehicle is stabilised prior to exiting the vehicle.



The auto hold function should be switched off during the use of automatic car washes, the electronic parking brake may suddenly apply and cause vehicle damage.

If the vehicle is required to stop frequently for a length of time (such as traffic lights, traffic queues or stop/start), and the engine is running, the auto hold system assists in stabilising the vehicle, enabling you to remove your foot from the brake pedal when the vehicle is stationary and the Auto Hold active.

Auto hold has 3 main states:

- I Off: Function in Off state.

STARTING & DRIVING

- 2 Standby: Function in Standby state. The function is active but the vehicle has not stopped. Once the vehicle has stopped, and all other conditions are met, the system will automatically select Park.
- 3 Parking: Function in Parked state. In this state the green (P) indicator on the instrument pack illuminates.

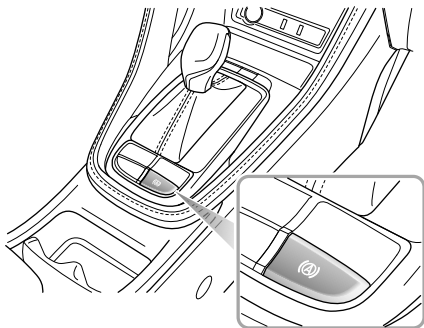

With the driver's seat belt fastened, the door closed and the engine running, press the auto hold switch to switch the auto hold function from Off to Standby state.

With the brake pedal firmly pressed and the vehicle completely stopped, the auto hold function will switch from the Standby state to the Parking state.

When the auto hold is in the Parking state, engaging forward or reverse gear and pressing the accelerator will automatically release the auto hold function.

In some circumstances such as releasing the seat belt, switching off the engine or remaining static for a length of time it will result in the vehicle exiting the auto hold Parking state. At this time the electronic parking brake will remain applied and will require the driver to release it using the switch.

Note: *With the brake pedal pressed, operating the switch to turn the auto hold off, the system will NOT apply the parking brake.*

Note: *It is recommended to turn off the auto hold function when reversing into the garage.*

Emergency Braking Hazard Warning Lights Control (HAZ)

If the vehicle is travelling in excess of 31 mph (50 km/h) and the driver makes an emergency braking manoeuvre, the hazard lights will be operated to indicate this to other drivers.

Note: *If the hazard warning lights are being operated manually, this suspends the HAZ function.*

When the emergency braking manoeuvre is exited (no severe deceleration detected) then the function will be switched off after a few seconds.

Note: *As the car speed drops to below 6 mph (10 km/h) and the system no longer flashes the brake lamps, the hazard warning lamps will illuminate automatically. Short press the hazard warning lamp switch or increase your speed to above 12 mph (20 km/h) for 5 s to switch off the hazard warning lamps.*

Active Rollover Protection (ARP)



The ARP system cannot overcome the laws of physics. It is a driver aid to assist the stability of the vehicle and under extreme conditions. It is not a guarantee that the car will not roll over.

In cases where the vehicle has a high centre of mass, rapid or excessive dual direction lane changing may create a roll condition. ARP may use the braking system to apply certain brakes to try and correct the condition and assist in preventing rollover.

Note: *During ARP application the steering characteristics of the vehicle may be noticeably different from normal.*

STARTING & DRIVING

Parking Brake *



DO NOT drive with the parking brake applied, or apply the parking brake while the car is in motion. This could result in loss of control, prevent the ABS from functioning correctly, and may even cause damage to the rear brakes.

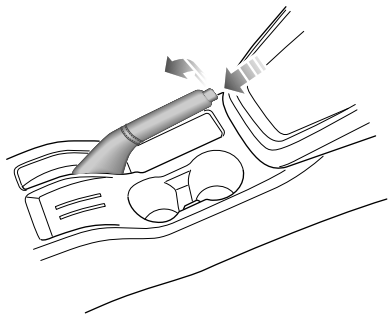

The parking brake operates on the rear wheels only. To apply the parking brake, pull the lever up. Always apply the parking brake fully whenever you park the car.

To release, pull the lever up slightly, press the button (arrowed in illustration) and fully lower the lever. When parking on a steep slope, do not rely on the parking brake alone to hold the car.

Electronic Parking Brake (EPB) *



In the event of EPB malfunction where EPB release is not possible, please consult an MG Authorised Repairer in order to carry out an emergency manual release of the parking brake.

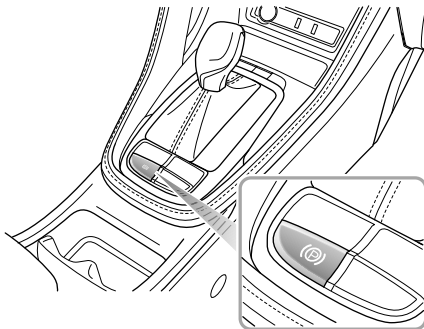

Applying the EPB

While the vehicle is stationary, the EPB can be applied. Ensure the EPB is applied every time the vehicle is left or parked.

- Press the brake pedal, pull the EPB switch upward until the indicator in the EPB switch illuminates.
- If the indicator in the EPB switch and the indicator in the instrument pack illuminates, (P) the EPB is applied.
- If the EPB malfunction indicator lamp (P) in the instrument pack remains on, it indicates that a fault has been detected. Please contact an MG Authorised Repairer immediately.

Note: *An audible motor noise may be heard when applying or releasing the EPB.*

IMPORTANT

- In the event of a flat battery or power failure, it is not possible to apply or release the EPB. In such a case, 'jump leads' shall be used for emergency engine start, please refer to "Emergency Starting" in "Emergency Information" chapter.

STARTING & DRIVING

Releasing the EPB

- Switch on the ignition, press the brake pedal, and press the EPB switch.
- If the indicator in the EPB switch and the indicator in the instrument pack (P) are extinguished, the EPB is released.

Start Assist

The EPB can predict the driver's intention and automatically release the EPB.

If the driver's seat belt is fastened, the engine is started up, D or R gear is selected and the accelerator pedal is depressed for start off, the EPB will automatically release.

Emergency Braking Function



Inappropriate use of the EPB can lead to accidents and injuries. Do not apply the EPB for vehicle braking, unless in emergency.



During emergency braking using the EPB, DO NOT switch off the ignition, this could result in serious injury.

When the car is in motion, in case of any emergency, such as the car can not be stopped by the brake pedal, it can be decelerated by pulling up and holding EPB switch.

- Pull the EPB switch upward and hold to realise the emergency braking. Continuous acoustic alarm will sound simultaneously during emergency brake.
- To cancel the emergency braking process, release the EPB switch.

Automated Stop/Start — Intelligent Fuel Saving System

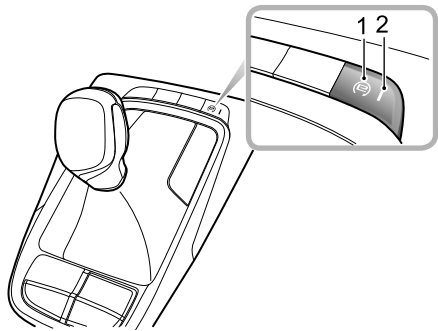

- 1 Main Switch
- 2 Main Switch Indicator Lamp

Engine Stop/Start has been incorporated into vehicles in an effort to reduce emissions. As the name suggests the system will allow the engine to be switched off when engine power is not required and then automatically be restarted when it is.

This system defaults “on” with the START/STOP Switch in the ON/RUNNING position, the Main Switch Indicator Lamp is on (2 shown in fig) and can be turned off by pressing the Main Switch (1 in the fig). The lamp in the switch will extinguish.

Note: *If vehicle is driving through deep water, please use Main Switch (1 in the fig) to shut down Stop/Start intelligent fuel saving system.*

STARTING & DRIVING

Automatic Shutdown of Engine



Although the engine is not running after an automatic stop, the system is prepared to auto start therefore the following actions could be dangerous:

- 1 Leaving the vehicle while the seat belt is still buckled, or there is a substitute seat belt buckle inserted.*
- 2 Carrying out work or checks in the engine compartment.*
- 3 Refuelling the vehicle, the START/STOP Switch must be switched "OFF" or the key removed from the switch.*
- 4 Vehicles with automatic transmission: Leaving the vehicle while the gear selector is still in Drive position (R/D/S).*

Engine Auto Stop Conditions

Engine Auto Stop Conditions (Under Start Stop Control, Instrument Pack Indicator Lamp  on)

- Vehicle is stationary, i.e. speed =0 mph or km/h.

- The vehicle speed prior to stopping exceeded 6 mph (10 km/h).
- Vehicles with manual transmission: Gearbox must be in neutral and clutch pedal is released.
- On automatic derivatives if D is selected and the brake pedal pressed the engine will automatically stop. Shifting the gear selector to P/N and releasing the brake pedal will maintain the engine shutdown status.
- The driver's door is closed and seat belt is secured.
- The bonnet is closed.
- Transmission in Drive with footbrake pressed. (auto only)
- No demands on the steering. (auto only)

Stop/Start Prohibited

Start Stop will not operate if:

- Coolant temperature is below a preset limit .
- Front defrost is on.
- Battery power is below a preset limit.
- The vacuum in the braking system is below a preset limit.

- Starter motor temperature is above a preset limit.
- Reverse gear selected or has been selected prior to parking.
- Heating or cooling demand is too great.
- Vehicle is standing at excessive angles. (auto only)

Automatic Engine Start

With the engine stopped in the automatic Stop/Start condition, the following driver actions will cause an automatic restart, at this time the instrument pack indicator lamp  is off.

- Models with automatic transmission and in D position: release the brake pedal, or shift out of Drive position.
- Models with manual transmission: Transmission in Neutral position: press the clutch pedal or accelerator pedal.
- Vehicles with automatic transmission: Release the brake pedal with the shift lever in D position, or depress the brake/accelerator pedal with the shift lever in P/N position, or shift the lever to Drive(R/D/S) position.

With the engine stopped in the automatic Stop/Start condition, the following actions will cause an automatic restart.

- Battery power falls below a preset limit.
- The vacuum in the braking system falls below a preset limit.
- The vehicle begins to move.
- Main Switch (I in the fig) is pressed.

At this time the instrument pack indicator lamp  will extinguish to indicate engine start phase.

Start Inhibition

Note: *When a vehicle fitted with a manual transmission is under automatic Stop/Start control and the engine is required to restart, but neutral position is not selected, the engine will restart when neutral position is selected.*

If any of the following conditions occur during automatic engine stop, the engine can only be restarted using the key, during this time the instrument pack indicator lamp  will extinguish.

- The driver side seat belt is unbuckled.

STARTING & DRIVING

- The driver side door is open.
- Bonnet is open.

At this time the instrument pack indicator lamp  will extinguish to indicate engine start phase.

Stall Assist

This function is available once the Stop/Start intelligent fuel saving system is enabled without any inhibiting conditions.

If the engine cuts out, or is stalled whilst Stop/Start is enabled, selection of neutral and pressing the clutch pedal will automatically restart the engine.

Note: *Extremely low battery power may result in the engine not re-starting automatically, or even using the key. In this instance, external power is needed to start the engine or the battery will require re-charging. See the section 'Emergency Starting' in the 'Emergency Information' Chapter.*

Battery



When charging the battery, starting the car with an external power source or supplying power from the vehicle, the negative cable must be connected to a suitable position on the vehicle body. Failure to do this will result in inaccurate battery power calculation which will effect automatic Stop/Start control.



DO NOT disconnect the battery sensor unless absolutely necessary. removal will result in inaccurate battery power calculation which will effect automatic Stop/Start control.

Note: *Failure to operate within the following guidelines will effect battery performance and automatic Stop/Start control:*

- I** *After power interruptions (battery disconnection) the automatic Stop/Start function will be suspended until the vehicle is left in a locked state*

for at least 4 hours whilst the system relearns the state of the battery.

- 2 If the vehicle is run continually for more than 100 hours uninterrupted, the Stop/Start function will be suspended until the vehicle is left in a locked state for at least 4 hours whilst the system relearns the state of the battery.*
- 3 If the battery requires replacement, ALWAYS use a genuine part to the manufacturers specification.*

Failure to adhere to this can affect the automatic Stop/Start system.

Automated Stop/Start Intelligent Fuel Saving System Failure

In the event of a Stop/Start Intelligent Fuel Saving System failure, contact an MG Authorised Repairer.

The Stop/Start Intelligent Fuel Saving System can be effected by faults within other vehicle systems - in the event of failure contact an MG Authorised Repairer.

Starter Inoperative, Serious Battery Capacity Loss

In the case of serious battery power loss, automatic Stop/Start and key start may not be possible. In this case see the section 'Emergency Starting' in the 'Emergency Information' Chapter.

STARTING & DRIVING

Stability Control System (SCS) and Traction Control System (TCS)

Stability Control System (SCS)

SCS is designed to assist the driver in control of driving direction. The SCS is automatically activated after the engine is started.

When SCS detects that the vehicle is not moving in the intended direction, it will intervene by applying brake force to selected wheels or through the engine management system to prevent sliding and assist in bringing the car back to the right direction.

Traction Control System (TCS)

The purpose of electronic traction control is to aid traction, thereby helping the driver to maintain control of the car in situations where one or both of the driving wheels are spinning (for example, if one wheel is on ice and the other on tarmac). The traction control system monitors the driving speed of each wheel individually. If spin is detected on one wheel, the system automatically brakes that wheel, transferring torque to the opposite,

non-spinning wheel. If both wheels are spinning, the system will reduce engine speed in order to regulate wheel rotation until traction is regained.

Switching On/Off

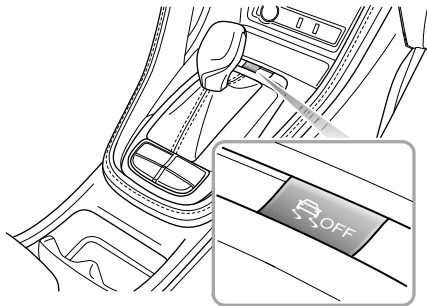

With the START/STOP Switch is switched ON/RUNNING, SCS and TCS will automatically turn on. And you can turn them off after the engine is started.

- Press SCS switch (less than 2 seconds) to turn off TCS.
- Press SCS switch (longer than 2 seconds) to turn off SCS and TCS.

Note: *Press the SCS switch (more than 10 seconds), it will be regarded as misoperation.*

- To recover the operation of SCS and TCS, press SCS switch once again.

Note: *Disabling SCS and TCS will not affect the operation of ABS. Always disable TCS when driving with snow chains fitted.*

Stability Control/Traction Control Warning Lamps

Refer to "Warning Lights and Indicators" in "Instruments and Controls" section.

STARTING & DRIVING

Cruise Control System

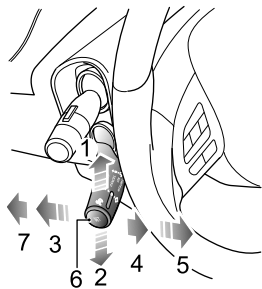

- Acceleration (1)
- Deceleration (2)
- Cruise Cancel (3)
- Cruise Standby (4)
- Cruise Resume (5)
- Cruise Set (6)
- ASL Standby (7)

Cruise control enables the driver to maintain a constant road speed without using the accelerator pedal. This is particularly useful for motorway cruising, or for any

journey where a constant speed can be maintained for a lengthy period.

Cruise Control System Activation

Cruise control system is operated with a lever located, at the left side of the steering wheel underneath the lighting stalk switch.

With the START/STOP Switch in position ON/RUNNING, if the lever switch is in the 'ASL Standby' position (7 in figure), then the cruise control is OFF. To set the cruise control to 'Standby' pull the lever switch to 'Cruise Standby' (4 in figure), the yellow indicator lamp  in the instrument pack will illuminate indicating the system is in 'Cruise Standby' mode.

With the system in 'Standby' when the current vehicle speed is above 25mph (40km/h), press the 'Cruise Set' button (6 in figure). The indicator  in the instrument pack will change to green and the cruise control will enter and activated state. The operating range is 25 - 125 mph (40 - 200 km/h).

The target speed of the cruise system will be set at the current speed, and the cruise system will take effect. At this time, the cruise control system will maintain the set speed without pressing the accelerator pedal.

Note: *The set speed held in the cruise control memory will be cancelled when either the cruise control lever is switched to "ASL Standby" position (figure 7) or the START/STOP Switch turned off.*

Target Cruise Speed Adjustment

When the cruise control is active, the 'target speed' can be increased or decreased:

Push the lever switch upwards (1 in figure), this will increase the speed.

Push the lever switch downwards (2 in figure), this will decrease the speed.

Release the lever switch when the desired speed is reached.

Push the lever switch upwards or downwards briefly to increase/decrease the vehicle target speed in increments of

1 mph(1 km/h), then the vehicle will accelerate/decelerate to the new target speed.

Pressing the accelerator at any time will override the cruise control and allow acceleration to undertake manoeuvres such as overtaking. Releasing the accelerator will return the vehicle to the set target speed.

Pause/Stand By

Cruise control will be disengaged and set to 'Standby' if:

- Lever switch moved to 'Cruise Cancel' position (3 in figure).
- Brake pedal pressed.
- Auto gear lever moved to P, R or N.
- Manual gear-change made.
- Clutch pedal pressed.
- Conditions initiate SCS intervention.
- An incline causes excessive decline in speed.

Resume

If the cruise control remains on after the disengagement, moving the lever switch to 'Cruise Resume' (5 in figure)

STARTING & DRIVING

will reinstate the target speed to the setting prior to disengagement.

Note:

- **Never use the cruise control system in the reverse gear.**
- **DO NOT use the cruise control in unsuitable conditions, such as on slippery surfaces, excessively heavy rain or in traffic conditions that DO NOT suit maintenance of constant speeds.**
- **When not in use, ensure the lever switch is in the 'ASL Standby' position (7 in figure).**
- **When the automatic transmission is in "Sport" mode, it is not recommended to use the cruise control system.**
- **During the operation of cruise control system, the actual speed may deviate from the target cruise speed to some extent due to road conditions (such as uphill, downhill, etc).**
- **If the actual speed is excessively lower than the target speed or SCS is activated due to the hill or road surfaces, the cruise control system may automatically revert to standby mode.**

- **DO NOT operate the switch for excessively long periods, or press multiple switches simultaneously, this may cause the system to fail. If this situation occurs, when it is safe to do so, cycle the ignition.**

Active Speed Limit (ASL) System

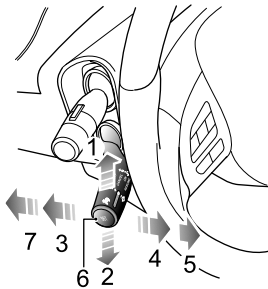

- | | |
|-------------------------|-------------------|
| 1. Speed Limit Increase | 5. Cruise Resume |
| 2. Speed Limit Decrease | 6. Set (Activate) |
| 3. Cruise Cancel | 7. ASL Standby |
| 4. Cruise Standby | |

The Active Speed Limit (ASL) system is designed to control the vehicle speed keeping it below a speed set by the driver.

The ASL system shares the same lever switch as the cruise control system, located to the left of the steering wheel below the indicator stalk. The switch can be toggled between both functions, however only one function can operate at any one time.

Activate

The desired target speed of the ASL system is displayed in the instrument information cluster, refer to "Information Centre" in the "Instruments and Controls" section. With the START/STOP Switch in position ON/RUNNING and the lever switch in "ASL Standby" (7 in figure), the ASL function is in standby mode by default, briefly moving the lever switch up/down (1,2) adjusts the target speed of the ASL. The range of target speed adjustment is 20 - 130 mph.

The target speed limit value will be increased or decreased by 5 mph every time the lever switch is briefly moved upwards or downwards.

STARTING & DRIVING

Pressing the "Set" button (6 in figure) will activate the ASL system and set the speed limit. The ASL indicator lamp in the instrument pack will illuminate.

When activated if the vehicle speed is greater than the user inputted target speed the system will immediately begin to slow the vehicle to the inputted target.

Kick Down

With the system active if it is necessary to accelerate the vehicle e.g. overtaking manoeuvre, the system can be overridden by pressing the accelerator pedal passed a kick down position. The kick down position is approximately at the overall accelerator pedal travel pressed. Once the kick down position has been reached the ASL system enters a standby state and returns the vehicle operation to the user, accelerating according to the demand from the accelerator pedal.

After a kick down event, once the vehicle speed has dropped below the target speed originally controlled to, the ASL system will automatically resume and control the vehicle to the target speed retained within the system.

Suspending ASL

When ASL is active, to suspend the feature press the "Cruise Standby" button (4) and the ASL system will exit to the standby state returning control to the accelerator pedal.

Note: When suspended via the "Cruise Standby" button (4) the previously inputted target speed will be retained within the system memory in the case that the system is reactivated.

Resuming ASL

If the system has been placed in a standby state with a retained target speed the system can be reactivated to the previously stored target speed by pressing the "Set" button.

Note: After the ignition is switched OFF, the target speed previously stored will be erased. In the interest of economy and safety, it is recommended to select different target speeds according to different driving and road conditions.

Overshoot of Target Speed and Warning

The system is designed to control the vehicle speed to within +/- 1.5 mph (2 km/h) of the inputted target speed. However, the feature does not incorporate vehicle braking assist, therefore if the ASL system is attempting to control vehicle speed on a steep downhill incline the inertia of the vehicle may force the vehicle speed over the intended target speed.

If at any time the vehicle speed increases 2 mph (3 km/h) more than the desired target speed the system informs the user with continuous visual and periodic audible warnings. Once the desired target speed has been maintained the warnings are removed.

Note: *If the target speed has been deliberately exceeded i.e. Kick Down, only a visual warning is displayed.*

STARTING & DRIVING

Parking Aid System *

Ultrasonic Sensor Parking Aid *



The purpose of the parking aid is to assist the driver in reversing! The sensors may not be able to detect obstacles of certain type, e.g. narrow posts or small objects no more than a few inches wide, small objects close to the ground, objects above the tailgate and some objects with non-reflective surfaces.



Keep the sensors free from dirt, ice and snow. If deposits build up on the surface of the sensors, their performance may be impaired. When washing the car, avoid aiming high pressure water jets directly at the sensors from close range.

Rear Parking Aid

The ultrasonic sensors in the rear bumper monitor the area behind the vehicle to search for obstacles. If any obstacle is detected, the system will calculate its distance from the rear of the vehicle and communicates the message to the driver by sounding warning chimes.

Parking Aid in Operation

When the START/STOP Switch is in the ON/RUNNING position, the rear parking aid is enabled automatically when reverse is selected, it is switched off as soon as reverse is disengaged. A short beep is given by the parking aid within 1 second after selecting reverse to indicate that the system is operating normally.

The entertainment system screen will display a silhouette image of the car showing the object distance values for the sensor.

Note: If a longer, higher pitched sound is emitted for 3 seconds when reverse is selected this indicates a fault in the system. In this case seek assistance from your MG Authorised Repairer.

With the parking aid enabled, when obstacles are detected, the system will give sounds in different frequencies (there might be blind areas).

- Once the obstruction is within 30cm range of the rear bumper, the beeps will merge into a continuous warning.

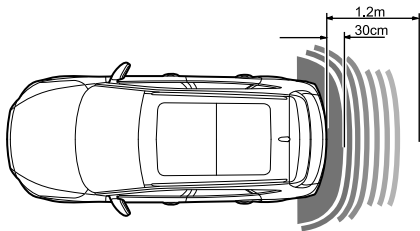

- If there is an obstacle within 1.2m range from the rear sensors, the system starts to emit a beeping sound. As the vehicle moves closer to the obstacle, the beeps are transmitted more rapidly.

STARTING & DRIVING

360 Panoramic Imaging System *



The purpose of the 360 panoramic imaging system is to assist the driver during reversing! The cameras have a limited field of view and cannot detect obstructions outside the field of view.



Although the entertainment display can provide high-definition images around the vehicle, please still pay attention to the current actual road conditions for your driving safety.

With the 360 panoramic imaging system working, the display interface will show a 360° panoramic image of the vehicle to facilitate the observation of the surrounding environment to make driving safer.

- When the reverse gear is selected, the system will automatically switch to the display interface of a 360° panoramic image, this will appear in the entertainment display.

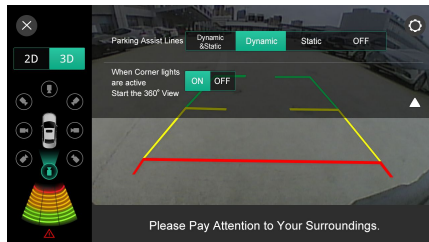

- Touch or press the 360° View button to enter into the display interface of the 360 panoramic imaging system, you are then able to touch buttons on the display to check images from different angles of view of the vehicle to provide a much safer driving environment.
- Touch the 2D or 3D button on the display to enter into the display interface of the 2D or 3D panoramic imaging system, you are then able to touch different areas around the vehicle (as displayed on the LH side of the screen) to check images from different angles of view to provide a much safer driving environment.
- Touch the Setting button in the upper right corner of the screen to open the 'Settings' interface, here you are able

to switch the "when corner lights/indicators* are active start the 360° view" function ON/OFF. When a forward gear is selected and the left/right corner light/indicator* is on, the 360 panoramic image system will display the corresponding left/right view.

- Touch the Setting button in the upper right corner of the screen to open the 'Settings' interface, here you are able to set the parking aid line to static, dynamic, dynamic + static, and off state.

Note: *When the shift lever is placed in forward gear position, in no case can 360 panoramic imaging system be enabled as long as the vehicle speed exceeds or equals to 10mph (15 km/h).*

STARTING & DRIVING

Rear Driver Assistance System *

System Overview



The effective recognition capabilities of the rear sensors can be limited by objects such as roadside buildings, guardrails, changes in pitch angle of the car due to heavy loading, road conditions such as bends or bumps or weather conditions such as snow and ice etc. Any of the above may trigger a false alarm.



The rear driver assist system may not provide adequate warning of very fast approaching vehicles or operate correctly on tight curves of 500m radius or less.



The rear driver assist system will not operate correctly whilst towing a trailer or caravan.



The system has limitations and may not be able to warn of vehicles approaching at high speeds.



The rear driver assistance function is only an aid, it is NOT a substitute for the attention of the driver. The driver must always remain in control, observe the surroundings and drive safely.



The correct operation of the rear sensors will be compromised if they are misaligned due to accident damage. This may cause the system to automatically shutdown.



To ensure that the radar sensors work correctly, the rear bumper should be kept free of snow and ice and must not be covered.



Use of non recommended materials or paint on rear bumper repairs may have a detrimental effect on the operation of the rear sensors. Please only use recommended materials.

The rear driver assistance system includes blind spot detection (BSD), lane change assist (LCA), and rear cross traffic alert (RCTA) functions.

The rear driver assistance modules are mounted at the rear of the vehicle on each side, they can assist in detecting vehicles behind or to the side of your vehicle.

The warning lamps to support this system are located within the LH and RH door mirror glasses, they will illuminate or flash to warn of an approaching object or car to assist you in manoeuvring the car safely.

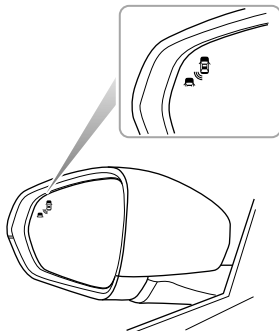

Note: The radar requires calibration on new vehicles or for vehicles of where a rear detecting radar sensor has been replaced. The rear detection radar sensors possess an automatic calibration function to compensate for installation error within a certain range. When the vehicle is running, the radar will automatically enter the calibration state. During the calibration process, the system will provide limited functions, and the alarm may be inaccurate. Upon

STARTING & DRIVING

completion of the calibration, the system will resume all functions.

Switching the System Functions On/Off

The rear driver assist system function and sub system switches can be accessed via the infotainment screen.

Select: 'Vehicle Settings', 'Driving Assist' and 'Rear Driving Assist' (you may have to scroll left or right to access this option). Select ON/OFF to activate/deactivate the system. A warning message to alert you of your choice will be displayed in the message centre in the instrument pack.

When the vehicle is restarted, the system will keep the previously stored switch settings.

System Functions

Note: The detection area, collision time threshold value and vehicle speed provided in the system function description are just for your reference.

Blind Spot Detection (BSD)

When the vehicle is driving forward, the system will monitor the motor vehicles located in the blind zones of the left and right exterior mirrors. When the conditions for activating the blind spot detection function are met, the warning lamps in the corresponding mirror will illuminate. Subsequent operation of the relevant indicator will cause the warning lamp in the mirror to flash to remind the driver of an approaching vehicle.

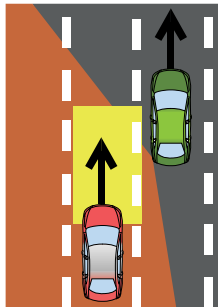

of the vehicle, the monitored areas are 2m ahead , 7m behind the rear of the vehicle, and 4.7m from the side of the vehicle.

Note: *The warning lamps will not illuminate whilst you are overtaking another vehicle and your speed is greater than that of the vehicle you are passing, even though it is in the blind zone.*

The conditions for activating the blind spot detection function include:

- 1 Rear driver assistance system is in the ON state and no faults are present in the system.
- 2 Blind spot detection (BSD) function is enabled.
- 3 The vehicle speed is above 20mph (30km/h).
- 4 There are motor vehicles in the blind zone of the vehicle. The system monitors both the left and right

STARTING & DRIVING

Lane Change Assist (LCA)

When the vehicle is driving forward, the system will monitor the motor vehicles approaching rapidly in the adjacent lanes. When the indicators are activated, and the conditions for activating the lane change assist function are met, the system will flash the warning lamp within the respective mirror to warn the driver of an approaching vehicle. This aims to help avoid collisions when changing lanes.

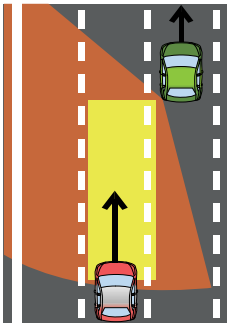

The conditions for activating the lane change assist function include:

- 1 Rear driver assistance system is in the ON state and no faults are present in the system.
- 2 Lane change assist (LCA) function is enabled.
- 3 The vehicle speed is above 20mph (30km/h).
- 4 The speed of the approaching vehicle is higher than the speed of your vehicle.
- 5 The approaching vehicle enters the detection area of the LCA, the monitored areas are 7 - 70m behind your vehicle and 4.7 m to the side of your vehicle.
- 6 The approaching vehicle is likely to have a collision with your vehicle within 3.5 seconds.

Rear Cross Traffic Alert (RCTA)

When the vehicle is reversing, the system will monitor vehicles approaching from the left and right rear. When the conditions for activating RCTA function are met, the warning lamps in the mirrors on the corresponding side will illuminate, simultaneously a warning triangle icon for the corresponding side will be displayed in the infotainment screen to alert the driver to the situation.

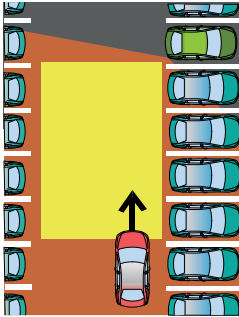

The conditions for activating the rear cross traffic alert function include:

- 1 Rear driver assistance system is in the ON state and no faults are present in the system.
- 2 Rear cross traffic alert (RCTA) function is enabled.
- 3 The vehicle is in Reverse gear.
- 4 The vehicle speed is less than 5mph (9km/h).
- 5 The speed of the vehicle being monitored is above 5mph (9km/h).
- 6 The motor vehicle drives across the system detection areas. The areas monitored to the left and right of the vehicle are 5m behind the rear of the vehicle, and 25m from the side.
- 7 The approaching vehicle is likely to have a collision with your vehicle within 2.5 seconds.

STARTING & DRIVING

Tyre Pressure Monitoring System (TPMS)



TPMS cannot replace routine maintenance and check of the tyre condition or pressure.



If radio transmission devices such as mobile telephones or wireless headsets are used in close proximity to the vehicle it may result in interference with the TPMS and could register as a fault.

Note: *TPMS only gives the driver a warning when the tyre pressure is low, it will not inflate the tyre.*

TPMS uses pressure sensors built into tyre valves to continuously monitor pressure and transmits signal to ECU inside the vehicle using RF signals. If it deduces that the pressure of that tyre has fallen below the predefined limit of the system, the warning light on the instrument pack will illuminate (always yellow). For more information, please refer to 'Instrument Pack' in 'Instruments and Controls' section. Check your tyres at the earliest opportunity and

reinflate to the correct pressure. Please refer to 'Tyre Pressure (Cold)' in 'Technical Data' section.

System Malfunction



This system is self-monitoring, if a malfunction is detected, the TPMS warning lamp (yellow) on the instrument pack will flash for 90 seconds first and then illuminate.

Note: *When a puncture is detected, the system will require some time to analyse information prior to illuminating the warning lamp.*

Under certain conditions the warning light may illuminate when a fault is not present, these conditions include:

- A non recommended tyre fitted (including spare tyre).
- Rough terrain driving for excessive periods.
- Bending or mountain type terrain driving for excessive periods.
- TPMS will not respond immediately if a tyre 'blows out'.

TPMS Self-learning

The TPMS system is a 'self learning' system, after resetting tyre pressures it will be necessary to allow the system to go through a self learning process. This is done by driving the car, during this process the system is suspended and the data displayed may not be correct. If sensors or receiver module are replaced the system requires programming, consult an MG Authorised Repairer. If the wheels are swapped or rotated the system requires reprogramming to learn the new transmitter positions, consult an MG Authorised Repairer.

STARTING & DRIVING

Load Carrying



DO NOT exceed the **gross vehicle weight** or the **permitted front and rear axle loads**. **Failure may result in vehicle damage or serious injury.**

Load Space



Ensure that the rear seat backrests are securely latched in the upright position when loads are carried in the load space behind the seats.



If the boot lid (or tailgate) can not be closed due to the type of cargo loaded, be sure to close all windows during driving, select the face distribution mode of the air condition, and set the blower to maximum speed, so as to decrease exhaust fumes entering the vehicle.

When luggage carried in the boot, always ensure heavy items are placed as low and as far forward as possible, so

as to avoid the cargo shift in the event of an accident or sudden stop.

Drive carefully and avoid emergency braking or maneuvers when large or heavy items are carried.

Driving with the boot lid (or tailgate) open is very dangerous. If the load being carried requires the boot lid (or tailgate) to be open, please ensure the cargo and the boot lid (or tailgate) are suitably secured and every measure is taken to prevent exhaust fumes entering the vehicle.

IMPORTANT

Traffic regulations must be observed when loading cargo, if the cargo extrudes the loadspace, appropriate warning measures must be taken to warn other road users.

Internal Loading



DO NOT carry unsecured equipment, tools or luggage that could move, causing personal injury in the event of an accident, emergency braking or hard acceleration.



DO NOT obstruct the driver and passengers to keep right sitting posture and observation with loads.

Folding the rear seats can increase luggage space, refer to "Rear Seat" in "Seats and Restraints" chapter.

When cargo is loaded in the vehicle, place it at a position as low as possible and ensure that it is tightly secured, so as to avoid personal injury caused by cargo movement when traffic accidents or emergency brakes occur. If the cargo has to be put on a seat, no one is allowed to sit on that seat.

General Towing Safety

Your vehicle can tow a trailer if you carefully observe load limits, use approved equipment, and follow the towing guidelines. Always check load limits before towing.

Towing loads in excess of the maximum towing weight can seriously affect vehicle handling and performance, and could damage your vehicles engine and drive-train.

Note: Exceeding any load limits advised by MG Motor UK Ltd is dangerous. Consult the recommended load limits and loading prior to any journey.

Check the loading of your vehicle and trailer carefully before starting to drive.

Trailer hitch load should never exceed the limit advised by MG Motor UK Ltd.

Note: Excessive towing loads reduce front tyre traction and steering control, too little trailer nose load can make the trailer unstable and cause it to sway.

Tow bars: Only genuine MG approved tow bars should be fitted to your vehicle. Only use the attachment method specified by the vehicle manufacturer for securing the

STARTING & DRIVING

towing hitch. Contact your authorised MG dealer for more information.

Safety chains: Safety chains must be used as a precautionary measure should the trailer become unintentionally unhitched. Make sure the safety chain is securely attached to both the trailer and the vehicle prior to departure.

Altitude: Your engine delivers less power at higher altitude. If you tow a trailer in a mountainous area you should reduce the combined vehicle and trailer weight by 10% for every 1000m of elevation.

Gradients: Where possible, when towing, you should plan your journey to avoid steep gradients. The advised brake towing mass stated assumes a maximum gradient capability of 12% where possible it is recommended you drive on gradients less than 12%. Follow the trailer associations recommendations for suitable roads.

Running in period: Avoid towing a trailer during your vehicles first 1000 km or 625 miles.

Stop/Start function: Manually switch the Automated Stop/Start function OFF when towing. The trailer weight

can affect your vehicles braking efficiency if Automated Stop/Start is activated on a hill while towing a trailer.

Emergency Information

226 Hazard Warning Devices

228 Emergency Starting

230 Vehicle Recovery

*235 Tyre Repair and Wheel
Replacement*

242 Fuse Replacement

250 Bulb Replacement

EMERGENCY INFORMATION

Hazard Warning Devices

Hazard Warning Lights

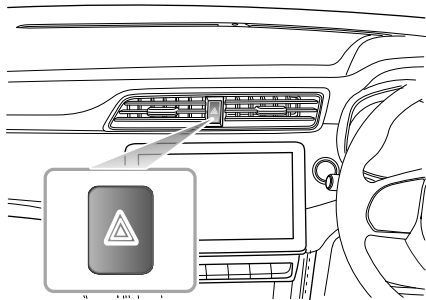

Note: Before you stop or slow the car in an emergency, always press the hazard warning switch. All the direction indicators will flash together to warn other road users when your car is causing an obstruction or

is in a hazardous situation. Remember to switch off before driving away.

Warning Triangle

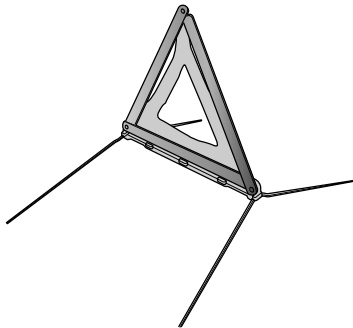

The warning triangle supplied with your car is stowed in the loadspace.

If you have to stop your car on the road in an emergency, you must place a warning triangle approximately 50 - 150

EMERGENCY INFORMATION

metres behind the car, if possible, to warn other road users of your position.

EMERGENCY INFORMATION

Emergency Starting

Using Booster Cables

! NEVER attempt to start the engine by pushing or towing.

! Make sure that both batteries are of the same rated voltage (12 volts), and that the booster cables are approved for use with 12 volt car batteries.

! Ensure sparks and naked flames are kept well away from the front compartment.

Using booster cables (jump leads) from a donor battery, or a battery fitted to a donor vehicle, is the only approved method of powering a car with a flat battery.

If the battery from a donor vehicle is to be used, make sure that the vehicles are parked so that the two batteries are adjacent to one another and that both the vehicles do not touch.

Starting the Car



Ensure that each booster cable connection is securely made. There must be no risk of the clips accidentally slipping from the battery terminals (as a result of engine vibration, for example), this could cause sparking, which could lead to fire or explosion.

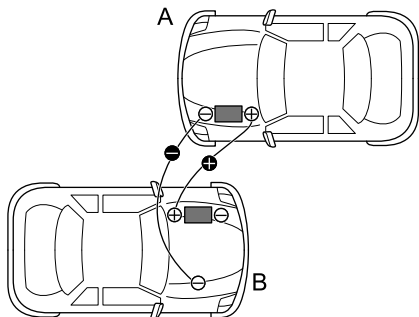

EMERGENCY INFORMATION

Ensure the START/STOP switch is turned off and switch off ALL electrical equipment of BOTH vehicles, then follow the instructions below:

- 1 Connect the RED booster cable between the positive (+) terminals of both batteries. Connect the BLACK booster cable from the negative (-) terminal of the donor battery (A) to a good earth point (an engine mounting or other unpainted surface, for example), as far away from the battery as possible and well away from fuel and brake lines on the disabled vehicle (B).
- 2 Check that the cables are clear of moving parts of both engines, then start the engine of the donor vehicle and allow it to idle for a few minutes.
- 3 Now start the engine of the vehicle with the discharged battery (DO NOT crank the engine for more than 10 seconds). If the disabled vehicle will not start after several attempts, it may need to be repaired. Please contact the MG Authorised Repairer.
- 4 After both the vehicles have normally started, allow the engines to idle for more than 2 minutes before

shutting down the engine of the donor vehicle and disconnecting the booster cables.

Important
NEVER turn on any electrical equipment on the started vehicle before removing the booster cables.

- 5 Disconnecting the booster cables must be an exact reversal of the procedure used to connect them, i.e. disconnect the BLACK cable from the earth point on the disabled vehicle FIRST.

EMERGENCY INFORMATION

Vehicle Recovery

Towing for Recovery

Towing Eye



DO NOT use a tow rope that is twisted - any untwisting force could unscrew the towing eye.

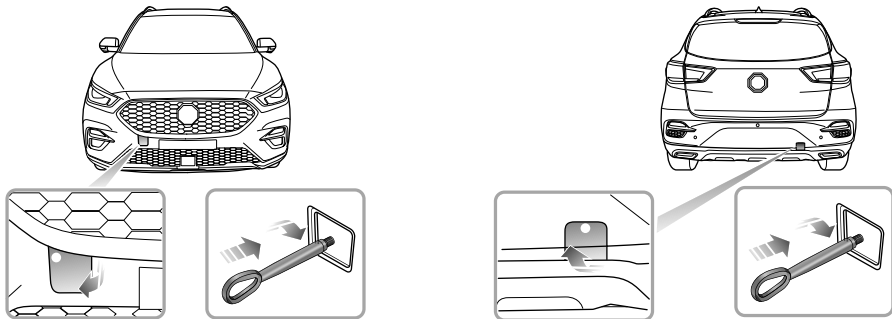

Your car is equipped with a removable towing hook, that can be used at the front or the rear of your vehicle. The towing hook is stored in the tool kit beneath the loadspace floor when not in use.

To fit the towing hook, first press one end of the small cover plate (the white dot in the figure above), then open the small cover plate after the other end is lifted, then screw the towing hook through the small hole into the threaded hole on the bumper beam (as shown in the figure). Ensure the towing eye is fully tightened.

Note: *The towing eye cover may be secured to the bumper by a plastic cord.*

Both towing points are intended for use by qualified recovery specialists to assist in the recovery of your car when a breakdown or accident occur, such as pulling your vehicle onto the trailer, etc. They are not designed for towing other vehicles, and must NEVER be used to tow a trailer or caravan. The car can be towed by using a soft rope, but a hard rod is preferred.

Towing for Recovery



If, due to an electrical fault, potential safety hazards may exist, it is not allowed to put the START/STOP Switch in the ON/RUNNING position.



When towing, DO NOT suddenly accelerate or brake suddenly, this can cause accidents.



The towing speed of a vehicle must not exceed 20 mph (30 km/h), the towing distance shall not exceed 30 miles (50 km).

Suspended Towing

If your car needs to be towed, most qualified recovery specialists will use wheel lift equipment to suspend the front wheels, while the rear wheels remain on the ground. Ensure the parking brake is released, the hazard warning lamps are activated and no passengers are left in the vehicle.

EMERGENCY INFORMATION

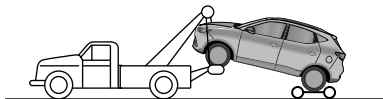
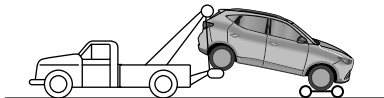
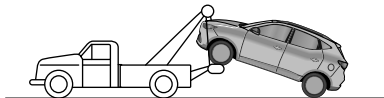

Four-Wheel Touchdown Towing

If vehicle is towed with the four wheels on the ground, observe the following precautions:

- 1 Switch the START/STOP Switch to the ON/RUNNING position to enable the brake lights, wipers and direction indicators to be operated if necessary. If, due to an electrical fault, it is considered unsafe to switch the START/STOP Switch on, the car will need to be recovered on a trailer.
- 2 Place the shift lever in N position (manual transmission), or in N position (automatic transmission).
- 3 Release the parking brake.
- 4 Turn on the hazard warning lamps.
- 5 If the transmission is damaged or has a lack of lubricating oil, DO NOT tow the vehicle with four wheels on the ground.
- 6 DO NOT tow backward with front wheels (drive wheels) on the ground.

EMERGENCY INFORMATION

Transporter or Trailer with Rope

If your car is to be transported on the back of a trailer or transporter, it must be secured as illustrated:

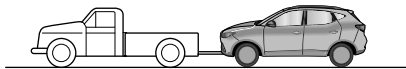

Without the engine running, greater effort will be required to operate the brake pedal and turn the steering wheel. Longer stopping distances will also be experienced.

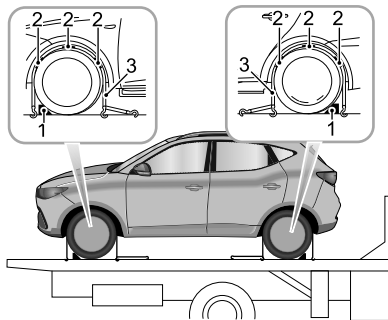

- 1 Position the car on the trailer, apply the parking brake, and place the shift lever in N position (manual transmission), or in P position (automatic transmission).

EMERGENCY INFORMATION

- 2 Place the wheel chock (1) as shown in the figure, then place the anti slip rubber pad (2) around the circumference of the tyre.
- 3 Fit the lashing straps (3) around the wheels and secure to the trailer. Tighten the straps until the car is securely held.

Tyre Repair and Wheel Replacement

Tool Identification

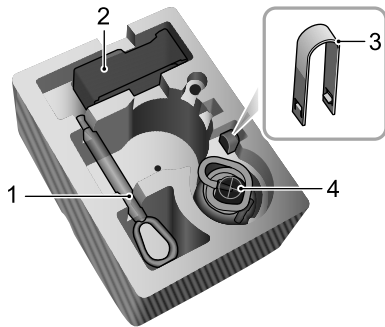

- 1 Towing Hook
- 2 Electric Air Pump
- 3 Wheel Bolt Cap Removal Tool
- 4 Repair Fluid Reservoir

Tyre Repair

- 1 Remove the label at the bottom of the repair fluid reservoir and attach it to the steering wheel to remind the driver not to exceed 50 mph (80 km/h).

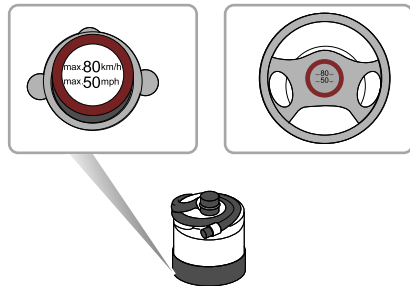

- 2 Connect the air hose of the electric air pump to the repair fluid reservoir, fit the tyre sealant bottle (upright) into the slot on the compressor. Remove the valve dust cap of the flat tyre, and connect the filler hose from the tyre sealant bottle to the tyre

EMERGENCY INFORMATION

valve. Ensure that the power switch of the electric air compressor is switched off (i.e., press "O"), then insert the plug from the compressor into the centre console power socket, and turn the START/STOP Switch to the position "ON/RUNNING".

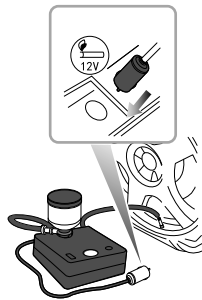

Note: To avoid battery discharge, it is recommended to keep the engine running.

- 3 Switch on the power switch of the electric compressor (i.e., press "-"), to start pumping sealant into the tyre. The tyre sealant bottle will become empty after approximately 30 seconds. The tyre should reach the specified pressure within 5 or 10 minutes.

Note: The pressure gauge may briefly reach 6 bar (87 psi), then the pressure begins to drop to normal.

- 4 When the required pressure is reached, switch off the power switch of the electric compressor (i.e., press "O").

Note: If the required pressure cannot be reached within 10 minutes, please disconnect the compressor, drive the vehicle 10 metres (33 feet) approx forward or backward to allow the sealant to spread within the tyre. If the required pressure can still not be reached, the tyre is severely damaged and you should seek assistance from the MG Authorised Repairer.

EMERGENCY INFORMATION

Note: Consecutive operation of Electric air compressor for more than 10 minutes may result in damage to the compressor.

Note: Under no circumstances should you continue your journey with a deflated tyre. Driving a vehicle with a deflated tyre is extremely dangerous.

- 5 Remove the tyre sealant bottle from the slot in the compressor, disconnect the hose from the tyre valve, remove the compressor plug from the centre console power socket, return the tyre repair kit to its stowage tray.
- 6 After successfully adding sealant to the tyre, drive immediately for a short time (around one minute) this will allow the sealant to distribute evenly inside the tyre. Continue driving and do not exceed 50 mph (80 km/h). After a further 10 minutes, find a safe place to stop and recheck the tyre pressure.

Please take different measures based on the tyre pressure measured:

- If the tyre pressure has dropped to less than 0.8 bar (11.6 psi), do not continue driving, seek assistance instead.
- If the tyre pressure is between 0.8 bar (11.6 psi) and specified pressure, connect the hose of electric air pump to the tyre valve, and connect the plug of the electric air pump to the power socket, then switch on the electric air pump to inflate the tyre until it reaches the specified pressure. Repeat the operations of step 6 after driving a maximum distance of 3 miles (5 km).



EMERGENCY INFORMATION

- If the tyre pressure has not dropped, you may continue driving, but the vehicle speed must not exceed 50 MPH (80 km/h), and the driving mileage must not exceed 125 miles (200 km).

Note: *DO NOT remove foreign objects (eg. screws,nails) from the tyre. The tyre repair system must only be used when the foreign object is in the tread pattern (A), DO NOT attempt a repair when the damage is in the sidewall of the tyre (B).*

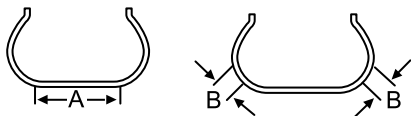

Changing a Wheel *

If you need to change the wheel during the journey, choose a safe place to stop away from the main road if possible. Always ask your passengers to get out of the car and wait in a safe area away from other traffic.

Switch on hazard warning lamps. If available, position a warning triangle about 50 to 150 metres behind your vehicle to warn approaching traffic.

Before changing a wheel, ensure the front wheels are in the straight ahead position. Apply the parking brake and place the gear shift lever of transmission in N position.

Observe the following precautions:

- Ensure the jack is positioned on firm, level ground.
- If the vehicle must be parked on the hill, place chocks in front of and behind other 3 wheels to prevent the vehicle moving.

Positioning the Jack



NEVER work beneath the car with the jack as the only means of support. The jack is designed for wheel changing only!

EMERGENCY INFORMATION



NEVER jack the car using any jacking points other than the jacking points. Serious damage to the car could result.

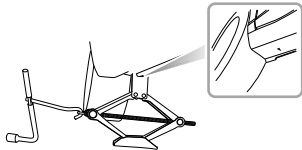
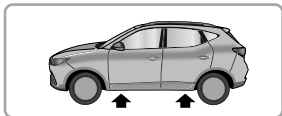

Avoid accidental contact with any underbody parts, especially hot exhaust system components.

Position the jack on firm level ground under the jacking point nearest the wheel to be removed. Note that the

domed head of the jack must fit into the corresponding recess in the sill plate (There is a triangle indicator in the area shown by the arrowhead. See the illustration above).

Turning the jack screw by hand, adjust the jack until the jack head fits snugly onto the sill in the correct area. Ensure that the base of the jack is in full contact with the level ground.

Fitting the Spare Wheel



Regularly check the spare wheel tyre pressure, it may not be used for long periods of time. After fitment, at the first opportunity check and adjust the tyre pressure.



The wheel bolts must be tightened to the specified torque after changing a wheel (120 ~ 130 Nm).

- Before raising the car, use the special tool supplied with the vehicle to remove each wheel bolt cap. Use the wheel bolt spanner to slacken each bolt half a turn anti-clockwise.

EMERGENCY INFORMATION

- 2 Turn the handle in a clockwise direction until the tyre is clear of the ground.
- 3 Remove the wheel bolts and place them in the tool tray to prevent them from being lost. Make sure the vehicle is steady and there is no risk of slip or movement before removing wheel bolts.
- 4 Remove the road wheel.

Note: *Avoid placing wheels face down on the ground - the surface may be scratched.*

- 5 Fit the spare wheel and tighten the wheel bolts with wheel bolt spanner until the wheel is seated firmly against the hub.
- 6 Lower the car and remove the jack, then FULLY tighten the wheel bolts in a diagonal sequence.
- 7 Finally, return the tools to the toolbox, put the toolbox into the well of the boot floor, tighten the spare wheel retaining nuts, and put the replaced wheel above the toolbox in the well in the load space floor (face down). Lower the boot floor, and put the boot storage box on the boot floor.

Note: *DO NOT stand on the handle of the wheel bolt spanner or use extension tube on the handle of the spanner.*

Note: *When replacing the wheel, please fully tighten the bolts in the diagonal sequence twice.*

Note: *Consult your MG Authorised Repairer or tyre specialist for a replacement tyre, as soon as possible.*

Spacesaver Spare Wheel



Only one spacesaver spare wheel can be used at any one time, otherwise the operational performance and brake performance may be reduced, thereby leading to accident or injury to yourself and others.



When driving on icy or slippery surfaces it is advised to fit the spacesaver wheel to the rear of the vehicle to maintain adequate stability. This may mean swapping a front wheel with a rear wheel.



Snow chains can not be used on the spacesaver spare wheel, this can cause damage to the car and snow chain.

When the spacesaver spare wheel is fitted, the vehicle speed should not exceed 50 mph(80 km/h). Please have the full-scale tyre repaired and replace the spare wheel as soon as possible. This will extend the life span of the spare wheel for other emergencies.

Note: DO NOT use an automatic car wash when the spacesaver wheel is fitted, the guide rails of the car wash may conflict with the wheel/tyre and cause damage.

EMERGENCY INFORMATION

Fuse Replacement

Fuse

Fuses are simple circuit breakers which protect the vehicle electrical equipment by preventing the electrical circuits from being overloaded. A blown fuse indicates that the item of electrical equipment it protects stops working.

Check a suspect fuse by removing it from the fuse box and looking for a break in the wire inside the fuse.

It is recommended to have spare fuses in the vehicle, which can be obtained from a local MG Authorised Repairer.

IMPORTANT

- NEVER attempt to repair a blown fuse. ALWAYS replace a fuse with one of the same rating.
- If a replaced fuse fails immediately, please contact an MG Authorised Repairer as soon as possible.

Fuse Box

There are two fuse boxes in the vehicle :

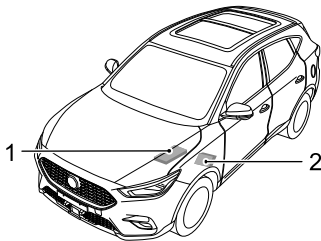

- 1 Front Compartment Fuse Box (at the left side of the Front Bay) .
- 2 Passenger Compartment Fuse Box (below the glove box at the front passenger side) .

EMERGENCY INFORMATION

Passenger Compartment Fuse Box

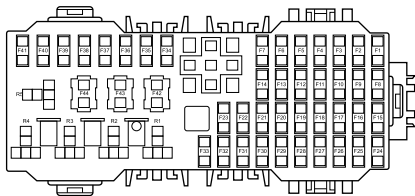

Check or Replace a Fuse

- 1 Switch off the vehicle power system and all electrical equipment, disconnect the battery negative cable.
- 2 Remove the closing panel below the glove box to gain access to the fuse box.

- 3 Press the fuse extraction tool onto the fuse head and pull to remove the fuse. A blown fuse can be recognised by a break in the wire.
- 4 Replace the blown fuse with a same rating.

Fuse Specification

NO.	Specs	Function
F1	15A	Front Washer Relay, Rear Washer Relay
F2	10A	Diagnostic Socket
F3	5A	PRND Display
F4	10A	Front Left Seat Heating Relay
F5	10A	Airbag ECU (SDM)
F6	10A	Keyless Start/Stop Switch, Gateway
F7	30A	Driver Seat Adjust Switch
F8	15A	Super Lock Relay

EMERGENCY INFORMATION

NO.	Specs	Function
F9-F11	-	-
F12	5A	Left Rear Driving Assistance Radar
F13-F14	-	-
F15	15A	Front Power Socket
F16	5A	Front Courtesy Lamp, Outside Mirror and Master Light Height Adjust Switch, Top USB, Left Headlamp Assembly, Right Headlamp Assembly
F17	5A	Rear USB
F18	5A	EPB Switch
F19	5A	Outside Mirror and Master Light Height Adjust Switch, Rain Light Sensor
F20	10A	Front Right Seat Heating Relay

NO.	Specs	Function
F21	10A	360° View Module, Passenger Compartment Fuse F12
F22	10A	Exterior Mirrors Heating Element
F23	25A	Rear Windscreen Heating Element
F24	20A	Front Central Display, Front Infotainment Control Module
F25	10A	Electronic Temperature Controller
F26	5A	Instrument Pack
F27	10A	Transmission Control Module-AT
F28	5A	Information Faceplate
F29	30A	Sunroof
F30	5A	DAB Module

EMERGENCY INFORMATION

NO.	Specs	Function
F31	5A	Tyre Pressure Monitoring System
F32	10A	Electronic Steering Column Lock
F33	30A	Sunroof
F34-F41	-	-
F42	25A	Stability Control Module(Valve)-MT
F42	40A	Stability Control Module(Valve)-AT
F43	30A	Passenger Window lift Switch, Rear Left Window Lift Switch
F44	30A	Driver Door Switch Pack, Driver Window Lifter, Rear Right Window Lift Switch

EMERGENCY INFORMATION

Front Compartment Fuse Box

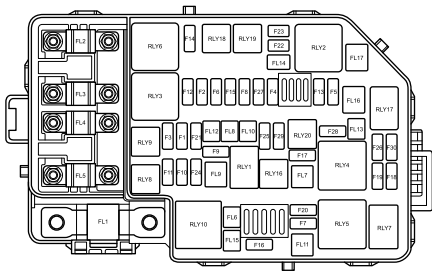

Check or Replace a Fuse

- 1 Switch off the vehicle power system and all electrical equipment, disconnect the battery negative cable.
- 2 Press the locating clips to remove the fuse box lid.
- 3 Press the fuse extraction tool onto the fuse head and pull to remove the fuse. A blown fuse can be recognized by a break in the wire.
- 4 Replace the fuse with a same rating.

Fuse Specification

NO.	Specs	Function
FL1	150A	Alternator
FL2	80A	Electric Power Steering Module
FL3	40A	Cooling Fan Relay Pack
FL4	80A	Windscreen/Mirror Heating Relay, Passenger Compartment Fuse F18, F19, F20, F21, F42, F43, F44

EMERGENCY INFORMATION

NO.	Specs	Function
FL5	80A	KLR Relay, Passenger Compartment Fuse F1, F2, F3, F4, F5, F6, F7, F8, F24, F25, F26, F27, F28, F29, F30, F31, F32, F33
FL6	-	-
FL7	40A	Electronic Temperature Controller, Blower
FL8	20A	Body Control Module
FL9	40A	Stability Control Module(Pump)
FL10	-	-
FL11	-	-
FL12	-	-
FL13	30A	Starter Relay
FL14	-	-

NO.	Specs	Function
FL15	-	-
FL16	30A	DC/DC Convertor
FL17	-	-
F1	10A	Right Headlamp Assembly
F2	15A	Downstream Lambda Sensor, Upstream Lambda Sensor, Positive Temperature Coefficient(1.5L), Intake Variable Camshaft Timing(1.0T), Exhaust Variable Camshaft Timing(1.0T), Oil Control Valve(1.0T), Canister Purge Valve(1.0T)
F3	10A	Left Headlamp Assembly
F4	10A	Compressor Relay
F5	5A	Engine Control Module
F6	10A	Fuel Injector(1.5L)

EMERGENCY INFORMATION

NO.	Specs	Function
F7	30A	Front Wiper Enable Relay, Front Wiper High/Low Speed Relay
F8	5A	Cooling Fan Relay Pack, Brake Pedal Switch, Fuel Pump Relay, AC Pressure Switch, Neutral Switch(1.5L)
F9	20A	Fuel Pump Relay
F10	10A	Right Headlamp Assembly
F11	10A	Left Headlamp Assembly
F12	30A	Ignition Coil, Engine Control Module
F13	15A	Horn Relay
F14	-	-

NO.	Specs	Function
F15	10A	Intake Variable Camshaft Timing(1.5L), Exhaust Variable Camshaft Timing(1.5L), Canister Purge Valve(1.5L), Electronic Thermostat(1.0T), Electronic Water Pump(1.0T), Dump Valve(1.0T), Waste Gate Control Valve(1.0T), Clutch Master Cylinder Sensor(1.0T)
F16	15A	Rear Wiper Relay
F17	10A	Fog Lamp Relay
F18	5A	Airbag ECU (SDM)
F19	5A	Instrument Pack, Front Detect Radar, Front View Control Module, Shifter Mechanism, Reverse Lamp Switch, DC/DC Convertor, Airbag Display Module
F20	5A	Engine Control Module

EMERGENCY INFORMATION

NO.	Specs	Function
F21	25A	Body Control Module
F22	-	-
F23	-	-
F24	-	-
F25	30A	Body Control Module
F26	-	-
F27	15A	Body Control Module
F28	-	-
F29	-	-
F30	5A	Engine Control Module

EMERGENCY INFORMATION

Bulb Replacement

Bulb Specification

Lamp Bulb	Specifications
Headlamp High/Low Beam	LED
Front Direction Indicators	LED
Daytime Running Lamps	LED
Front Side Light	LED
Front Fog Lamps *	H8 35W
Reverse Lamps	W16W 16W
Rear Direction Indicators	WY16W 16W

Lamp Bulb	Specifications
Rear Side Light	LED
Stop Lamps	LED
License Plate Lamps	W5W 5W
Rear Fog Lamps	LED
High Mounted Stop Lamp	LED
Interior Lamp	W5W 5W
Load Space Lamp	C10W 10W

Bulb Replacement

Before replacing any bulb, turn off the lighting switch to avoid any possibility of a short circuit.

Note: *MG only recommends replacement bulbs that completely meet the manufacturers specifications.*

Take care NOT to touch the glass with your fingers; always use a cloth to handle the bulb. If necessary, clean the glass with methylated spirits to remove fingerprints.

If in doubt, when replacing bulbs, contact an MG Authorised Repairer.

For replacement of other bulbs not listed please consult an MG Authorised Repairer.

Front Fog Lamps Bulb Renewal

- 1 Disconnect the battery negative terminal.
- 2 For front fog lamps bulb replacement, it is necessary to remove the front bumper cover, seek guidance from an Authorised MG Repairer.
- 3 Remove the wiring connector from the bulb.
- 4 Rotate the bulb anti-clockwise and remove.

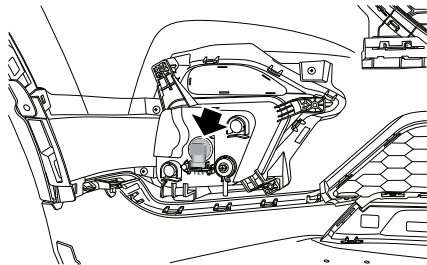

EMERGENCY INFORMATION

- 5 Locate the bulb in the lamp, rotate clockwise until fully secured.
- 6 Refit the wiring connector to the new bulb.
- 7 Fit the front bumper cover.
- 8 Connect the negative battery terminal.
- 9 Test lamp operation.

Reverse Lamps Bulb Renewal

- 1 Open the tailgate.
- 2 Disconnect the battery negative terminal.
- 3 Using a suitable pry bar or lever, carefully remove the cover trim.
- 4 Using a suitable spanner/socket wrench, remove the 3 screws (1) securing the lamp to the tailgate. Remove the wiring connector (2). Release the lamp assembly and remove away from the body.

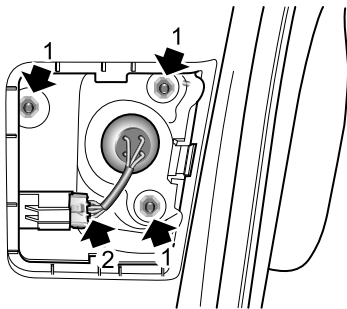

5 Rotate the bulb holder in an anti-clockwise direction.

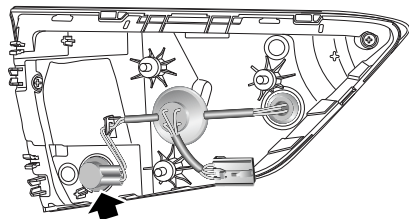

- 6 Remove bulb holder and remove bulb.
- 7 Fit new bulb to bulb holder.
- 8 Insert bulb holder in lamp assembly, rotate clockwise until fully secure.
- 9 Ensure lamp seal is correctly located.
- 10 Position lamp to tailgate, refit the wiring connector and the screw fixings, and tighten to 2.7-3.3 Nm.

EMERGENCY INFORMATION

- 11 Refit screw cover trim.
- 12 Reconnect battery negative terminal.
- 13 Test lamp operation.
- 14 Close tailgate.

License Plate Lamps Bulb Renewal

- 1 Disconnect the battery negative terminal.
- 2 For license plate lamps bulb replacement, it is necessary to remove the rear bumper cover, seek guidance from an Authorised MG Repairer.
- 3 Remove the wiring connector.
- 4 Rotate the bulb holder in an anti-clockwise direction.

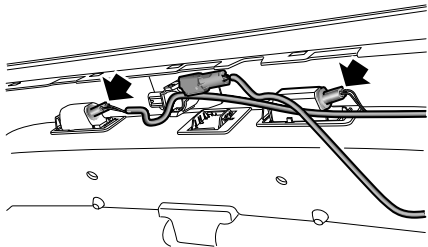

EMERGENCY INFORMATION

- 5 Remove bulb holder and remove bulb.
- 6 Fit new bulb to bulb holder.
- 7 Insert bulb holder in lamp assembly, rotate clockwise until fully secure.
- 8 Refit the wiring connector.
- 9 Fit the rear bumper cover.
- 10 Reconnect battery negative terminal.
- 11 Test lamp operation.

Rear Direction Indicator Bulb Renewal

- 1 Open the tailgate.
- 2 Disconnect the battery negative terminal.
- 3 Using a suitable pry bar or lever, carefully release and remove the securing screw cover trim.
- 4 Using a suitable spanner/socket wrench, remove the 2 screws securing the lamp to the body.

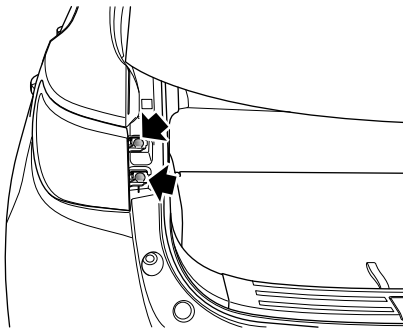

EMERGENCY INFORMATION

- 5 Remove the wiring connector. Release the lamp assembly and remove away from the body.
- 6 Rotate the bulb holder in an anti-clockwise direction.

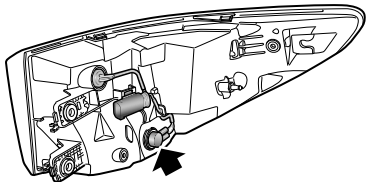

- 7 Remove bulb holder and remove bulb.
- 8 Fit new bulb to bulb holder.
- 9 Insert bulb holder in lamp assembly, rotate clockwise until fully secure.

- 10 Ensure lamp seal is correctly located.
- 11 Position lamp to body, refit the wiring connector, start both screw fixings, and tighten to 3-5 Nm.
- 12 Refit screw cover trim.
- 13 Reconnect battery negative terminal.
- 14 Test lamp operation.
- 15 Close tailgate.

Interior Lamp Bulb Renewal

- 1 Disconnect the battery negative terminal.
- 2 Use a suitable tool or small flat bladed screwdriver to gently prise front end of the lens, and remove the lens.

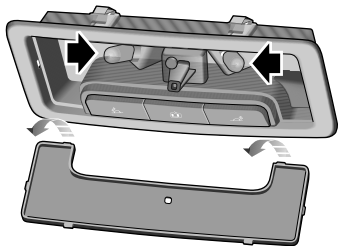

- 3 Pull the bulb from its mounting to remove.
- 4 Install new bulb.
- 5 Install the lens, locate the two prongs at the front of the lens and then carefully flex the lens to locate the two prongs at the rear of the lens into the lamp

assembly. Push the lens upwards until it 'clicks' into position

- 6 Connect battery negative terminal.
- 7 Test lamp operation.

EMERGENCY INFORMATION

Load Space Lamp Bulb Renewal

- 1 Open the tailgate.
- 2 Disconnect the battery negative terminal.
- 3 Insert a suitable tool or small flat bladed screwdriver into the indent on one of the narrow sides of the lens and carefully remove the unit from its location.

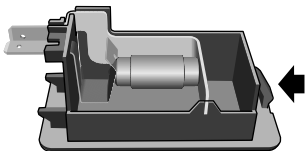

- 4 Pull the bulb from its mounting to remove.
- 5 Install new bulb.
- 6 Refit the unit, push until fully secured.
- 7 Connect battery negative terminal.
- 8 Test lamp operation.
- 9 Close tailgate.

Maintenance

260 Maintenance

264 Bonnet

266 Engine Compartment

268 Engine

270 Cooling System

272 Brake

274 Battery

276 Washers

278 Wipers

281 Tyres

287 Cleaning and Vehicle Care

MAINTENANCE

Maintenance

Routine Maintenance

The safety, reliability and performance of your car will depend partly on how well it is maintained. You must ensure that maintenance is carried out when required and according to the information contained in the 'Service Schedule'.

Servicing

For next service information, please refer to "Message Centre" in "Instruments and Controls" chapter or information related to entertainment system. After the completion of each service, the next service display will be reset by your MG Authorised Repairer.

Note: If a service is not carried out (or the display is not reset by the local MG Authorised Repairer after service), the service display cannot provide correct information.

Service History

Ensure your local MG Authorised Repairer fills in the Service Records after each service.

Brake Fluid Replacement

Replace the brake fluid according to the information contained in the "Service Schedule".

Note: Brake fluid replacement will be an additional cost.

Coolant Replacement

Replace the engine coolant (mixed solution of antifreeze and water) according to the information contained in the "Service Schedule".

Note: Coolant replacement will be an additional cost.

Emission Control

Your car is fitted with emission and evaporative control equipment designed to meet specific territorial and legal requirements. Incorrect engine settings may adversely affect exhaust emissions, engine performance and fuel

consumption, as well as causing high temperatures, which could result in damage to the catalytic converters and engine.

IMPORTANT

You should be aware that unauthorised replacement, modification or tampering with this equipment by an owner or motor vehicle repairer could result in the manufacturer's warranty being deemed as invalid. In addition, engine settings must not be tampered with.

Owner Maintenance



Any significant or sudden drop in fluid levels, or uneven tyre wear, should be reported without delay. For further information, refer to an MG Authorised Repairer.

In addition to the routine services referred to previously, a number of simple checks must be carried out more frequently. You can carry out these checks yourself and advice is given on the pages that follow.

Daily Checks

- Operation of lights, horn, direction indicators, wipers, washers and warning lights.
- Operation of seat belts and brakes.
- Look for fluid deposits underneath the car that might indicate a leak.
- Check tyre appearance.

Weekly Check

- Engine oil level.
- Coolant level.
- Brake fluid level.
- Windscreen washer fluid level.
- Operate air conditioning.

Note: The engine oil level should be checked more frequently if the car is driven for prolonged periods at high speeds.

Special Operating Conditions

If your car is frequently used in dusty conditions, or operated in extreme climates where sub-zero or very high ambient temperatures are normal, more frequent attention may need to be paid to servicing requirements.

MAINTENANCE

You need to carry out special maintenance operations (refer to Service Portfolio or contact your MG Authorised Repairer).

Safety in the Garage



Cooling fans may commence operating after the engine is switched off, and continue operating for a number of minutes. Keep clear of all fans while working in the engine compartment.

If you need to carry out maintenance, observe the following safety precautions at all times:

- Keep your hands and clothing away from drive belts and pulleys.
- If the car has been driven recently, **DO NOT TOUCH** exhaust and cooling system components until the engine has cooled.
- **DO NOT TOUCH** electrical leads or components while the engine is running, or with the ignition switch on.

- **NEVER** leave the engine running in an unventilated area - exhaust gases are poisonous and extremely dangerous.
- **DO NOT** work underneath the car with a wheel changing jack as the only means of support.
- Ensure that sparks and naked lights are far away from the engine compartment.
- Wear protective clothing and work gloves.
- Remove watches and jewelry before working in the engine compartment.
- **DO NOT** allow tools or metal parts of the car to make contact with the battery leads or terminals.

Toxic Liquid

Fluids used in motor vehicles are poisonous and should not be consumed or brought into contact with open wounds. These include: battery acid, coolant, brake fluid, power steering fluid, fuel, engine oil and windscreen washer additives.

For your own safety, **ALWAYS** read and observe all instructions printed on labels and containers.

Used Engine Oil

Prolonged contact with engine oil may cause serious skin disorders, including dermatitis and cancer of the skin. Wash thoroughly after contact. Used engine oil should be disposed of correctly. Incorrect disposal can cause a threat to the environment.

MAINTENANCE

Bonnet

Opening the Bonnet



DO NOT drive when the bonnet is not closed or retained only by the safety catch.

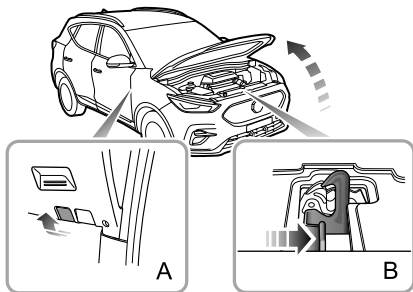

- 1 From the inside of the vehicle, pull the bonnet release handle (Figure A).
- 2 Move the safety catch release handle on the bonnet lock assembly in the direction of the arrow (Figure B) to release the bonnet safety catch.
- 3 Raise the bonnet and hold it up with the support rod firmly.

Closing the Bonnet

Support the bonnet by one hand, release the support rod using the other hand, and place it firmly into the support rod base. Then hold the bonnet using both hands and lower it, allowing it to drop for the last 20 cm ~ 30 cm to fully close the bonnet.

By attempting to lift the front edge of the bonnet, check if the lock is fully engaged after closing the bonnet. If it is not fully engaged, you must repeat the operation.

Bonnet Open Warning

If the bonnet is not fully engaged, when the vehicle power system is in the ON/RUNNING position, the

corresponding alarm icon will be displayed in the information message centre of the instrument pack. If it is detected that the bonnet is not fully engaged whilst driving, an audible warning will sound.

IMPORTANT

- For safety reasons, the bonnet should be fully latched and secure when driving. Therefore every time the bonnet is opened, you must check after closing that the bonnet is securely latched, e.g. the bonnet edge is flush with the body of the car.
- You should stop the car immediately when safety permits and close the bonnet if it is not closed fully when driving.
- Ensure the bonnet is supported manually when removing the bonnet support rod, failure to support the panel will result in the panel falling down causing injury or vehicle damage.
- Beware of injury to hands while fully closing the bonnet with a downward force.

MAINTENANCE

Engine Compartment

1.5L Engine Compartment



While working in the engine compartment, always observe the safety precautions listed under 'Safety in the Garage', refer to 'Maintenance' in 'Maintenance' section.

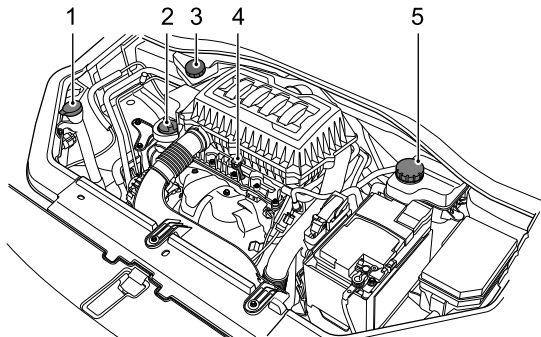

- 1 Washer fluid reservoir (blue cap)
- 2 Engine oil filler cap (black cap)
- 3 Brake fluid reservoir (yellow cap)
- 4 Engine oil dipstick (yellow)
- 5 Coolant reservoir (black cap)

I.0L Turbocharged Engine Compartment



While working in the engine compartment, always observe the safety precautions listed under 'Safety in the Garage', refer to 'Maintenance' in 'Maintenance' section.

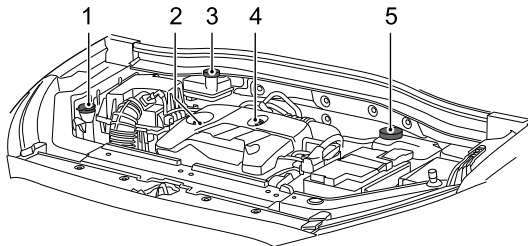

- 1 Washer fluid reservoir (blue cap)
- 2 Engine oil filler cap (black cap)
- 3 Brake fluid reservoir (yellow cap)
- 4 Engine oil dipstick (yellow)
- 5 Coolant reservoir (black cap)

MAINTENANCE

Engine

Engine Oil

ACEA Classification of Engine Oils

European Automobile Manufacturers Association (ACEA) will classify the engine oils based on performance and quality. To ensure the best performance of the vehicle, please only use engine oils that are recommended by the manufacturer (see "Technical Data" - 'Recommended Fluids and Capacities'.

If you are operating the vehicle in extreme temperature conditions please consult your MG Authorised Repairer for advice.

Engine Oil Level Check and Top Up



Driving the vehicle with the engine oil level ABOVE the upper mark, or BELOW the lower mark on the dipstick, will damage the engine. Take care to avoid spilling engine oil onto a hot engine – a fire may result!

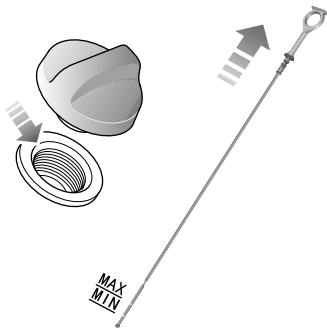

1.5 L Engine

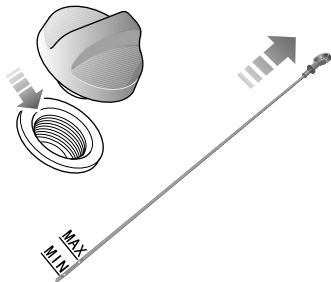

1.0 T Engine

Check the oil level weekly and top up with oil when necessary. Ideally, the oil level should be checked with the engine cold and the car resting on level ground. However, if the engine is running and already getting warm, wait for at least five minutes after switching off the START/STOP Switch before checking the level.

- 1 Withdraw the dipstick and wipe the blade clean.

- 2 Slowly insert the oil dipstick and pull it out again to check the oil level; the oil level shall not be lower than the "MIN" mark on the oil dipstick.
- 3 Clean off any debris that may have collected around the oil filler cap area. Unscrew the oil filler cap and refill the oil to maintain the oil level between the "MAX" mark and "MIN" mark on the oil dipstick.
- 4 Wait for 5 minutes and then recheck the oil level, adding more oil if necessary – **DO NOT OVERFILL!**
- 5 Finally, ensure the dipstick and filler cap are replaced.

Engine Oil Specification

Use the engine oil recommended and certified by the manufacturer. Refer to "Recommended Fluids and Capacities" in "Technical Data" section.

Note: *DO NOT use any oil additives.*

IMPORTANT

Check the engine oil more frequently if the vehicle is driven at high speeds for prolonged periods.

MAINTENANCE

Cooling System

Coolant Check and Top Up



DO NOT remove the engine coolant reservoir cap when the cooling system is hot - escaping steam or hot coolant could cause serious injury.

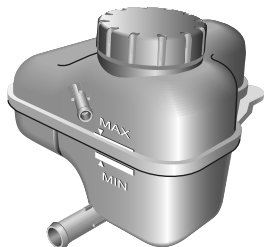

It is recommended that the cooling system should be checked weekly when the cooling system is cold and with the car resting on level ground. If the level is below the 'MIN' mark, remove the expansion tank cap and top up coolant, the level must not be higher than 'MAX' mark.

Note: Prevent coolant coming into contact with the vehicle body when topping up. Coolant will damage paint.

If the coolant level falls appreciably during a short period, the cooling system leakage may occur, please have it serviced in time by a local MG Authorised Repairer.

Coolant Specification

Please use the coolant recommended and certified by the manufacturer. Refer to 'Recommended Fluids and Capacities' in "Technical Data" chapter.

Note: In an emergency, top up the coolant reservoir with a small amount of clean water. However, it should be noted that this will weaken the anti-freeze and anti-corrosion protection and reduce the service life

of the coolant. **DO NOT** refill the cooling system with anti-freeze of different formulations.

Note: The addition of corrosion inhibitors or other additives to the cooling system of this car may severely disrupt the efficiency of the system and cause engine damage. For cooling system issues please consult an MG Authorised Repairer.

Antifreeze Fluid



Coolant is poisonous and can be fatal if swallowed - keep coolant containers sealed and out of the reach of children. If accidental contact of coolant by children is suspected, seek medical assistance immediately.



Prevent coolant coming into contact with the skin or eyes. If this occurs, rinse immediately with plenty of water. If eyes are still red, painful or uncomfortable, seek medical attention immediately.

MAINTENANCE

Brake

Brake Pads



DO NOT rest your foot on the brake pedal while driving; this may overheat the brakes, reduce their efficiency and cause excessive wear.

For the first 900 miles (1500 km), you should avoid situations where heavy braking is required.

Remember that regular servicing is vital to ensure that all the brake components are examined for wear at the correct intervals, and replaced when required to ensure long term safety and optimum performance during the interval prescribed in Service Portfolio.

The car needs to run in for 500 miles (800 km) after the brake pad or disc is replaced.

Brake Fluid Check and Top Up



Brake fluid is highly toxic, keep containers sealed and out of the reach of children. If accidental contact of brake fluid is suspected, seek medical attention immediately.



Prevent brake fluid coming into contact with the skin or eyes. If this occurs, rinse immediately with plenty of water. If eyes are still red, painful or uncomfortable, seek medical attention immediately.

The brake fluid level should be checked weekly when the system is cold and with the car on level ground.

The fluid level can be seen through the reservoir neck and should be maintained as close to the "MAX" mark as possible. Do not allow the level to drop below the "MIN" mark.

Note: Brake fluid will damage painted surfaces. If you accidentally spill the brake fluid on the painted surface, soak up any spillage with an absorbent cloth

immediately and wash the area with water or car shampoo.

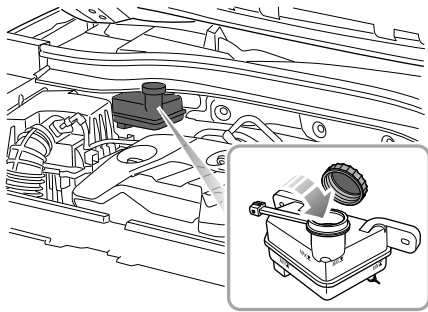

IMPORTANT

Replace brake fluid regularly according to the Service Portfolio.

Brake Fluid Specification

Use the brake fluid recommended and approved by the manufacturer. Refer to "Recommended Fluids and Capacities" in the "Technical Data" section.

MAINTENANCE

Battery

Battery Maintenance



DO NOT leave electric components switched on when the engine is not running, the battery may become flat and you will not be able to start the engine.

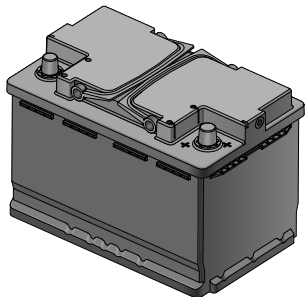

You can see the battery when you open the engine compartment. The battery is maintenance-free type, therefore there is no need to refill fluid.

Note: *If the vehicle is stored for more than 1 month, remove the negative terminal from the battery. Make sure that the START/STOP switch has been turned off before connecting or disconnecting the negative terminal. When connecting the negative terminal again, the vehicle must be left in a locked state for 4 hours to re-calibrate the battery condition. Failure to adhere to this will inhibit the stop/start functionality.*

Battery Replacement



The battery contains sulphuric acid, which is corrosive.

The battery contains sulphuric acid, which is corrosive. Please go to an MG Authorised Repairer to remove and install the battery. Only fit a replacement battery of the same type and specification as the original to maintain the correct vehicle functionality.



The battery must be disposed of using an approved method, used batteries can be harmful to the environment. It should be recycled by a professional company. Please consult an MG Authorised Repairer for more details.

MAINTENANCE

Washers

Windscreen Washer Check and Top Up



When filling the washer fluid, DO NOT let the washer fluid spill on parts in the compartment or on the paint surface of vehicle body. In case the washer fluid is spilled on hands or other parts of the body, please immediately wash with clean water.

Check the washer fluid level regularly. When the level of washer fluid is low, please top up the washer fluid as instructed.

Note: *DO NOT use anti-freeze or vinegar/water solution in the washer reservoir - anti-freeze will damage paintwork while vinegar will damage the washer pump.*

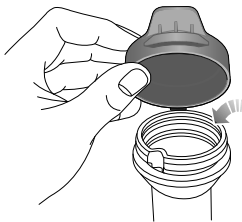

IMPORTANT

- Use the washer fluid recommended and certified by the manufacturer. Misuse of washer fluid in winter may cause damage to the washer pump due to freezing.
- Using the washers when there is no washer fluid may cause damage to the washer pump.
- Operating the wipers when the windshields are dry and there is no washer fluid may cause damage to the windshields and wipers. Please spray the washer fluid and start the wipers when there is adequate washer fluid.

Washer Nozzles

Operate the washers periodically to check that the nozzles are clear and properly directed.

If the nozzle is obstructed, insert a needle or thin metal wire into the hole to remove the obstruction.

Washer Fluid Specification

Use the washer fluid recommended and certified by the manufacturer. Refer to 'Recommended Fluids and Capacities'.

MAINTENANCE

Wipers

Wiper Blades

IMPORTANT

- Grease, silicon and petrol based products impair the blade's wiping capability. Wash the wiper blades in warm soapy water and periodically check their condition.
- Clean the windscreen frequently, **DO NOT** use wipers to remove stubborn or ingrained dirt, it will reduce their effect and their life span.
- If signs of hardness or cracking in the rubber are found, or if the wipers leave streaks or unwiped areas on the screen, then the wiper blades should be replaced.
- Clean the windscreen regularly with an approved glass cleaner and ensure the screen is thoroughly cleaned before fitting replacement wiper blades.
- Only fit replacement wiper blades that are identical to the original specification.
- Clean ice and snow from around wipers and ensure they are not frozen or otherwise sticking to the windscreen before attempting to operate them.

Replacing Front Wiper Blades

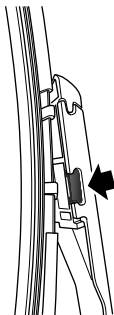

- 1 With the bonnet closed, and within 20 seconds of switching the vehicle power system to the OFF position, operate the wiper stalk switch by pressing down and releasing, the wipers will sweep and stop in the 'service position' on the windscreen.
- 2 Lift the wiper arm away from the windscreen.
- 3 Press the retaining clips at both sides (as shown in the figure), whilst pulling the wiper blade outward, to remove the wiper blade from the wiper arm and discard.
- 4 Position the fitting of the new wiper blade into the slot of the wiper arm.
- 5 Push the wiper blade towards the wiper arm until it is located embedded with a click been heard.
- 6 Place the wiper assembly back on the windscreen.
- 7 To exit the service mode and return the wipers to the park position, operate the wiper stalk switch again by pressing down and releasing, alternatively, switch the vehicle power system to the ON position.

MAINTENANCE

Replacing Rear Wiper Blades

4 Place the wiper assembly back on the rear window.

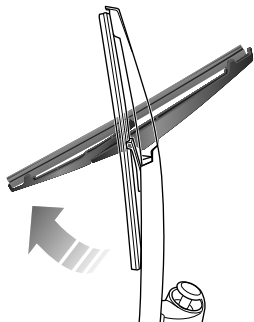

- 1 Lift the wiper arm away from the rear window.
- 2 Rotate the wiper blade as shown in the figure, to remove it from the wiper arm and discard.
- 3 Position the fitting of the new wiper blade into the slot of the wiper arm. Ensure the wiper blade is properly secured on the wiper arm.

Tyres

Overview

- Take extra care when using new tyres for the first 300 miles (500 kilometres).
- Avoid excessive cornering at speed.
- Slow down when passing through road shoulder or a similar section, and allow the wheels to go through the shoulder at the right angle as far as possible.
- Regularly check the damage of tyres (stabs, scratches, cracks and pits) and remove any foreign objects from the tread.
- Prevent the tyre from contacting oil, grease and fuel.
- Ensure valve caps are always fitted.
- If the tyre is to be removed always mark the tyre/wheel orientation to ensure correct reinstallation.
- The wheels or tyres that have been disassembled should be kept in a cool, dry and light-free place.

New Tyres

New tyres may not have the best adhesive ability at the beginning. Therefore, driving your vehicle at moderate

speed and in a prudent way at the first 300 miles (500 kilometres), which is also beneficial to the service life of the tyres.

The damage of tyre or rim may happen unnoticed. If abnormal vibration or handling is experienced, that means the tyre or rim may have been damaged. Please slow down and park your vehicle in absolute safety, then check the tyre and rim. If you can't see the damage from the outside, you should continue to drive with low speed and go to the nearest MG Authorised Repairer for inspection.

Directional Tyres

Directional tyres are marked with 'direction of rotation' (DOR). To maintain handling characteristics, tyre performance, low road noise and extend tyre life, tyres must always be fitted with indication arrow showing the correct 'DOR'.

Tyre Life

Correct tyre pressure and moderate driving style can extend tyre life.

Recommendations:

MAINTENANCE

- If the vehicle is to be stored for a lengthy time, please move your vehicle at least once in two weeks to 'rotate the tyres'.
- Check the pressure of tyres regularly when they are cold.
- Avoid cornering at excessive speed.
- Regularly check tyres for abnormal wear patterns.

These following factors may affect the tyre life.

Tyre Pressure

Incorrect pressure will cause the abnormal wear of the tyre, greatly shorten the service life, and have an adverse effect on the driving characteristics of the vehicle. Tyre pressure should be checked at least once a month, and once prior to each long-distance journey.

Driving Style

Excessively harsh acceleration and braking (you may hear a piercing noise) or driving at high speed whilst cornering will increase the wear of tyre.

Wheel Balance

The working balance of auto-wheels is well tested before a new vehicle comes out of the factory. But the wheels may be out of balance due to many factors.

If wheels are out of balance, shaking or vibration of the steering mechanism may occur and the tyres may be excessively worn. It is important to rectify this quickly. Each wheel should be rebalanced after installing a new tyre or having the tyre repair.

Wheel Alignment

Incorrect wheel alignment can cause excessive tyre wear and affect vehicle safety. If the tyres show signs of abnormal wear, seek advice from an MG Authorised Repairer.

Caring for Your Tyres



DEFECTIVE TYRES ARE DANGEROUS!
DO NOT drive if any tyre is damaged, is excessively worn, or is inflated to an incorrect pressure.

Always drive with consideration for the condition of the tyres, and regularly inspect the tread and side walls for any sign of distortion (bulges), cuts or wear.

Note: *If possible, protect tyres from contamination by oil, grease and fuel.*

Tyre Pressure



Before a long distance journey, the tyre pressure must be checked.

Check the pressure (including the spare wheel) at least once a month, when the tyres are cold.

If it is necessary to check the tyre pressure when they are warm, you should expect the pressure to have increased by 0.3 to 0.4 bar (4.35 to 5.8 psi). In this circumstance, NEVER let air out of the tyres in order to match the recommended pressure (cold).

Valves

Keep the valve caps screwed down firmly - they prevent dirt from entering the valve. Check the valve for leaks (listen for a tell-tale hissing) when you check the tyre pressure.

Punctured Tyres

If a sharp object penetrates the tyre and remains in it, the tyre may not leak. If you are aware of this occurring, reduce speed immediately and drive with caution until the spare wheel can be fitted, or repairs undertaken.

Note: *If the sidewall of the tyre is damaged or distorted, replace the tyre immediately, do not attempt a repair.*

Tyre Wear Indicators

At the bottom of the original tyre, there is a 1.6 millimeter high wear mark perpendicular to the wheel rolling direction. These indicators moulded into the tread pattern at several points around the circumference. A mark on the side of a tyre, such as the upper case letter TWI or the triangle, indicating the position of the wear mark.

When the tread has worn down to 1.6 millimeter, the indicators will come to the surface of the tread pattern, producing the effect of a continuous band of rubber across the width of the tyre.

MAINTENANCE

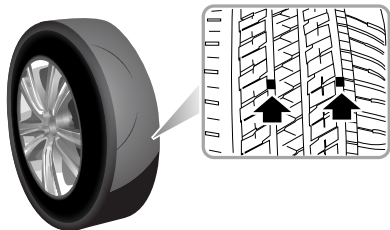

IMPORTANT

A tyre **MUST** be replaced as soon as a wear indicator becomes visible.

Replacement Tyres



*It is recommended to install the tyres consistent with the original specifications. **DO NOT** replace the tyres with tyres of any other type. Alternative tyres, of a different specification, may adversely affect the vehicle's driving characteristics and safety. In order to make your driving and safety better guarantee, it is suggested that you consult an **MG Authorised Repairer**.*

Always have replacement wheels and tyres balanced before use.

Wheel Fitment Rotation

It is not recommended that you swap wheels from side to side or front to rear in order to equalise tyre wear. Your vehicle is fitted with Tyre Pressure Monitoring System which means that each wheel is programmed to the relative position.

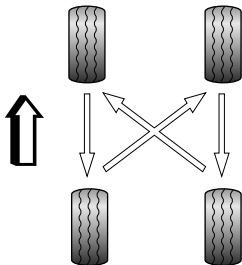

If you do wish to swap wheels and tyres around on the vehicle please consult an MG Authorised Repairer as extra coding will be required.

Snow Chains

Unsuitable snow chains could damage the tyres, wheels, suspension, brakes or bodywork of your car.

Please pay attention to the following requirements in the usage:

- The tyre/snow chains can only be fitted on the front wheels;
- The thickness of tyre/snow chains shall not exceed 15 mm;
- Please always observe the installation and tension instructions for the tyre/snow chains, as well as the speed limitations of different roads;
- DO NOT drive faster than 30 mph (50 km/h) ;
- To avoid the tyre damage and excessive wear of the tyre/snow chains, the tyre/snow chains must be removed while driving on the road without snow.

The wheel and tyre specifications for the tyre/snow chains apply to this model are as follows:

Wheel rim size: 6.5J×16

Tyre size: 205/60 R16

Note: *Snow chains are only allowed to be fitted to tyres of the specifications recommended by the manufacturer.*

MAINTENANCE

Note: If you drive on roads covered with snow or ice, it is recommended to use winter tyres. Consult an MG Authorised Repairer for details.

Cleaning and Vehicle Care



Observe all safety precautions on cleaning products; do not drink fluids and keep them away from the eyes.

External Car

Washing Your Car



Some high pressure cleaning systems will penetrate door, window and sunroof seals, and damage lock mechanisms. DO NOT aim water jets directly at components that might be easily damaged.



Do not clean the engine compartment with high pressure water since it may damage the electrical system of the vehicle.

In order to preserve the paint finish on your car, please observe the following care points:

- DO NOT use hot water to wash the car.
- DO NOT use detergents or washing up liquid.
- In hot weather, DO NOT wash the car in direct sunlight.

- When using a hose, DO NOT aim the water directly at window, door or sunroof seals, or through wheel apertures onto the brake components.

If the car is particularly dirty, use a hose to flush grime and grit from the bodywork, prior to washing. Then, wash the car using cold or lukewarm water containing a good quality wash and wax shampoo. Always use plenty of water to ensure that grit is flushed from the surface and not ground into the paintwork. After washing, rinse the bodywork with clean water and dry off with a chamois leather.

Cleaning the underside

Note: DO NOT use a high pressure hose to clean the engine compartment – damage to the car's electronic systems may occur.

From time to time, but particularly during winter months when salt has been used on the roads, use a hose to wash the underside of the car. Flush away accumulations of mud and thoroughly clean those areas where debris can easily collect (wheel arches and panel seams, for example).

MAINTENANCE

IMPORTANT

- Avoid cleaning the vehicle in direct sunlight.
- When cleaning the vehicle in winter avoid spraying water directly onto door locks and panel gaps due to risk of icing.
- Do not use rough sponges or cloth to clean the car, this will damage the paintwork finish.
- When cleaning the headlamps do not use a dry cloth or sponge, use only warm soapy water.

Cleaning with a High Pressure Cleaner

Note: *Always read the manufacturers operating instructions.*

When using high pressure washers, always ensure there is adequate distance between the spray nozzle and any soft materials, decals or rubber seals.

IMPORTANT

- Please pay attention to the operating instructions of high pressure cleaner.
- Soft parts on the vehicle should be kept in a large enough distance from the high pressure cleaner.

Removing tar spots

Use white spirit to remove tar spots and stubborn grease stains from the paintwork. Then wash the area immediately with soapy water to remove all traces of the spirit.

Body Protection

After washing, examine the paintwork for damage. If the damage has revealed bare metal, use a colored primer first, then apply the correct colour base coat and finish off with a lacquer pencil, if appropriate. Carry out this treatment after washing but before polishing or waxing. More extensive damage to paint or bodywork must be repaired in accordance with the manufacturer's recommendations. Failure to do this will invalidate the Anti-Corrosion Warranty. If in doubt, ask your MG Authorised Repairer.

Polishing the Paintwork



DO NOT use car polish containing coarse abrasives – these will remove the paint film and damage the gloss finish.

Occasionally treat the paint surface with an approved polish containing the following properties:

- Very mild abrasives to remove surface contamination without removing or damaging the paint.
- Filling compounds that will fill scratches and reduce their visibility.
- Wax to provide a protective coating between the paint and the elements.

Note: If possible, avoid applying polish or wax products to window glass and rubber seals.

Wiper Blades

Wash in warm soapy water. DO NOT use spirit or petrol based cleaners.

Windows and Mirrors

Regularly clean all windows, inside and out, using an approved glass cleaner.

Windscreen:In particular, clean the outside of the screen with glass cleaner after washing the car with wash and wax products, and before fitting new wiper blades.

Rear screen:Clean the inside with a soft cloth, using a side to side motion to avoid damaging the heating elements.

Note: DO NOT scrape or use abrasive cleaners on the inside of the rear screen – this will damage the heating elements.

Mirrors:Wash with soapy water. Use a plastic scraper to remove ice. DO NOT use abrasive cleaning compounds or metal scraper.

Plastic Components

Any plastic components should be cleaned using conventional cleaning methods and not be treated with abrasive materials.

MAINTENANCE

Paint Damage

Any paint damage or stonechips should be treated with suitable paint/lacquer materials immediately to avoid invalidating the Anti Corrosion Warranty.

Weather Strips and Rubber Seals

Any weather strips or rubber aperture seals should be treated with suitable materials (silica gel) if they are cleaned using strong detergents, this should avoid any sticking and maintain the service life of the seal.

Wheels



When cleaning the wheels any materials or water that contact the brake disc directly may effect braking efficiency.

In order to ensure the wheels are kept in optimum condition they should be cleaned regularly.

Only use a recommended non-acidic propriety wheel cleaner. Always read the instructions on the product.

Cleaning the Interior

Plastic materials

Clean plastic-faced materials with diluted upholstery cleaner, then wipe with a damp cloth.

Note: DO NOT polish dashboard components – these should remain non-reflective.

Carpet and fabrics

Clean with diluted upholstery cleaner - test a concealed area first.

Leather

Clean leather trim with warm water and a non-detergent soap. Dry and polish the leather with a dry, clean, lint-free cloth.

Note: DO NOT use petrol, detergents, furniture creams or polishes as cleaning agents.

Instrument Pack, Audio and Navigation Display

Clean with a dry cloth only. DO NOT use cleaning fluids or sprays.

Airbag Module Covers



DO NOT allow these areas to be flooded with liquid and DO NOT use petrol, detergent, furniture cream or polishes.

To protect damage to the airbag SRS, the following areas should be cleaned sparingly with a damp cloth and upholstery cleaner ONLY:

- Steering wheel centre pad.
- Area of dashboard containing the passenger airbag.
- Area of roof lining and front pillar finishers which enclose the side head impact protection modules.

Seat Belts



DO NOT use bleaches, dyes or cleaning solvents on seat belts.

Extend the belts, then use warm water and a non-detergent soap to clean. Allow the belts to dry naturally; DO NOT retract them or use the car until they are completely dry.

Technical Data

- 294 Technical Data Dimensions*
- 296 Weights*
- 299 Major Parameters of Engine*
- 301 Recommended Fluids and Capacities*
- 302 Wheel Alignment (Unladen Condition)*
- 302 Wheels and Tyres*
- 302 Tyre Pressure (Cold)*

TECHNICAL DATA

Technical Data Dimensions

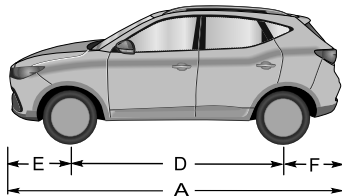
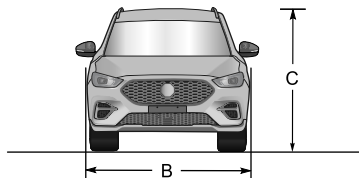

Item, Units	Parameter
Overall length A, mm	4323
Overall width B, mm	1809
Overall height C (unladen), mm	1628(excluding luggage rack)/1653(including luggage rack)
Wheelbase D, mm	2585
Front Overhang E, mm	901
Rear Overhang F, mm	837
Front wheel track, mm	1521

TECHNICAL DATA

Item, Units	Parameter
Rear wheel track, mm	1523
Minimum ground clearance (laden), mm	154
Minimum turning circle diameter, m	11.2
Fuel tank capacity, l	45

Note: Vehicle length measurement, including all parts that meet GB1589 measurement requirement at delivery while not including the license plate.

Note: Rearview mirrors and the deformed portion of tyre wall directly above the touchdown point are not included in the total width.

TECHNICAL DATA

Weights

Item, Units	Parameter		
	1.0T 6AT	1.5L 5MT	1.0T 6MT
Person in cab, person	5		
Unladen vehicle weight (kerb), kg	1255/1264	1215/1231/1239	1259
Gross vehicle weight, kg	1730	1695	1722
Unladen front axle weight, kg	765/769	728/737/741	760
Unladen rear axle weight, kg	490/495	487/494/498	499
Laden front axle weight, kg	872	868	883
Laden rear axle weight, kg	858	827	839

Towing Weights

Item, Units	Parameters
Towing limit unbraked, kg	500
Towing limit braked, kg	500
Towing hitch load, kg	50

Towing Bar Dimensions

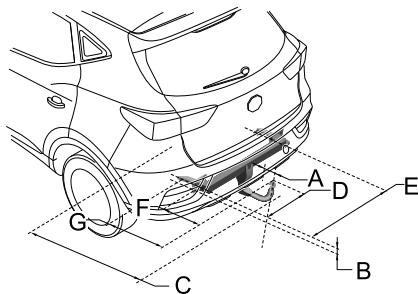

Item	Dimension Description, Units	Parameters
A	Bumper to centre of tow ball, mm	59
B	Attachment point to centre the tow ball, mm	38
C	Wheel centre to centre of tow ball, mm	893
D	Centre of tow ball to side member, mm	469

TECHNICAL DATA

Item	Dimension Description, Units	Parameters
E	Distance between side members, mm	938
F	Centre of tow ball to centre of first attachment point, mm	302
G	Centre of tow ball to centre of second attachment point, mm	438

Major Parameters of Engine

Vehicle	Parameter
	I.0T-AT/MT
Bore × Stroke, mm × mm	74×77.4
Capacity, Litres	0.999
Compression ratio	10.5 : 1
Fuel type, RON	Unleaded 95 RON to EN228 SPEC

TECHNICAL DATA

Vehicle	Parameter
	1.5L-MT
Bore × Stroke, mm × mm	75×84.8
Capacity, Litres	1.498
Compression ratio	11.5:1
Fuel type, RON	Unleaded 95 RON to EN228 SPEC

Recommended Fluids and Capacities

Name	Grade	Capacity		
		1.5L-5MT	1.0T-6MT	1.0T-6AT
Engine oil (after-sales replacement), L	C5 0W-20	4.1	4	
Engine coolant, L	Glycol (OAT)	5.4	5.8	
Automatic transmission oil, L	AW-1	—		6.2
Manual transmission oil, L	MTF94	1.8	—	—
	Castrol BOT503	—	1.7	
Brake fluid, L	DOT 4	0.75		
Washer fluid, L	ZY-VIII	4		
Air conditioning refrigerant, g	R1234yf	520±20		

TECHNICAL DATA

Wheel Alignment (Unladen Condition)

Item		Parameter
Front	Camber angle	$-0^{\circ}36\phi \pm 45\phi$
	Caster angle	$4^{\circ}02\phi \pm 45\phi$
	Toe-in angle (Total)	$0^{\circ}8\phi \pm 15\phi$
	Kingpin Inclination angle	$12^{\circ}05\phi \pm 45\phi$
Rear	Camber angle	$-1^{\circ}15\phi \pm 45\phi$
	Toe-in angle (Total)	$0^{\circ}25\phi \pm 20\phi$

Tyre Pressure (Cold)

Wheels	Unladen
Front Wheels	230kPa/2.3bar/34psi
Rear Wheels	230kPa/2.3bar/34psi

Wheels and Tyres

Wheel size	7J×17
Tyre size	215/55 R17 94V

Appendix

304 Removable Tow Bar

APPENDIX

Removable Tow Bar

Tow Bar Operating Instructions

Safety:

Operation of the detachable tow bar should only be performed by hand, never use hand tools to operate the locking mechanism.

If the trailer is fitted with a security cable or brake cable it must be attached to the dedicated connection hole in the fixed part of the tow bar.

When a stabiliser coupling is installed on the trailer never use grease on the tow ball.

Always remove the detachable tow ball when not in use if it obscures the registration plate.

Preparation:

Remove tow ball cover.

Ensure the tow ball is clean and free from dirt and debris.

Ensure the tow ball is in the 'spring position' (see picture 3.1).

The tow ball is in the spring position if:

- The operating handle is pushed in completely and no colour indication is shown inside the indication area of the operating handle.
- The slider is pulled fully towards the tow ball (shown in picture 3.1).
- It is not possible to lock the system with the supplied locking keys (see picture 5.2).

The tow ball is NOT in the spring position if:

- The operating handle is popped out and shows a red field in the indication area of the operating handle (see picture 3.1)
- The slider is pushed out towards the tow ball (the part is indicated by in picture 3.1).
- It is possible to lock the system with the supplied keys (see picture 5.2).

To place the tow ball in the spring position:

- Unlock the tow ball (see picture 6.1)
- Push the operating handle inwards, rotate in a clockwise direction (whilst pushing inwards) until the handle remains in position (see picture 3.2). If unsure repeat operation.

Note: If a tow ball cannot be tensioned into the spring position it cannot and **MUST NOT** be used.

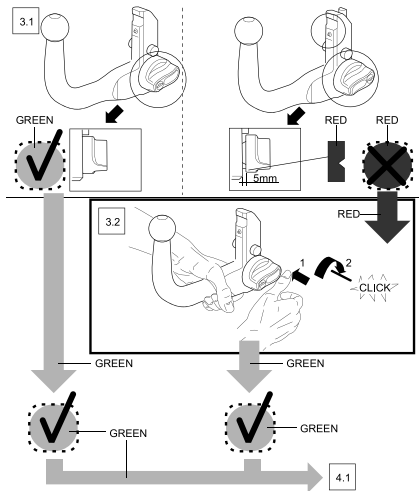

Attachment:

Before attaching the tow ball to the car please remove the cover from the housing (see picture 4.1).

- Insert tow ball (that must be in the spring position) fully into the housing.
- Hold the tow ball in position, keeping your hands away from the operating handle, use a slight force to pull at the tow ball as shown in picture 4.3.
- The unlocking pin will trigger the locking mechanism and the locking process will automatically take place.
- Always check the tow ball is correctly installed, this can be recognised by:
 - The operating handle pops out and an approximate gap of 5 millimeters will be visible between the tow ball and the operating handle (see picture 5.1).
 - A green field will be visible in the indication area of the operating handle (see picture 5.1).
- The tow ball can be locked using the supplied keys (see picture 5.2). This can only be done when the handle has popped out completely, after this the handle can no longer be pushed in and the tow ball cannot be released (remember to remove the keys).

APPENDIX

- Check the tow ball for security – no play should be evident.

The tow ball is now ready for use.

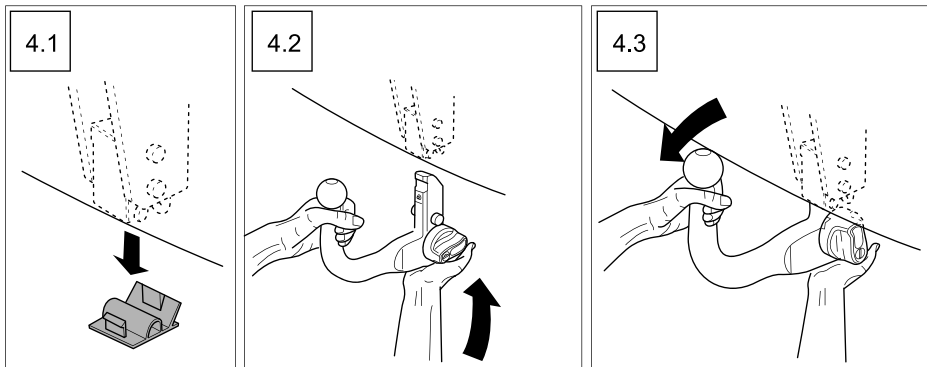

Care Points

- Always check the tow ball for correct mounting every time prior to use.
- Never attempt to attach/detach a tow ball whilst trailer/accessory attached.
- Always keep the tow ball clean and free from debris, do not clean with high pressure washer.
- Never use a tow ball that has signs of damage, excessive wear or modification.
- Never use a tow ball that has been installed by any other method than 'hand pressure'.

Removal

Always disconnect the trailer/accessory and safety cable prior to tow ball removal.

- Unlock the detachable tow ball by turning the locking key clockwise using your thumb and forefinger (see picture 6.1).
- Hold the tow ball with your left hand, push the operating handle fully inwards and turn clockwise until the operating handle remains in position (see picture 6.3).

- The tow ball can now be removed from the housing in a downward motion (see picture 6.4). **WARNING**, this item is heavy, do not allow it to drop.
- Refit the plastic cover into the housing (see picture 6.5).

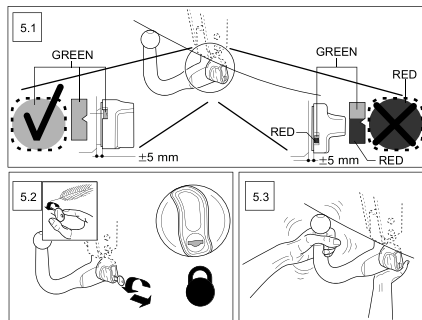

APPENDIX

