

<b>Preface</b> .....	<b>1</b>
<b>Introduction</b> .....	<b>1</b>
The Owner's Handbook .....	1
Status at Time of Printing .....	1
Symbols Used .....	1
In an Emergency.....	2
<b>Vehicle Identification Information</b> .....	<b>3</b>
Vehicle Identification .....	3
Vehicle Identification Label .....	4
<b>I Instruments and Controls</b> .....	<b>5</b>
<b>Instruments and Controls</b> .....	<b>6</b>
<b>Instrument Pack</b> .....	<b>8</b>
<b>Message Centre</b> .....	<b>9</b>
<b>Warning Lights and Indicators</b> .....	<b>21</b>
<b>Lights and Switches</b> .....	<b>34</b>
Master Light Switch .....	34
Headlamp Levelling Adjustment .....	36
Lighting Lever Switch .....	37

# CONTENTS

---

Smart Main Beam System .....	38
Fog Lamp Switch .....	40
Hazard Warning Lamps .....	40
<b>Wipers and Washers .....</b>	<b>41</b>
Front Windscreen Wiper Controls .....	41
Rear Windscreen Wiper Controls .....	43
<b>Steering System .....</b>	<b>45</b>
Adjustment of Steering Column.....	45
Electric Power Steering.....	46
<b>Horn.....</b>	<b>47</b>
<b>Rearview Mirrors .....</b>	<b>48</b>
Exterior Door Mirrors .....	48
Automatic Anti-dazzle Interior Rearview Mirror .....	50
<b>Sunvisor .....</b>	<b>52</b>
<b>Windows.....</b>	<b>53</b>
Power Operated Window Switch .....	53
Window Operation.....	53
<b>Sunroof * .....</b>	<b>56</b>

Instructions .....	56
Sunroof Operation .....	56
<b>Interior Light .....</b>	<b>62</b>
Front Interior Lamp .....	62
Rear Interior Lamp * .....	63
Ambient Lamps * .....	63
<b>Power Socket .....</b>	<b>64</b>
<b>Storage Devices .....</b>	<b>66</b>
Instructions .....	66
Glove Box .....	66
Storage Box – Driver Side .....	67
Centre Console Armrest Box .....	67
Load Space Compartment .....	68
<b>Cup Holder .....</b>	<b>69</b>
Centre Console Cup Holder .....	69
Rear Armrest and Rear Cup Holder .....	69
<b>Roof Luggage Rack * .....</b>	<b>70</b>
Maximum Authorised Load for the Roof.....	70
Periodical Check.....	70

# CONTENTS

---

<b>2 Air Conditioning and Audio Systems .....</b>	<b>71</b>
<b>Ventilation .....</b>	<b>72</b>
A/C Particle/Pollen Filter .....	73
Vents .....	73
<b>Electronic Temperature Control * .....</b>	<b>75</b>
Infotainment Screen Control Interface .....	75
Control Panel .....	78
A/C Display .....	79
<b>Automatic Temperature Control * .....</b>	<b>80</b>
Infotainment Screen Control Interface.....	80
Control Panel .....	83
A/C Status .....	85
<b>Infotainment System.....</b>	<b>86</b>
Important Safety Information .....	86
Cautions for Using Screen .....	87
Additional Notes.....	88
Basic Operations .....	88
Bluetooth Phone.....	94
Entertainment.....	102

Vehicle-Mobile Phone Interconnection *	110
A/C	111
Vehicle Settings	111
Settings	112
<b>3 Seats &amp; Restraints</b>	<b>115</b>
<b>Seats</b>	<b>116</b>
Overview	116
Head Restraint	116
Front Seats	117
Rear Seats	119
Front Seat Heating *	120
<b>Seat Belts</b>	<b>122</b>
Protection Provided by Seat Belts	123
Wearing Seat Belts	124
Children and Seat Belts	129
Seat Belt Pre-tensioners	130
Seat Belt Checks, Maintenance and Replacement	131
<b>Airbag Supplementary Restraint System</b>	<b>133</b>
Overview	133

# CONTENTS

---

Airbag Deployment .....	134
Conditions in Which Airbags Will Not Deploy .....	137
Disabling the Passenger Airbag.....	138
Service and Replacement of Airbags .....	140
Disposal of Airbags.....	141
<b>Child Restraints .....</b>	<b>142</b>
Important Safety Instructions about Using Child Restraints .....	142
Child Restraints Groups.....	145
Approved Child Restraint Positions .....	147
<b>4 Starting &amp; Driving.....</b>	<b>153</b>
<b>Keys .....</b>	<b>154</b>
Overview .....	154
Replacing the Battery .....	155
<b>Child Proof Locks .....</b>	<b>158</b>
<b>Alarm Systems .....</b>	<b>159</b>
Engine Immobiliser .....	159
Vehicle Anti-theft System.....	160
Manual Tailgate * .....	164

Electric Tailgate *	165
Tailgate Emergency Open	168
<b>Starting and Stopping Engine</b>	<b>169</b>
START/STOP Switch	169
Starting the Engine	170
Stopping the Engine	172
<b>Economical and Environmental Driving</b>	<b>173</b>
Running-in	173
Environment Protection	173
Economic Driving and Maintenance	173
Driving in Special Environment	175
<b>Catalytic Converter and Particulate Filter</b>	<b>176</b>
<b>Fuel System</b>	<b>178</b>
Fuel Requirements	178
Fuel Filler	179
Refueling	179
<b>Manual Transmission *</b>	<b>181</b>
<b>Dual Clutch Automatic Transmission *</b>	<b>183</b>
Instructions	183

# CONTENTS

---

Electronic Shift Lever .....	183
Manual Mode * .....	186
Protection Mode .....	187
<b>Driving Mode * .....</b>	<b>189</b>
<b>Brake System .....</b>	<b>192</b>
Foot Brake .....	192
Hill Descent Control (HDC) .....	197
Anti-lock Brake System (ABS) .....	199
Active Rollover Protection (ARP) .....	200
Emergency Braking Hazard Warning Lights Control System (HAZ) .....	201
Electronic Parking Brake (EPB) .....	202
<b>Stability Control System (SCS) and Traction Control System (TCS) .....</b>	<b>204</b>
<b>Tyre Pressure Monitoring System (TPMS) .....</b>	<b>206</b>
<b>STOP-START Intelligent Fuel Saving System .....</b>	<b>207</b>
Automatic Shutdown of Engine .....	208
Automatic Engine Start .....	209
Battery .....	210
Stop-Start Intelligent Fuel Saving System Failure .....	211
Starter Inoperative, Serious Battery Capacity Loss .....	211



<b>Cruise Control System *</b> .....	<b>212</b>
Cruise Control System Activation .....	212
Target Cruise Speed Adjustment .....	213
Pause/Stand By.....	213
Resume .....	214
<b>Adaptive Cruise Control System *</b> .....	<b>215</b>
Adaptive Cruise Control System Activation .....	216
Adaptive Cruise Target Speed Adjustment .....	219
Adaptive Cruise Target Following Distance Adjustment .....	220
Adaptive Cruise Pause.....	220
Automatic Deactivation of Adaptive Cruise .....	220
Adaptive Cruise Override .....	221
Adaptive Cruise Resume .....	221
Clear the Speed Memory .....	221
Special Driving Environments .....	222
<b>Parking Aid System *</b> .....	<b>225</b>
Ultrasonic Sensor Parking Aid * .....	225
Parking Camera * .....	226
<b>Rear Driver Assistance System.....</b>	<b>227</b>

# CONTENTS

---

System Overview .....	227
Switching the System Functions On/Off .....	228
System Functions .....	229
<b>Driving Assist System .....</b>	<b>235</b>
Description of Front View Camera .....	235
Description of Front Detection Radar .....	236
Speed Assist System (SAS) .....	238
Lane Departure Warning System (LDW) .....	243
Lane Departure Prevention System (LDP) .....	247
Lane Keeping Assist System (LKA) .....	251
MG Pilot System * .....	255
Forward Collision Warning System (FCW) .....	259
Automatic Emergency Braking System (AEB) and Automatic Emergency Braking System for Pedestrians (AEBP) .....	261
<b>Load Carrying .....</b>	<b>266</b>
Load Space .....	266
Internal Loading .....	267
General Towing Safety .....	267
<b>5 Emergency Information .....</b>	<b>269</b>

<b>Hazard Warning Devices</b> .....	<b>270</b>
Hazard Warning Lamps.....	270
Warning Triangle.....	270
<b>eCall - SOS Emergency Assistance</b> .....	<b>272</b>
<b>Emergency Starting</b> .....	<b>274</b>
Using Booster Cables .....	274
Starting the Vehicle .....	274
<b>Vehicle Recovery</b> .....	<b>276</b>
Towing for Recovery.....	276
Transporter .....	279
<b>Tyre Repair</b> .....	<b>280</b>
Tool Identification (including tyre repair tool).....	280
Tyre Repair .....	280
Changing a Wheel * .....	283
<b>Fuse Replacement</b> .....	<b>287</b>
Fuse .....	287
Fuse Box .....	287
<b>Bulb Replacement</b> .....	<b>294</b>

# CONTENTS

---

Bulb Specification.....	294
Bulb Replacement.....	294
<b>6 Maintenance .....</b>	<b>301</b>
<b>Maintenance .....</b>	<b>302</b>
Routine Servicing .....	302
<b>Bonnet .....</b>	<b>306</b>
Opening the Bonnet .....	306
Closing the Bonnet .....	306
Bonnet Open Alarm .....	306
<b>Engine Compartment.....</b>	<b>308</b>
<b>Engine .....</b>	<b>309</b>
1.5L Turbocharged Engine Oil .....	309
Engine Oil Level Check and Top Up .....	309
Engine Oil Specification .....	310
<b>Cooling System .....</b>	<b>311</b>
Coolant Check and Top Up .....	311
Coolant Specification .....	311
<b>Brake .....</b>	<b>313</b>

Brake Pads .....	313
Brake Fluid Check and Top Up .....	313
Brake Fluid Specification .....	314
<b>Battery</b> .....	<b>315</b>
Battery Maintenance .....	315
Battery Replacement.....	315
<b>Washer</b> .....	<b>317</b>
Washer Fluid Check and Top Up .....	317
Washer Nozzles .....	318
<b>Wipers</b> .....	<b>319</b>
Wiper Blades .....	319
Replacing Front Windscreen Wiper Blades .....	320
Replacing Rear Window Wiper Blades .....	321
<b>Tyres</b> .....	<b>322</b>
Overview .....	322
Tyre Check .....	324
Tyre Wear Indicators .....	324
Replacement of Tyres .....	325
Wheel Fitment Rotation .....	325

# CONTENTS

---

Tyre/Snow Chains .....	326
<b>Cleaning and Vehicle Care .....</b>	<b>328</b>
External Care .....	328
Cleaning the Interior.....	331
<b>7 Technical Data.....</b>	<b>333</b>
<b>Technical Data Dimensions .....</b>	<b>334</b>
<b>Weights.....</b>	<b>336</b>
Towing Weights.....	337
Towing Bar Dimensions.....	338
<b>Major Parameters of Engine .....</b>	<b>340</b>
<b>Recommended Fluids and Capacities .....</b>	<b>341</b>
<b>Four-Wheel Alignment Parameter Table (Unladen).....</b>	<b>342</b>
<b>Wheels and Tyres .....</b>	<b>342</b>
<b>Tyre Pressure (Cold) .....</b>	<b>342</b>
<b>8 Appendix.....</b>	<b>343</b>
<b>Removable Tow Bar .....</b>	<b>344</b>
Tow Bar Operating Instructions.....	344

## Introduction

### The Owner's Handbook

This handbook describes all of the vehicles and standard equipment specification within the model range. Some of the information therefore, may not apply to your particular car.

Always remember that if you have any queries concerning the operation or specification of your car, your MG Authorised Repairer will be glad to advise you.

### Status at Time of Printing

MG operates a policy of constant product improvement and therefore reserves the right to change specifications without notice at any time. Whilst every effort is made to ensure complete accuracy of the information in this publication, no liabilities for inaccuracies or the consequences thereof, including loss or damage to property, or injury to persons, can be accepted by the manufacturer or MG Authorised Repairer who supplied the publication, except in respect of personal injury caused by the negligence of the manufacturer or MG Authorised Repairer.

## Symbols Used

The following symbols used within the handbook call your attention to specific types of information.

### Warning



*This warning symbol identifies procedures that must be followed precisely, or information that must be considered with great care, in order to reduce the risk of personal injury or serious damage to the car.*

### Important

IMPORTANT
The statements stated here must be followed strictly, otherwise your car could be damaged.

### Note

**Note:** *This describes helpful information.*

# PREFACE

---



This symbol indicates parts described must be disposed of by authorised persons or bodies to protect the environment.

## Asterisk

An asterisk (\*) appearing within the text, identifies features or items of equipment that are either optional, or are only fitted to some vehicles in the model range.

## Illustration Information



Identifies components being explained.



Identifies movement of components being explained.

## In an Emergency

### IMPORTANT

#### Remember the breakdown safety code

If a breakdown occurs while travelling:

- Wherever possible, consistent with road safety and traffic conditions, the car should be moved off the main thoroughfare, preferably into a lay-by. If a breakdown occurs on a motorway, pull well over to the inside of the hard shoulder.
- Switch on hazard lights.
- If available, position a warning triangle or a flashing amber light 150 to 500 ft behind your vehicle to warn approaching traffic. Note it is a legal requirement of some countries that a warning triangle is carried in the vehicle, if in doubt consult the local highways agency for further information.
- Consider evacuating passengers through nearside doors onto the verge as a precaution in case your vehicle is accidentally struck by other traffic.



## Vehicle Identification Information

### Vehicle Identification

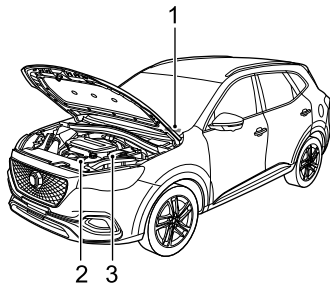

- 1 Vehicle Identification Number (VIN)
- 2 Engine Number
- 3 Transmission Number

Always quote the Vehicle Identification Number (VIN) when communicating with your MG Authorised Repairer.

If the engine or transmission is involved, it may be required to provide the identification numbers of these assemblies.

### Vehicle Identification Location

#### VIN Location

- On the floor under the front driver seat;
- Stamped on a plate visible through the bottom left hand corner of the windscreen;
- On the identification plate;
- On the inner side of the tailgate visible by opening the tailgate.

**Note:** The DLC of the vehicle is located on the upper left of the brake pedal. The VIN information can be extracted from the vehicle using the approved diagnostic equipment.

#### Engine Number Location

Stamped on the front right of the cylinder block (View from the front of the engine).

#### Transmission Number Location

# PREFACE

---

On the surface of the transmission housing in the engine compartment. The transmission numbers of certain models are only visible by raising the vehicle, please contact a local Authorised Repairer.

## Vehicle Identification Label

The vehicle identification label contains the following information:

- Model /Type;
- Engine Type;
- Vehicle Identification Number (VIN);
- Date;
- Gross Vehicle Weight;
- Gross Train Weight \*;
- Max Front Axle Weight \*;
- Max Rear Axle Weight \*;
- Country;
- Manufacturer.

## Location of Vehicle Identification Label

The identification label is located at the lower side of right pillar B

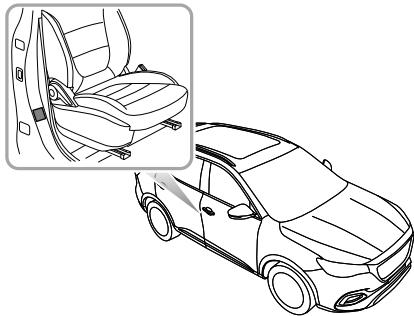

## ***Instruments and Controls***

---

- |    |                                      |    |                            |
|----|--------------------------------------|----|----------------------------|
| 6  | <i>Instruments and Controls</i>      | 64 | <i>Power Socket</i>        |
| 8  | <i>Instrument Pack</i>               | 66 | <i>Storage Devices</i>     |
| 9  | <i>Message Centre</i>                | 69 | <i>Cup Holder</i>          |
| 21 | <i>Warning Lights and Indicators</i> | 70 | <i>Roof Luggage Rack *</i> |
| 34 | <i>Lights and Switches</i>           |    |                            |
| 41 | <i>Wipers and Washers</i>            |    |                            |
| 45 | <i>Steering System</i>               |    |                            |
| 47 | <i>Horn</i>                          |    |                            |
| 48 | <i>Rearview Mirrors</i>              |    |                            |
| 52 | <i>Sunvisor</i>                      |    |                            |
| 53 | <i>Windows</i>                       |    |                            |
| 56 | <i>Sunroof *</i>                     |    |                            |
| 62 | <i>Interior Light</i>                |    |                            |

# INSTRUMENTS AND CONTROLS

---

## Instruments and Controls

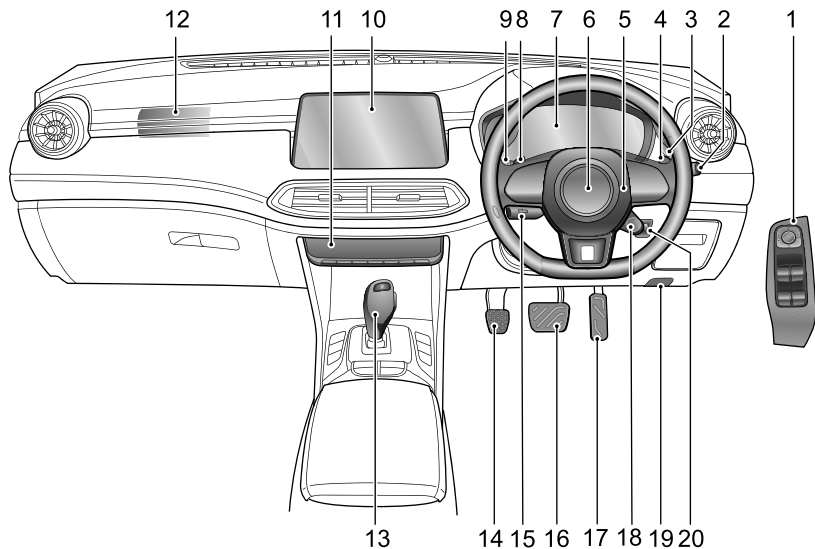

# INSTRUMENTS AND CONTROLS

---

- |   |   |
|---|---|
| 1 Exterior Rearview Mirrors and Power Window Switch | 17 Accelerator Pedal                    |
| 2 Wiper/Washer Control                              | 18 Super Sport Button *                 |
| 3 START/STOP Switch                                 | 19 Bonnet Release Handle                |
| 4 Gear Paddle + *                                   | 20 Headlamp Levelling Adjustment Switch |
| 5 Horn Button                                       |   |
| 6 Driver Airbag                                     |   |
| 7 Instrument Pack                                   |   |
| 8 Gear Paddle - *                                   |   |
| 9 Indicator and Main Beam Stalk Switch              |   |
| 10 Onboard Entertainment System                     |   |
| 11 Entertainment/Air Conditioning Controls          |   |
| 12 Front Passenger Airbag                           |   |
| 13 Gear Shift Lever                                 |   |
| 14 Clutch Pedal *                                   |   |
| 15 Cruise Stalk Switch                              |   |
| 16 Brake Pedal                                      |   |

# INSTRUMENTS AND CONTROLS

## Instrument Pack

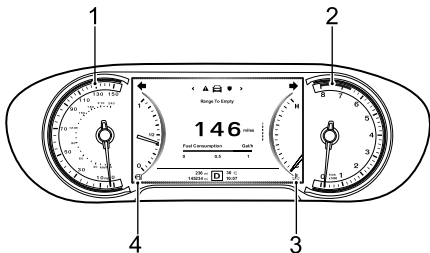

### Speedometer (1)

Indicates the vehicle speed in mph and km/h.

### Tachometer (2)

Indicates the engine speed,  $\times 1000$  rpm.

#### IMPORTANT

To protect the engine from damage, never allow the pointer to remain in the red sector of the gauge for prolonged periods.

### Engine Coolant Temperature Gauge (3)

Indicates the engine coolant temperature.

### Fuel Gauge (4)

Indicates the quantity of fuel in the tank.

The low fuel warning lamp will illuminate yellow or flash when the fuel remaining in the fuel tank is low.

#### IMPORTANT

If the low fuel warning lamp illuminates, please refuel as early as possible.



The arrow to the left of low fuel warning lamp indicates that the fuel filler is located on the left side of the vehicle.

## Message Centre

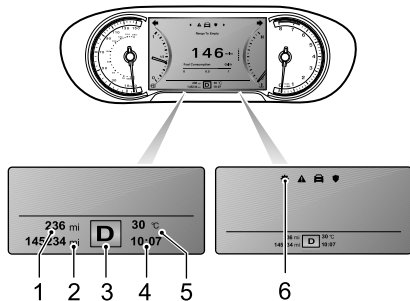

The message centre provides the followings:

- 1 Accumulative Trip Meter
- 2 Odometer
- 3 Gear Display / Gear Shift Indication / Power System Mode Display \*
- 4 Digital Clock

5 Exterior Ambient Temperature

6 Vehicle Information Display

## Accumulative Trip Meter

Displays the trip meter since reset.

## Odometer

Displays the total distance the car has travelled.

## Gear Display / Gear Shift Indication / Power System Mode Display \*

For automatic transmission, the current gear position will be displayed (P, R, N, D, S, 1, 2, 3, 4, 5, 6, 7). When a gear change is advised, an up or down arrow will be displayed above or under the gear position.

For manual transmission, it displays N, R and the advised gear (1-6), an Up/Down arrow indicates to the driver to either upshift or downshift to the displayed gear when driving conditions permit.

# INSTRUMENTS AND CONTROLS

---

If 'EP' is displayed, it indicates a fault with the automatic transmission. Please contact a local MG Authorised Repairer immediately.

For more information, please refer to “Manual Transmission” and “Dual Clutch Automatic Transmission” in “Starting & Driving” section.

Power system mode (N, S, E) is also displayed. For more information about power system mode, please refer to “Driving Mode” in “Starting & Driving” section.

## Digital Clock

Displays the current time in digital form.

## Exterior Ambient Temperature

Displays the current exterior ambient temperature in digital form.

## Vehicle Information Display

With the START/STOP switch in ON/RUNNING position, the vehicle information display can be selected as follows:

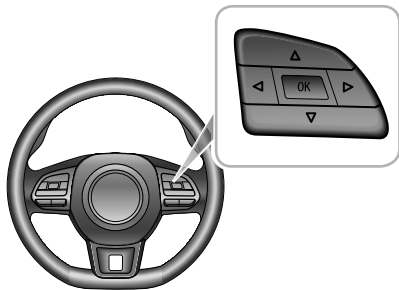

- Press the LEFT/RIGHT/UP/DOWN button on the right hand multifunction steering wheel to shift the display items.
- Press the UP/DOWN button on the right hand multifunction steering wheel to make adjustment.
- Press OK button on the right hand multifunction steering wheel to confirm or long press OK button to reset.



The vehicle information display contains the following information:

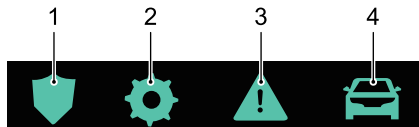

- 1 Active Safety
- 2 Setting
- 3 Warning Information
- 4 Trip Computer

## **Active Safety**

Displays the active safety information of the vehicle.

For more information, please refer to “Driving Assist System” in “Starting & Driving” section.

## **Setting**

## **Luminance Level**

Displays the current luminance level of the instruments and switches, this can be adjusted. There are 3 levels in total.

## **OverSpeed Threshold**

You can set the value of overspeed threshold.

## **ECO**

This refers to the ECO driving mode, it can be set to On or Off.

## **Next Service**

Displays the current vehicle maintenance information. It can be reset by long pressing the OK button on the right hand multifunction steering wheel.

## **Warning Information**

Displays the warning information or important notes that are currently relevant to the vehicle.

## **Trip Computer**

# INSTRUMENTS AND CONTROLS

---

The following information is available and can be selected for display.

- **Range to Empty:** displays the range that the vehicle can travel before the fuel tank is empty, the value of the range will change after refueling.
- **Fuel Consumption:** displays the current fuel consumption when the engine is working.
- **Digital Speed:** displays the current vehicle speed.
- **Current Journey:** displays the range, duration, average speed and average fuel consumption since startup. These values will be reset after a period of power off. It can also be reset by long pressing the OK button on the right hand multifunction steering wheel.
- **Accumulated Total:** displays the range, duration, average speed and average fuel consumption since the last reset. It can be reset by long pressing the OK button on the right hand multifunction steering wheel.
- **12V Battery Voltage:** displays the 12V Battery Voltage.
- **Pressure Monitoring:** displays the current tyre pressure data for each wheel.

## Warning Message

Warning messages and prompts are displayed in the information message centre in the instrument pack. Any communications are displayed in 'pop up' messages, these can be divided into the following categories:

- Operating Instruction
- System State Instruction
- System Malfunction Alert

Please follow the instructions displayed in the 'pop up' message or in the case of a warning message, please refer to the relevant section of the owners manual to follow the correct instructions.

The following are a selection of warning messages that may appear in the information message centre.

## INSTRUMENTS AND CONTROLS

1

Warning Message	Procedure
Cruise Control Fault Consult Handbook	Indicates that the cruise control system is failed. Please contact a local MG Authorised Repairer as soon as possible.
Engine Coolant Temperature High	High engine coolant temperature could result in severe damage. Stop the car as soon as safety permits, shut down the engine and contact a local MG Authorised Repairer immediately.
Engine Coolant Temperature Sensor Fault Consult Handbook	Indicates that the engine coolant temperature sensor has failed. Please contact a local MG Authorised Repairer immediately.

Warning Message	Procedure
Check Engine Consult Handbook	Indicates that a failure has occurred that may severely damage the engine has occurred, stop the car as soon as safety permits, shut down the engine and contact a local MG Authorised Repairer immediately.
Engine Fault Consult Handbook	Indicates that a failure has occurred that will effect engine performance and missions.Please contact a local MG Authorised Repairer as soon as possible.
12V Battery Charging System Fault	Indicates that 12V low-voltage battery charging system has failed. Please contact a local MG Authorised Repairer immediately.

## INSTRUMENTS AND CONTROLS

---

Warning Message	Procedure
Low Oil Pressure Consult Handbook	Indicates that the oil pressure is too low, which may result in severe engine damage. Stop the vehicle as soon as safety permits and shut down the engine, check the oil level and contact a local MG Authorised Repairer immediately.
Stop Start System Fault Consult Handbook	Indicates that the Start-Stop intelligent fuel saving system has failed. Please contact a local MG Authorised Repairer as soon as possible.
Ignition System Fault Consult Handbook	Indicates that the power mode has failed. Please contact a local MG Authorised Repairer immediately.

Warning Message	Procedure
Start Stop Button Fault Consult Handbook	Indicates that the START/STOP switch has failed. Please contact a local MG Authorised Repairer immediately.
Passive Entry Fault Consult Handbook	Indicates that keyless entry function has failed. Please contact a local MG Authorised Repairer as soon as possible.
ABS Fault Consult Handbook	Indicates that the ABS system has failed, and anti-lock brake function will be disabled. Please contact a local MG Authorised Repairer immediately.

## INSTRUMENTS AND CONTROLS

1

Warning Message	Procedure
Brake Fault Consult Handbook	Indicates that a failure within the braking system, such as brake fluid low/loss or Electronic Brake-force distribution failure has occurred, stop the vehicle as soon as safety permits and shut down the engine, check the brake fluid level and contact a local MG Authorised Repairer immediately.
Stability Control Fault Consult Handbook	Indicates that SCS system has failed. Please contact a local MG Authorised Repairer immediately.
Traction Control Fault Consult Handbook	Indicates that TCS system has failed. Please contact a local MG Authorised Repairer immediately.
EPB System Fault Consult Handbook	Indicates that EPB system has failed. Please contact a local MG Authorised Repairer as soon as possible.

Warning Message	Procedure
Park Brake Force Not Enough	Indicates that the EPB system has failed during parking. Please contact a local MG Authorised Repairer as soon as possible.
Autohold Fault Consult Handbook	Indicates that auto hold function has failed. Please contact a local MG Authorised Repairer as soon as possible.
Hill Descent Control Fault Consult Handbook	Indicates that HDC system has failed. Please contact a local MG Authorised Repairer as soon as possible.

## INSTRUMENTS AND CONTROLS

---

Warning Message	Procedure
EPS Performance Reduced	Indicates that the electric power steering system has a general failure and that the steering performance has been reduced. As soon as conditions permit, safely stop the vehicle and switch the vehicle power system to the OFF position. After a short while, switch the vehicle power system to the ON/RUNNING position, drive the vehicle a short distance and monitor the operation of the steering. If the message is still displayed or the steering assistance reduced, please contact a local MG Authorised Repairer immediately.

Warning Message	Procedure
EPS Assistance Failure Consult Handbook	Indicates that the electric power steering system has failed. Please contact a local MG Authorised Repairer immediately.
Steering Angle Fault Consult Handbook	Indicates that the steering angle sensor has failed. Please contact a local MG Authorised Repairer as soon as possible.
Steering Angle Uncalibrated Consult Handbook	Indicates that the steering angle sensor is not calibrated. Please contact a local MG Authorised Repairer as soon as possible.
ESCL Fault Consult Handbook	Indicates that the ESCL system has failed. Stop the car as soon as safety permits, shut down the engine and contact a local MG Authorised Repairer immediately.

## INSTRUMENTS AND CONTROLS

1

Warning Message	Procedure
Vacuum System Fault	Indicates that the vacuum system has failed. Please contact a local MG Authorised Repairer immediately.
Fuel Sensor Fault Consult Handbook	Indicates that the fuel sensor has failed. Please contact a local MG Authorised Repairer as soon as possible.
Airbag Fault Consult Handbook	Indicates that the SRS system has failed, stop the car as soon as safety permits, shut down the engine and contact a local MG Authorised Repairer immediately.
Airbag Lamp Fail	Indicates that the airbag lamp has failed. Please contact a local MG Authorised Repairer as soon as possible.

Warning Message	Procedure
Power Tailgate System Fault Consult Handbook	Indicates that the electric tailgate system has failed. Please contact a local MG Authorised Repairer as soon as possible.
TPMS Fault Consult Handbook	Indicates that the tyre pressure monitoring system (TPMS) has failed. Please contact a local MG Authorised Repairer as soon as possible.
Front Left/Front Right/Rear Left/Rear Right Tyre Sensor Battery Low	Indicating TPMS sensor low battery. Please contact a local MG Authorised Repairer as soon as possible.
Park Assist System Fault Consult Handbook	Indicates that PDC system has failed. Please contact a local MG Authorised Repairer as soon as possible.

## INSTRUMENTS AND CONTROLS

Warning Message	Procedure
Rear Drive Assist System Fault Consult Handbook	Indicates that the rear drive assist system (RDA) has detected a fault. Please contact a local MG Authorised Repairer as soon as possible.
Front Camera System Fault Consult Handbook	It indicates that the front camera has detected a fault. Please contact a local MG Authorised Repairer as soon as possible.
Front Camera Calibration Failed	Indicates that the front view camera module (FVCM) calibration has failed. Please contact a local MG Authorised Repairer as soon as possible.
RADAR Calibration Failed	Indicates that the radar module calibration has failed. Please contact a local MG Authorised Repairer as soon as possible.

Warning Message	Procedure
Lane Departure Warning System Fault Consult Handbook	Indicates that the lane departure warning system (LDW) has detected a fault. Please contact a local MG Authorised Repairer as soon as possible.
Lane Keep Assist System Fault Consult Handbook	Indicates that the lane keep assist system (LKA) has detected a fault. Please consult an MG Authorised Repairer as soon as possible.
ACC System Fault Consult Handbook	Indicates that the adaptive cruise control system (ACC) has detected a fault. Please contact a local MG Authorised Repairer as soon as possible.
Auto Emergency Braking System Fault Consult Handbook	Indicates that the auto emergency braking system (AEB) has detected a fault. Please contact a local MG Authorised Repairer as soon as possible.



## INSTRUMENTS AND CONTROLS

1

Warning Message	Procedure
Pedestrian Auto Emergency Braking Fault Consult Handbook	Indicates that the auto emergency braking system for pedestrians (AEBP) has detected a fault. Please contact a local MG Authorised Repairer as soon as possible.
Forward Collision System Fault Consult Handbook	Indicates that the forward collision warning system (FCW) has detected a fault. Please contact a local MG Authorised Repairer as soon as possible.
MSA Fault	Indicates that the Manual Speed Assist (MSA) function has failed. Please contact a local MG Authorised Repairer as soon as possible.

Warning Message	Procedure
ISA Fault	Indicates that the Intelligent Speed Assist (ISA) function has failed. Please contact a local MG Authorised Repairer as soon as possible.
MG Pilot System Fault Consult Handbook	Indicates that the MG Pilot system has detected a fault. Please contact a local MG Authorised Repairer as soon as possible.
eCall System Fault Consult Handbook	Indicating to the driver with a yellow SOS warning lamp that the eCall system is faulty and not operating within its parameters. The SOS button LED status indicator flashes twice per second. Please contact a local MG Authorised Repairer as soon as possible.

## INSTRUMENTS AND CONTROLS

---

Warning Message	Procedure
eCall System Failure Consult Handbook	Indicating to the driver with a red SOS warning lamp that the eCall system has failed and not capable of supporting in the event of an accident. The SOS button LED status indicator is not illuminated. Please contact a local MG Authorised Repairer immediately.

Warning Message	Procedure
eCall in Progress	Indicating to the driver with a green SOS warning lamp that an emergency services call is currently in progress. The SOS button LED status indicator flashes once per second.
Auto eCall Disabled Consult Handbook	Indicating to the driver with a red SOS warning lamp that automatic eCall service is disabled. Please contact a local MG Authorised Repairer to reactivate the automatic eCall function.

## Warning Lights and Indicators

Some warning lamps illuminate or flash accompanied by a warning tone. Certain warning lamps will be accompanied by a momentary warning symbol and text message displayed in the information centre in the instrument pack.

### Main Beam Indicator - Blue



With the main beam headlamps turned on, this lamp illuminates.

### Auto Main Beam Indicator - Green



The indicator illuminates when the auto main beam function is enabled.

### Dipped Beam Off - Yellow



The indicator illuminates to indicate to the driver that the dipped beam lamps are switched off and that it is necessary to turn them on. The indicator flashes

first and then remains on after a period of time or until the driver switches the dipped beam lamps on.

### Dipped Beam Indicator - Green \*



With the dipped beam headlamps turned on, this lamp illuminates.

### Side Lamp Indicator - Green



The indicator illuminates when the side lamps are on.

### Rear Fog Lamp Indicator - Yellow



The indicator illuminates when the rear fog lamps are on.

# INSTRUMENTS AND CONTROLS

---

## Front Fog Lamp Indicator - Green



The indicator illuminates when the front fog lamps are on.

## Direction Indicator - Green



The left and right direction indicator lamps are represented by directional arrows that are located at the top of the instrument pack. When the turning signal lamp flashes, the direction indicator lamp on the corresponding side also flashes. If the hazard warning lamps are operated, both direction indicator lamps will flash together. If either direction indicator lamp in the instrument pack flashes very rapidly, it indicates that the turning signal light on the corresponding side has failed.

**Note:** *Failure of a side repeater lamp will have no effect on the flash frequency of direction indicator lamp.*

## ECO Driving Mode Indicator—Green \*



With the ECO driving mode set to ON, if the car is driving in ECO mode, this lamp illuminates. If the ECO driving mode display is set to OFF or the car is not driving in ECO mode, this lamp does not illuminate.

## Driving Mode Indicator \*



Indicates the driving mode of the current vehicle: NORMAL, SPORT, ECO, CUSTOM and SUPER SPORT.

Please refer to "Driving Mode " in "Starting and Driving" chapter for more information.

## Cruise Control Indicator - Green/Yellow \*



If the cruise is switched on, the cruise control system will enter into standby state, and the indicator illuminates in yellow.

When the cruise control system operates, this indicator illuminates green, indicating the cruise control system is activated.

If a failure in the cruise control system is detected, the indicator will flash in yellow. Please contact a local MG Authorised Repairer as soon as possible.

## Engine Coolant Temperature Warning - Red



When the engine coolant temperature warning lamp illuminates red, it indicates that the coolant temperature is high. If the engine coolant temperature continues to rise, the engine coolant temperature warning lamp will flash.

High engine coolant temperature could result in severe damage. Stop the vehicle and switch off the engine as soon as safety permits and contact a local MG Authorised Repairer immediately.

## Engine Malfunction Warning - Yellow



This lamp will illuminate if an engine fault occurs that will effect engine performance during driving. Stop the vehicle and switch off the engine as soon as safety permits and contact a local MG Authorised Repairer immediately.

## Engine Emissions Malfunction Warning - Yellow



If the fuel filler cap is left off, not fastened correctly, a fuel system fault occurs or an engine fault occurs that will effect engine performance and emission after starting the vehicle, this lamp will illuminate. Please tighten the fuel filler cap. If the lamp keeps on, please contact a local MG Authorised Repairer as soon as possible.

## Alternator Malfunction Warning - Red



If this lamp illuminates after starting the vehicle, it indicates that the 12v battery charging system has a

# INSTRUMENTS AND CONTROLS

---

failure. Please contact a local MG Authorised Repairer immediately.

In cases of low battery power, the prompt messages will appear in the information centre. In this case, the system will limit or turn off some electrical devices, please start the vehicle to charge the battery.

## Low Oil Pressure Warning - Red



If this lamp illuminates after starting the vehicle, it indicates that the oil pressure is too low, which may result in severe engine damage. Stop the vehicle as soon as safety permits and SWITCH OFF THE ENGINE IMMEDIATELY. Check the oil level (Refer to “Engine Oil Level Check and TOP UP” in “Maintenance” chapter). Contact a local MG Authorised Repairer immediately.

## Start-Stop Intelligent Fuel Saving System Status Indicator - Green



If the Start-Stop intelligent fuel saving system is activated, this lamp illuminates to inform the driver that the engine is controlled by the system.

## Start-Stop Intelligent Fuel Saving System Malfunction Warning Lamp - Yellow



If the Start-Stop intelligent fuel saving system has a failure, this lamp illuminates. Please contact a local MG Authorised Repairer as soon as possible.

## Electric Power Steering (EPS)/ Electric Steering Column Lock (ESCL) Warning - Red/Yellow



The warning lamp is used to indicate electric power assisted steering failure or electronic steering column lock failure.

When this lamp illuminates yellow, it indicates the electric power assisted steering system has a general failure and the performance is reduced. Please stop the car as soon as safety permits. If the lamp still illuminates after restarting the vehicle and driving for a short while, please contact a local MG Authorised Repairer immediately.

When this lamp illuminates red, it indicates the electric power assisted steering system has a general failure relevant to steering angle sensing. Please contact a local MG Authorised Repairer as soon as possible.

When this lamp illuminates red and flashes, it indicates the electric power assisted steering system has a severe failure. Please contact a local MG Authorised Repairer immediately.

When the lamp illuminates yellow and continually flashes accompanied with an audible warning, it indicates the electric steering column lock has a failure. Please contact a local MG Authorised Repairer as soon as possible. If this lamp extinguishes after flashing for a while, it indicates that

the steering wheel is locked, please attempt to rotate the steering wheel to remove any adverse loads.

### **Tyre Pressure Monitoring System (TPMS)**

#### **Warning - Yellow**



The warning lamp is used to indicate that a tyre pressure is low, please check the tyre pressures.

If this lamp flashes first and then remains illuminated after a period of time, it indicates the system has a failure. Please contact a local MG Authorised Repairer as soon as possible.

#### **ABS Malfunction Warning Lamp - Yellow**



This lamp illuminates to indicate an ABS fault. Please contact a local MG Authorised Repairer as soon as possible.

If an ABS failure occurs while driving, ABS will function abnormally, but normal braking will still be available.

## INSTRUMENTS AND CONTROLS

---

Please contact a local MG Authorised Repairer as soon as possible.

### **Hill Descent Control (HDC) ON/Malfunction Warning - Green/Yellow**



With the HDC switch pressed, if the lamp illuminates green, it indicates the HDC system has entered the Standby mode. When the lamp flashes green, it indicates that the system is currently under the control of HDC. Press the HDC switch again, the lamp extinguishes, it indicates the HDC function is deactivated.

If a HDC related system suffers a failure, this lamp illuminates yellow. Please contact a local MG Authorised Repairer as soon as possible.

If this lamp illuminates yellow and flashes, it indicates that the brake system is too hot and the HDC system is disabled.

### **Stability Control/Traction Control System Warning Lamp - Yellow**



This lamp illuminates to indicate that there is a failure in the system. Please contact a local MG Authorised Repairer immediately.

If this lamp flashes during driving, it indicates the system is operating to assist the driver.

### **Stability Control/Traction Control System OFF Warning Lamp - Yellow**



If the stability control/traction control system is switched off manually, this warning lamp will illuminate.

### **Brake System Malfunction Warning Lamp - Red**



This lamp illuminates to indicate a failure with the braking system such as brake fluid loss or electronic brake force distribution failure.



Please stop the vehicle as soon as safety permits, shut down the engine, check the brake fluid level (refer to "Brake Fluid Check and Top Up" in "Maintenance" section) and contact a local MG Authorised Repairer for service immediately.

## Seat Belt Unfastened Warning - Red



The lamp illuminates or flashes to indicate that the seat belt for the driver or the passenger remains unfastened.

## Airbag Warning Lamp - Red



This lamp illuminates to indicate a SRS failure or seat belt failure has been detected. In this case, please stop the vehicle as soon as safety permits, shut down the engine immediately, and contact a local MG Authorised Repairer for service at the earliest opportunity. Failure to follow the above may result in the SRS or seatbelt not working correctly in the event of a crash or accident.

## Anti-theft System Warning - Red



If no valid key is detected, this lamp illuminates red, please use the correct key or put the smart key at the bottom of the centre console cup holder. For specific position, please refer to "Alternative Starting Procedure" of "Starting the Engine" in "Starting & Driving" chapter.

If the remote key battery power is low, this lamp flashes. Please replace it as soon as possible.

## Electronic Parking Brake (EPB) / Auto Hold Status Indicator - Red/Green



If this lamp illuminates red, it indicates the EPB system is enabled. If this lamp illuminates red and flashes, it indicates that the EPB system has a failure. Please contact a local MG Authorised Repairer as soon as possible.

When the auto hold system is operating to assist the driver, this lamp illuminates green.

# INSTRUMENTS AND CONTROLS

---

## Electronic Parking Brake (EPB) System Malfunction Warning Lamp - Yellow



If electronic parking brake system failure is detected or the system is under diagnosis, the lamp will illuminate. Please contact a local MG Authorised Repairer as soon as possible.

## Low Fuel Warning Lamp - Yellow



The warning lamp illuminates yellow when the fuel remaining in the fuel tank is low. If possible, please refuel before the low fuel warning lamp illuminates.

When the fuel level continues to fall, this lamp flashes. When fuel is added to the tank and the fuel level rises above the alert limit, this lamp extinguishes. If it does not extinguish, please contact a local MG Authorised Repairer for service as soon as possible.

**Note:** *When driving on steep or rough roads while the fuel level is low, the warning lamp may illuminate.*

## System Fault Messages Indicator - Yellow



This indicator is used to alert the driver to the fact that there is a warning stored in the vehicle IPK system. Please refer to "Information Centre" in this section for these failures.

## Lane Departure Warning System Indicator - Green/Yellow



This lamp will illuminate yellow when the Lane Departure Warning function is enabled, the lamp will extinguish when the function is disabled.

This lamp will illuminate green when the Lane Departure Warning function is activated.

If the Lane Departure Warning System is not able to function normally the lamp will flash yellow and then remain on after a period of time. Please contact a local MG Authorised Repairer for service as soon as possible.

For more information, please refer to “Lane Departure Warning System (LDW)” in “Starting & Driving” section.

## **Lane Departure Prevention System Indicator - Green/Yellow**



This lamp will illuminate yellow when the Lane Departure Prevention function is enabled, the lamp will extinguish when the function is disabled.

This lamp illuminates green when the Lane Departure Prevention function is activated.

If the Lane Departure Prevention System is not able to function normally the lamp will flash yellow and then remain on after a period of time. Please contact a local MG Authorised Repairer.

For more information, please refer to “Lane Departure Prevention System (LDP)” in “Starting & Driving” section.

## **Lane Keeping Assist System Indicator - Green/Yellow**



This lamp will illuminate yellow when the Lane Keeping Assist function is enabled, the lamp will extinguish when the function is disabled.

This lamp illuminates green when the Lane Keeping Assist function is activated.

If the Lane Keeping Assist System is not able to function normally the lamp will flash yellow and then remain on after a period of time. Please contact a local MG Authorised Repairer.

For more information, please refer to “Lane Keeping Assist System (LKA)” in “Starting & Driving” section.

## **MG Pilot System Indicator - Green/Yellow \***



This lamp will illuminate yellow when the MG Pilot function is enabled, the lamp will extinguish when the function is disabled.

# INSTRUMENTS AND CONTROLS

---

This lamp illuminates green when the MG Pilot function is activated.

If the MG Pilot System is not able to function normally the lamp will flash yellow and then remain on after a period of time. Please contact a local MG Authorised Repairer as soon as possible.

For more information, please refer to “MG Pilot System” in “Starting & Driving” section.

## **Forward Collision Assist System (FCW/AEB/AEBP) Indicator - Yellow**



This lamp will illuminate yellow when one of the forward collision assist system (FCW/AEB/AEBP) functions is disabled.

When all of the forward collision assist system (FCW/AEB/AEBP) functions are enabled, if the indicator remains on, it indicates the system is not able to function normally. Please contact a local MG Authorised Repairer as soon as possible.

For more information, please refer to “Forward Collision Warning System (FCW)” and “Automatic Emergency Braking System (AEB) and Automatic Emergency Braking System for Pedestrians (AEBP)” in “Starting & Driving” section.

## **Manual Speed Assist System Indicator - Green/Yellow**



This lamp will illuminate yellow when the Manual Speed Assist function is enabled, the lamp will extinguish when the function is disabled. For specific operation, please refer to “Speed Assist System (SAS)” in “Starting & Driving” section. If the current speed of the vehicle is above the maximum value allowed by the system the vehicle remains in the stand by state and the lamp will illuminate yellow.

This lamp illuminates green when the Manual Speed Assist function is activated.

If the Manual Speed Assist System is not able to function normally the lamp will flash yellow and then extinguish.

Please try to reinstate this function. If this function cannot be switched on, please contact a local MG Authorised Repairer as soon as possible.

For more information, please refer to “Speed Assist System (SAS)” in “Starting & Driving” section.

## **Intelligent Speed Assist System Indicator - Green/Yellow**



This lamp will illuminate yellow when the Intelligent Speed Assist function is enabled, the lamp will extinguish when the function is disabled.

This lamp illuminates green when the Intelligent Speed Assist function is activated.

If the Intelligent Speed Assist System is not able to function normally the lamp will flash yellow and then extinguish. Please try to reinstate this function. If this function cannot be switched on, please contact a local MG Authorised Repairer as soon as possible.

For more information, please refer to “Speed Assist System (SAS)” in “Starting & Driving” section.

## **Manual Speed Assist System Speed Indicator**



This lamp will illuminate when the Manual Speed Assist function is enabled. 'NNN' denotes the current setting value of the speed limit. If there is no speed limit value the lamp will display ' — '.

## **Speed Limit Sign Indicator - Red**



'NNN' denotes the speed value of speed limit sign currently recognised. If there is no speed limit value available the lamp will display ' — '.

When the Intelligent Speed Assist function is activated or SLIF Warning function is enabled, the lamp will flash if the speed limit value is exceeded, please slow down.

# INSTRUMENTS AND CONTROLS

---

## Speed Limit Sign Additional Information Warning Lamp- Yellow



This lamp will illuminate when the speed limit sign currently recognised has additional information. Please pay attention to it.

## National Speed Limit Sign Indicator



When the national speed limit sign is identified, and the speed limit information function or intelligent speed assist function is enabled, this lamp illuminates.

For more information, please refer to “Speed Assist System (SAS)” in “Starting & Driving” section.

## Adaptive Cruise Control System Indicator - Yellow/Green \*



If the Adaptive Cruise function is enabled, the Adaptive Cruise Control System will enter the standby state, the lamp illuminates yellow.

When the Adaptive Cruise Control System operates, the lamp will illuminate green, this indicates that the Adaptive Cruise Control System is activated.

## Adaptive Cruise Control System Malfunction Indicator Lamp - Yellow \*



This lamp will illuminate if a Adaptive Cruise Control System failure is detected. Please contact a local MG Authorised Repairer as soon as possible.

## Rear Drive Assist System Indicator -Yellow



If the rear drive assist system is turned off, this lamp illuminates with prompt messages.

If the rear driver assist sensors are obscured, this lamp illuminates with prompt messages.

When rear drive assist system has a failure, this lamp illuminates with prompt messages. Please contact a local MG Authorised Repairer as soon as possible.

Refer to “Rear Driver Assistance System” in “Starting and Driving” chapter for more information.

## eCall SOS Indicator - Red/Yellow/Green



If the system is ready and an emergency services call (eCall) is in progress, the indicator illuminates green.

If the system is still capable of sending out a vehicle information message to the call centre, but other eCall capabilities are limited due to a fault in the system, the indicator will illuminate yellow. If the eCall system has

failed and not operational, the indicator illuminates red. If the yellow or red indicator is illuminated permanently after system self-test, please contact a local MG Authorised Repairer immediately.

## Particulate Filter Warning Lamp - Yellow



When this lamp illuminates yellow, it indicates that the particulate filter requires regeneration. Please drive the vehicle above 45 mph until the light is no longer illuminated, and then normal usage can be resumed.

When this lamp flashes, it indicates that the particulate filter is full. Please contact a local MG Authorised Repairer immediately. Please note if the warning is ignored, the vehicle will enter a reduced performance mode and may subsequently be immobilised.

Please refer to “Catalytic Converter and Particulate Filter” in “Starting & Driving” section.

# INSTRUMENTS AND CONTROLS

---

## Lights and Switches

### Master Light Switch

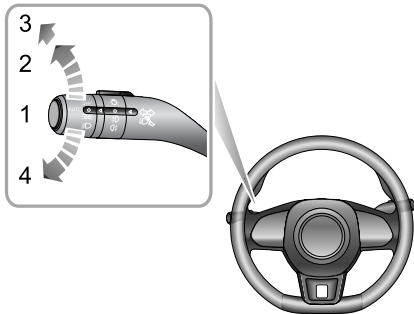

- 1 AUTO Lamp
- 2 Side Lamp/Switch Backlights
- 3 Headlamp
- 4 Light Off

### AUTO Lamp

When the start/stop switch is in the ACC position, the auto lighting system defaults to the ON position (1). The AUTO lighting system will automatically switch the side lamps and switch illumination on and off according to the intensity of current ambient light.

With the start/stop switch in the ON/RUNNING position, the AUTO lighting system will automatically switch the side lamps, switch illumination and dipped beam headlamps on and off according to the intensity of current ambient light.

**Note:** This function uses a light sensor that monitors exterior ambient light levels. The sensor for some models is fitted centrally to the fascia panel near the windscreen. **DO NOT** mask or cover this area. Failure to adhere to this may result in headlamps operating when not necessary.

### Side Lamp and Switch Illumination

Turn the master lighting switch to position 2 to operate the side lamps and switch illumination. With the start/stop switch in the OFF position if the lighting switch is in



position 2 and the driver's door opened an audible warning will sound to alert the driver, the side lamps will remain on. The message centre will prompt "Lights On" (model dependant).

## **Dipped Headlamps**

When the start/stop switch is in the ON/RUNNING position turn the master lighting switch to position 3 to operate the dipped beam headlamps , side lamps and switch illumination.

## **Lights Off**

Turn the master lighting switch to position 4, this will switch off all lamps, releasing the switch will allow it to return to the AUTO switch position.

## **Daytime Running Lamps**

The daytime running lamps turn on automatically when the start/stop switch is in position ON/RUNNING. When the side lamps are switched on, the daytime running lamps extinguish automatically.

## **Welcome Light**

When the car is unlocked, the system will automatically enable the welcome light function according to the intensity of the current ambient light. The daytime mode will illuminate the side lamps, while the night mode will illuminate the dipped beams, side lamps and puddle lamps \*.

## **Follow Me Home**

After the start/stop switch is turned off, pull the lighting lever towards the steering wheel. Follow Me Home function is enabled. Dipped beams and side lamps will illuminate. Follow Me Home can be set through "Car" on the infotainment display.

## **Find My Car**

After the vehicle has been left in a locked condition in several minutes, pressing the lock button again on the remote key will enable the Find My Car function. This function will identify the car by means of an audible and visual alert. Pressing the Lock button on the remote key again will suspend this operation. At this time, press the

# INSTRUMENTS AND CONTROLS

Unlock button on the remote key will cancel this operation. Find My Car can be set through “Car” on the infotainment display.

## Headlamp Levelling Adjustment

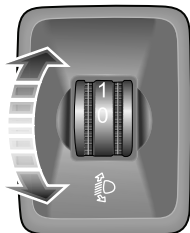

Position 0 is the initial position of the headlamp levelling adjustment switch. The headlamp levelling can be adjusted as per the following table according to the vehicle load.

Location	Load
0	Driver, or driver & front passenger
1	All the seats occupied with no load
2	All the seats occupied plus an evenly distributed load in the boot
3	Driver only, plus an evenly distributed load in the boot

## Lighting Lever Switch



**Take care not to dazzle oncoming vehicles when driving using main beam headlamps.**

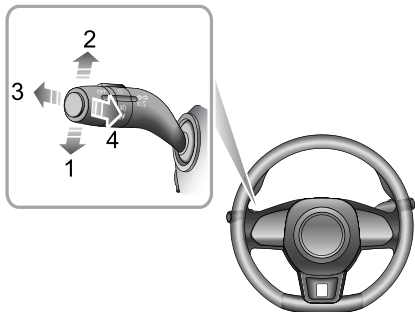

## Direction Indicators

Move the lever down to indicate a LEFT turn (1). Move the lever up to indicate a Right turn (2). The corresponding

GREEN indicator lamp in the instrument pack will flash when the turn signal lamps are working.

Rotating the steering wheel will cancel the indicator operation (small movements of the steering wheel may not operate the self cancelling). To indicate a lane change, move the lever briefly and release, the indicators will flash three times and then cancel.

## Main/Dipped Beam Headlamps Switching

With the start/stop switch in the ON/RUNNING position and the master lighting switch turned to position 3, or the auto function has switched the lights on, push the lever (3) towards the instrument panel to turn the headlamp high beams on. The high beam indicator lamp in the instrument pack will illuminate, press the lever (3) again to switch the headlamps to low beam.

## Main Beam Flash

To briefly flash the main beam on and off, pull the lever (4) towards the steering wheel and then release.

# INSTRUMENTS AND CONTROLS

---

## Smart Main Beam System



*Smart main beam system serves only as an auxiliary function. The driver still needs to check the status of the front lamps, and turn on the front lamps when necessary.*

*For example: The main beam may not be turned off automatically in the following cases, thus the manual switching between the main beam and dipped beam is required:*

- The windscreen is dirty, broken or obstructed by other objects blocking the view of the sensor.*
- The lamps of other vehicles are missing, damaged, blocked or partially blocked or cannot be detected for some other reasons.*
- The lamps of other vehicles are obscured or partially obscured by smoke, fog, snow, water spray or any other conditions that effect visibility.*

- When pedestrians, non-motor vehicles and other objects with no obvious light or reflected light are encountered.*
- When the headlamps and tail lamps of other vehicles cannot be detected due to the sensor view is impaired due undulating road conditions such as bends, dips or hills.*
- When the car is driving on the winding road or mountainous road.*

*In cases of any of the above conditions (but not limited to) smart main beam operation may be suspended, it may be necessary to operate the main beam lamps manually.*

The smart main beam system uses the front view camera to detect the light intensity of the vehicle ahead. The main beam lamps can be switched on or off automatically by the system when the surroundings are dark and no light detected.

To enable the smart main beam system, the following conditions should be met:

- 1 The master lighting switch must be in the 'Auto' position and the dipped beam lamps switched on via automatic control.
- 2 The vehicle is running and the speed is above 25mph (40km/h)
- 3 The front/ rear fog lamps are NOT switched on.

When the smart main beam system is enabled, the auto main beam indicator on the instrument pack illuminates.

The main beam lamps will remain on under automatic control until any of the following conditions occur:

- The system detects the headlamps of approaching vehicles.
- The system detects the tail lamps of vehicles ahead.
- The surroundings become bright enough not to require main beam.
- The vehicle speed drops below the 25mph (40 km/h) threshold.

The system will temporarily suspend the smart main beam function once the following conditions are met:

With the smart main beam system enabled, instantaneously pull the lighting lever towards the steering wheel, the smart main beam function will be temporarily suspended, it will automatically be re-instated when the switch lever is released.

**Note: Continuously operating the main beam switch within 2 seconds will retain the main beam lamps under automatic control, and the system will not exit the smart main beam function.**

## IMPORTANT

The smart main beam function uses data from the front view camera, always keep the windscreen clean and free from residue in this area to maintain optimum performance of this system. Any damage in this area, such as stonechips must be repaired at the earliest convenience.

# INSTRUMENTS AND CONTROLS

## Fog Lamp Switch



*Fog lights should only be used when visibility is below 100m - other road users could be dazzled in clear conditions.*

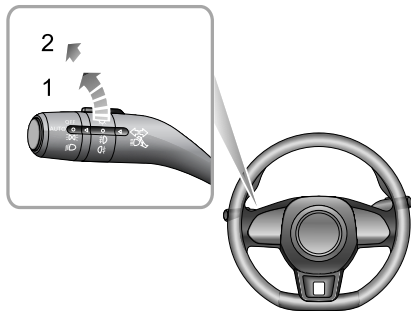

## Front Fog Lamps

With the start/stop switch in the ON/RUNNING position and the side lamps on, turn the fog lamp switch to position

1 to turn on the front fog lamps. The indicator illuminates in the instrument panel when the front fog lamps are on.

## Rear Fog Lamps

With the start/stop switch in the ON/RUNNING position and the front fog lamps turned on, turn the fog lamp button to position 2 to turn on the rear fog lamps, release the button to return to position 1. The indicator illuminates on the instrument panel when the rear fog lamps are on.

## Hazard Warning Lamps

Press the hazard warning lamp button  to operate the hazard warning lamps. All turn signal lamps and direction indicator lamps will flash together. Press the button again to switch off the hazard warning lamp. All turn signal lamps and direction indicator lamps will stop flashing. For the location of hazard warning lamp, refer to the illustration of "Hazard Warning Devices" under "Emergency Information".

## Wipers and Washers

### Front Windscreen Wiper Controls

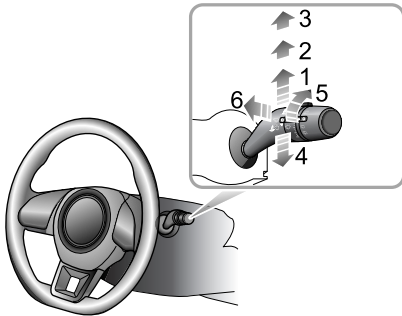

The wipers and washers will only operate when the start/stop switch is in position "ON/RUNNING". Operate the lever to select different wiping modes:

- Intermittent wipe (1)
- Slow speed wipe (2)
- Fast speed wipe (3)

- Single wipe (4)
- Intermittent wipe interval adjustment \*/Rain sensor sensitivity adjustment \* (5)
- Programmed wipe (6)

### Intermittent Wipe

By pushing the lever up to the Intermittent wipe position (1), the wipers will operate automatically. The interval between the Intermittent wipes can be increased/decreased via the switch (5). This interval will also change with the vehicle speed. As the vehicle speed increases, the wiping interval decreases. As the vehicle speed decreases, the wiping interval increases.

Some models are equipped with a rain sensor fitted to the interior rearview mirror base to detect varying amounts of water on the outside of the windscreen. With automatic wipe, the vehicle will adjust the wiping speed according to the signals provided by rain sensor. Turn the switch (5) to adjust the sensitivity of rain sensor. As the sensitivity increases, the wiping interval decreases.

**Note:** *Immediately operating the wiper one time can be achieved by increasing the sensitivity of rain sensor.*

# INSTRUMENTS AND CONTROLS

---

*If the rain sensor detects continuous rainwater, the wiper will keep working. When it is not raining, it is recommended to switch off automatic wipe.*

## Slow Speed Wipe

By pushing the lever up to the slow speed wiping position (2), the wipers will operate slowly.

## Fast Speed Wipe

By pushing the lever up to the fast speed wiping position (3), the wipers will operate at fast speed.

## Single Wipe

Pressing the lever down to the single wiping position (4) and releasing will operate a single wipe. If the lever is held down (4), the wipers will operate continuously until the lever is released.

**Note:** *When the car is stationary, if the bonnet is opened, the front wiper/washer operation will be disabled.*

### IMPORTANT

- Avoid operating the wipers on a dry windscreen.
- In freezing or extremely hot conditions, make sure that the wiper blades are not frozen or adhered to the windscreen.
- In winter, remove snow or ice from around the wiper arms and blades, including the wiped area of the screen.

## Programmed Wipe

Pulling the lever toward the steering wheel (6) will operate the front windscreen washers. After a short delay, the wipers will commence operating in conjunction with the washers.

**Note:** *The wipers continue operating for a further three wipes after the lever is released. After several seconds, there will be a further wipe to remove any fluid draining down the screen.*



## IMPORTANT

If the washers fail to deliver the screen wash solution (dirt or ice may have blocked the jets), release the lever immediately. This will prevent the wipers from operating, and the consequent risk of visibility being impaired by dirt smearing across the unwashed windscreen.

## Rear Windscreen Wiper Controls

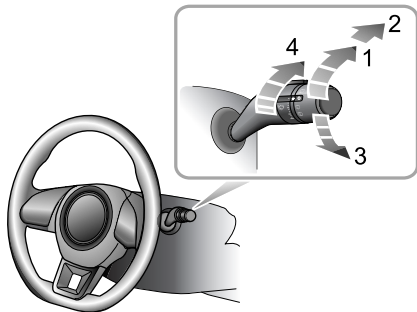

The rear wipers and washers will only operate when the start/stop switch is in the "ON/RUNNING" position. Operate the lever to select different wiping modes:

- Intermittent wipe (1)
- Wash and wipe (2)
- Wash and wipe (3)
- Wipe interval adjustment (4)

# INSTRUMENTS AND CONTROLS

---

## Intermittent position

If the rear wiper switch is turned to intermittent wipe (1), the rear wiper will operate. It will complete 3 continuous wipes before changing to intermittent mode. The time period between the wipes can be increased/decreased via the switch (4).

## Wash and wipe

Turn the rear window wiper switch to wash and wipe (2) position and hold, the rear window wiper and washer will operate, the rear window wiper wipes quickly. release the switch allowing it to return to intermittent wipe (1), the rear window washer will stop operating.

Turn the rear window wiper switch to wash and wipe (3) and hold, the rear window wiper and washer will operate. release the switch allowing it to return to OFF position, the rear window washer will stop operating, and the rear window wiper wipes for 3 times, after several seconds, the wiper will wipe once more to remove the washer fluid on the windscreen.

**Note:** *When the tailgate is opened, rear wiper operations will be disabled.*

**Note:** *When the windscreen wipers are switched on, if Reverse gear is selected , the rear window wiper will operate.*

## Steering System

### Adjustment of Steering Column



**DO NOT attempt to adjust the height or angle of the steering column while the car is in motion. This is extremely dangerous.**

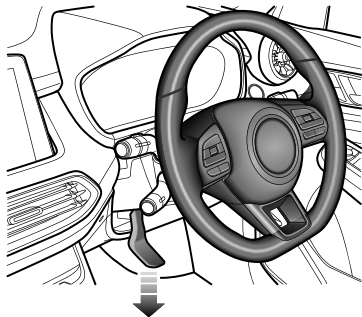

To adjust the angle or height of the steering column to suit your driving position:

- 1 Fully release the locking lever.
- 2 Hold the steering wheel in both hands and tilt the steering column up or down to move the wheel into the most comfortable position.
- 3 Push or pull the steering wheel towards or away from the body.
- 4 Once a comfortable driving position has been selected, pull the locking lever fully up to lock the steering column into its new position.

# INSTRUMENTS AND CONTROLS

---

## Electric Power Steering



***If the electric power steering fails or cannot operate the steering will appear very heavy, this will effect driving safety.***

The electric power steering system only works when the vehicle is started. The system operates via a motor with assistance levels automatically adjusted based on vehicle speed, steering wheel torque and steering wheel angle.

### IMPORTANT

Holding the steering wheel on full lock for long periods will result in a reduction in power assistance causing a heavier feel to the steering for a short period of time.

## Steering Mode Switching\*

The electric power steering system provides 3 different steering modes , please refer to "Driving Mode" in the "Starting & Driving" section.

1 Normal: provides moderate power assistance.

- 2 Comfort: provides a high level of assistance, with a light feel.
- 3 Sport: provides low level power assistance, with a heavier feel.

***Note: Steering mode selection is only available when the steering wheel is not being turned. Any changes made in this state will not take effect until the steering wheel is straight ahead.***

## Electric Power Steering (EPS) Warning Lamps

See "Warning Lights and Indicators" under the "Instruments and Controls" section.

If the battery has been disconnected for any reason, upon reconnection the warning lamp will illuminate yellow. Movement of the steering wheel from lock to lock will initialise the system and the lamp will extinguish.

### Horn



Press the horn button area on the steering wheel (as indicated by the arrow) to operate the horn.

**Note:** *The vehicle horn press and the driver's airbag are located in close proximity on the steering wheel. The illustration shows the position of the horn (indicated by arrow), please ensure that you press*

*in this area to avoid any potential conflict with the operation of the airbag.*

#### IMPORTANT

To avoid possible SRS issues, please do not press with excessive force or hit the airbag cover when operating the horn.

# INSTRUMENTS AND CONTROLS

---

## Rearview Mirrors

The vehicle is fitted with rear view mirrors, these consist of a door mirror fitted to each door and a centrally mounted interior mirror. Rear view mirrors reflect situations behind or on both sides of the vehicle thus expanding the driver's field of vision.

The rearview mirrors are safety-critical parts. Proper use and reasonable mirror angle adjustment can improve the driver's driving safety and comfort.

## Exterior Door Mirrors

**Note:** *Objects viewed in exterior door mirrors may appear further away than they actually are.*

The mirrors can be folded back electrically towards the side windows into a 'park' position to enable the car to negotiate narrow openings and avoid collisions.

In addition to the folding function, the mirror angle of the exterior door mirrors can be electrically adjusted.

## Mirror Glass Heating

The door mirrors have integral heating elements which disperse ice or mist from the glass. The heating elements operate while the Heated Rear Window  is switched on.

**Note:** *The heating elements of rear window and mirror will only work when the engine is running.*

## Power Folding

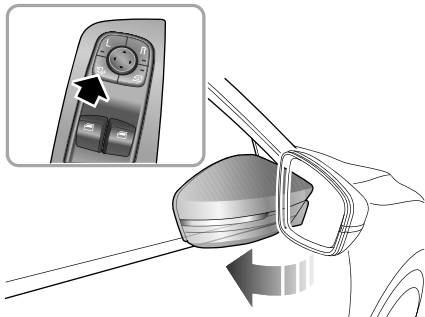

Pressing the switch (arrowed) on the combination switch in the driver side switch panel will electrically fold the exterior door mirrors. Pressing this switch again will restore the mirrors to their original position.

While unlocking/locking the vehicle, the exterior door mirrors will be deployed/folded automatically. This function can be set in the relevant interface on the infotainment display.

**Note:** *Electrical folding door mirrors that have been moved from their positions by manual or accidental means must be reset by operating the folding switch to completely fold and unfold the mirrors one time.*

### Electric Adjustment of Mirror Glass

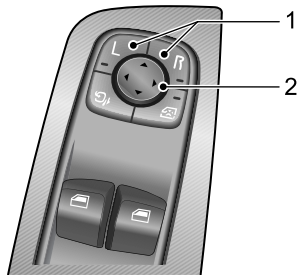

- Press the left (L) or right (R) switch (1) to select the left or right exterior door mirror. The indicator lamps within the switches (1) will illuminate when selected.
- Press one of the 4 arrows of the circular switch (2) to adjust the angle of the exterior door mirror.
- Press the L or R switch (1) again, the corresponding indicator lamp will extinguish, and the mirror

## INSTRUMENTS AND CONTROLS

---

adjustment operation will be stopped. This is to avoid accidental adjustment of mirror angle once adjustments has been made.

### IMPORTANT

- Exterior door mirrors are operated by electrical motors. Operating them directly by hand may damage the internal components.
- Washing or flushing exterior door mirrors with high pressure water jets or car washes may result in electrical motor failure.

### Puddle Lamp \*

Puddle lamps are located within the lower half of the door mirrors. For information on how to operate these puddle lamps please refer to "Lighting and Switches" in "Instruments and Controls" chapter.

### Automatic Anti-dazzle Interior Rearview Mirror



When the START/STOP Switch is in the ON/RUNNING position, the automatic anti-dazzle function is switched on automatically. When a following vehicle's headlamps could dazzle the driver, the light sensor activates the anti-dazzle function.

The automatic anti-dazzle function can be inhibited if:

- The light from the vehicle behind is not seen by the light sensor on the mirror.
- Reverse gear is selected.



*Note: Attaching film or objects on the rear window may have influences on the function of the automatic anti-dazzle function.*

# INSTRUMENTS AND CONTROLS

## Sunvisor



**The vanity mirror on the driver side should only be used when the car is stationary.**

Sunvisor (1) and vanity mirrors (2) are arranged on the roof ahead of both the driver and the front passenger. Certain models are fitted with vanity mirror lights (4) depending on the vehicle configuration.

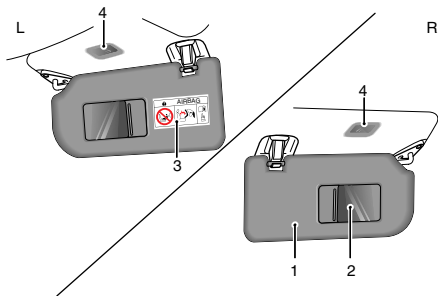

Pull the sunvisor downward to use the vanity mirror. If the roof has vanity mirror lights, the vanity mirror light is switched on when the cover is opened, and it is switched off when the cover is closed.

**Note: Warnings and instructions on the use of a child restraint (3) are attached to both sides of the passenger sunvisor.**

**NEVER use a rearward facing child restraints on a seat protected by an ACTIVE AIRBAG in front of it, DEATH or SERIOUS INJURY to the CHILD can occur. Refer to 'Disabling the Passenger Airbag'.**

## Windows

### Power Operated Window Switch

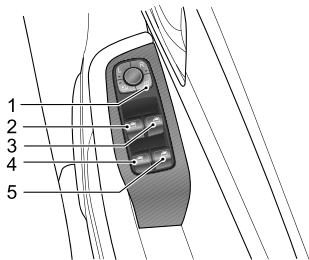

- 1 Rear Window Isolation Switch
- 2 Front Left Window Switch
- 3 Front Right Window Switch
- 4 Rear Left Window Switch
- 5 Rear Right Window Switch

### Window Operation



*Ensure children are kept clear when raising or lowering a window. Improper use or activation of the electric windows by children could cause serious harm or even death. It is the responsibility of the driver and adult passengers to ensure that when carrying children the necessary steps are taken to isolate the window operation. This should include switching off the ignition and removing the smart key from the vehicle when children are left alone in the vehicle.*

Press the switch (2 ~ 5) to lower the window, and pull the switch to raise the window. Release the switch, the window will stop moving (unless in "one-touch" mode).

**Note:** *The front and rear passenger windows can also be operated by individual window switches, mounted on each door. The rear window switches will not function if the rear window isolation switch on the driver door has been activated.*

# INSTRUMENTS AND CONTROLS

---

**Note:** *When the start/stop switch is in the ACC or ON/RUNNING position, the power windows can be operated (doors should be closed).*

## Rear Window Isolation Switch

Press the switch (1) to isolate the rear window controls (an indicator lamp in the switch illuminates), and press again to restore control.

**Note:** *It is recommended that you ISOLATE the rear window switches when carrying children.*

## One Touch Down

The window switches (2 ~ 5) are 2 stage switches, short press to the second stage, the window will enter one touch mode and automatically fully open. When the window is moving down, its movement can be stopped at any time by pressing the switch again.

## One Touch Up with Anti-Trap

Some window switches have the One Touch Up function. Briefly pull up the window control switch (2) to the second

stage, the corresponding window automatically ascends to fully closed. Window movement can be stopped at any time by operating the switch again.

The 'Anti-Trap' function is a safety feature which prevents the window from fully closing if an obstruction is sensed. In this case, the window will move down so that the obstacle can be taken out.

**Note:** *DO NOT operate the power window controls continuously several times in a short time frame, in some cases the power window controls may be disabled to protect the motor. If this occurs, please wait a few seconds until the motor cools down.*

**Note:** *If the battery is cut off during lifting and lowering of the window, One Touch Up and Anti-Trap mode may be not operational, in this case, fully open the window, then raise the window to the fully closed position by lifting the switch briefly and consecutively. When the window is fully closed, hold the switch in the close position for a further 5 seconds . One Touch Up and Anti-Trap mode will be resumed.*

## **"Lazy Lock" Function \***

The "Lazy Lock" function can open or close all the windows by using the remote key from outside the vehicle as long as it is within detection range.

Press and hold the remote key unlock button until the windows start to open, release the unlock button, all windows will open fully. With the windows open, press and hold the remote key lock button until the windows start to close, release the lock button, the windows will completely close.

# INSTRUMENTS AND CONTROLS

## Sunroof \*

### Instructions



**DO NOT allow passengers to lean out of an open sunroof whilst the vehicle is in motion. Injuries may occur from objects such as tree branches.**

- Avoid fully opening the sunroof during rain showers.
- It is advised not to open the sunroof at high speeds.
- Where possible, please clean any residual water or raindrops off the sunroof prior to opening. Failure to do so may result in water entering the car.
- DO NOT use abrasive materials to clean the sunroof glass. Use alcohol based solvent.
- DO NOT hold the operating switch in the open/close position for any length of time after operation is complete, this could damage the electrical components.
- Clean the sunroof regularly to maintain operation and performance. Visit an MG Authorised Repairer for service as required.

### Sunroof Operation



**Safety of the vehicle occupants must be observed at all times. DO NOT allow limbs to be placed in the moving path of the sunroof at any time, injury may occur.**

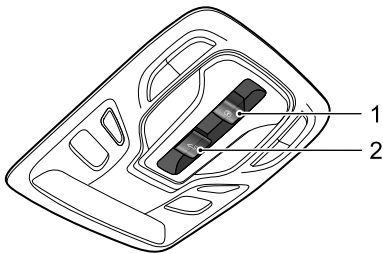

When the START/STOP Switch is set to ACC or ON/RUNNING, you can operate the sunroof.

The sunroof consists two pieces of glass and one sunshade. The front glass can be opened by sliding or tilting, the rear one is fixed and cannot be opened, and the sunshade

can slide open. Switch 1 is used to operate the sunroof sunshade, and switch 2 is used to operate the sunroof glass. The method by which the sunroof will open function is identified by the icons on the switches.

## Sunroof Glass Operation

### *Open the Sunroof Glass by Tilting*

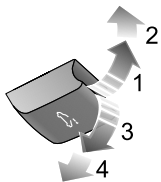

Push the sunroof glass switch upward to the 1st position (1) and hold, the sunroof will automatically tilt open. You can stop the movement of the sunroof at any time by releasing the switch. Push the glass switch with slightly harder force to move the switch to its 2nd position (2) and then release, the sunroof will automatically open completely.

### *Close the Sunroof Glass by Tilting*

Pull the sunroof glass switch downward to the 1st position (3) and hold, the sunroof will automatically close. You can stop the movement of the sunroof at any time by releasing the switch. Pull the glass switch with slightly harder force to move the switch to its 2nd position (4) and then release, the sunroof will automatically close completely.

### *Close the Sunroof Glass by Sliding*

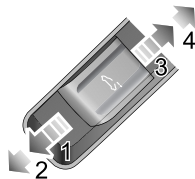

Push the sunroof glass switch forward to the 1st position (1) and hold, the sunroof will automatically close. You can stop the movement of the sunroof at any time by releasing the switch. Push the glass switch forward with slightly harder force to move the switch to its 2nd position (2)

## INSTRUMENTS AND CONTROLS

---

and then release, the sunroof will automatically fully close. You can stop the movement of the sunroof at any time by pushing the switch forward again.

### ***Open the Sunroof Glass by Sliding***

Push the sunroof glass switch backward to the 1st position (3) and hold, the sunroof will automatically slide open. You can stop the movement of the sunroof at any time by releasing the switch. Push the glass switch backward with slightly harder force to move the switch to its 2nd position (4) and then release, the sunroof will automatically open fully. You can stop the movement of the sunroof at any time by pushing the switch backward again.

### **Sunroof Sunshade Operation**

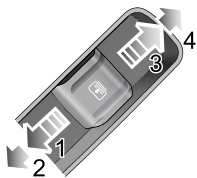

### ***Open the Sunshade***

Push the sunroof sunshade switch backward to the 1st position (3) and hold, the sunshade will automatically slide open. You can stop the movement of the sunshade at any time by releasing the switch. Push the sunshade switch backward with slightly harder force to move the switch to its 2nd position (4) and then release, the sunshade will automatically open fully. You can stop the movement of the sunshade at any time by pushing the switch backward again.



## **Close the Sunshade**

Push the sunroof sunshade switch forward to the 1st position (1) and hold, the sunshade will automatically close. You can stop the movement of the sunshade at any time by releasing the switch. Push the sunshade switch forward with slightly harder force to move the switch to its 2nd position (2) and then release, the sunshade will automatically fully close. You can stop the movement of the sunshade at any time by pushing the switch forward again.

**Note: If the vehicle is to be parked in direct sunlight for a length of time it is recommended that the sunshade be closed to protect the interior trim components from damage, and to help regulate the in car temperatures.**

## **Anti-pinch Function**

The sunroof and sunshade feature an “Anti-Pinch” function, this is a safety feature which prevents the sunroof or sunshade from fully closing whilst in the automatic mode if an obstruction is sensed - if this happens the sunroof/sunshade will open slightly to allow the obstruction to be removed.

## **Forcibly Closing the Sunroof (over-riding the anti pinch)**

To forcibly close the sunroof glass after an anti-pinch intervention, gently slide the glass switch forwards to the 1st position within 5 seconds and hold in position until the sunroof glass is fully closed.

**Note: The anti pinch function is suspended during this operation.**

## **Forcibly Closing the Sunshade(over-riding the anti pinch)**

To forcibly close the sunshade that has reopened due to activation of anti-pinch function: gently slide the sunshade switch forwards to the 1st position within 5 seconds and hold it until the sunshade closes fully.

**Note: The anti pinch function is suspended during this operation.**

# INSTRUMENTS AND CONTROLS

---

## Linkage between Sunshade and Sunroof Glass

To prevent the sunshade from being exposed, the sunshade will move together with the sunroof glass as one unit when the sunroof is opened. To close the sunshade, please close the sunroof glass first.

## Initialization of Sunroof

In the event of a power failure or battery disconnection when the sunroof glass or sunshade is in motion, the sunroof/sunshade will require initialisation when the power is restored.

To carry out the sunroof glass initialisation operation:

Fully close the glass -gently slide the switch forward to the 2nd position and hold in position for 10 seconds. The sunroof will open a preset amount and stop, it will then close automatically - the sunroof glass is then initialised. During the whole process, the switch must remain in the 2nd position.

To carry out the sunshade initialisation operation:

Fully close the sunshade -slide the close switch forward to the 2nd position and hold in position for 10 seconds.

The sunshade will open a preset amount and stop, it will then close automatically - the sunshade is then initialised. During the whole process, the switch must remain in the 2nd position.

## Thermal Protection

To prevent the sunroof glass motor and the sunshade motor from being overheated and damaged, the motors are designed with a thermal protection function, any opening or closing operation whilst in the thermal protection state will not move the sunroof. After the motor has cooled down and exits the thermal protection state, the sunroof can be operated until the next thermal protection event.

## "Lazy Lock" Function

"Lazy Lock" function can open or close the sunroof from outside the vehicle.

Press and hold the remote key unlock button for several seconds until the sunroof glass and sunshade start to open, then release the button, the sunroof will continue to open until it is fully opened; with the sunroof open, press and

hold the remote key lock button for several seconds until the sunroof glass and sunshade start to close, then release the button, the sunroof will continue to close until it is fully closed.

# INSTRUMENTS AND CONTROLS

## Interior Light

### Front Interior Lamp

According to different configurations of the vehicles, the front interior lamp may feature bulb or LED configurations.

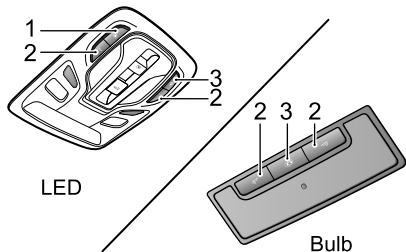

- 1 Main Manual Control Switch of Front/Rear Interior Lamps
- 2 Manual Control Button of Corresponding Front Interior Lamp
- 3 Automatic Control Button

Press the switch 1 to turn on the front and rear interior lamps, press again to turn off.

Press either of the buttons 2 to turn on a corresponding front interior lamp, press again to turn off.

In addition to the above manual control of interior lamps, in some conditions the vehicle features an automatic control function. Press the button 3 to turn on automatic control, press again to release the button, and turn off the automatic function.

When the automatic control function is enabled, the front and rear interior lamps illuminate automatically if any of the following actions are carried out:

- The car is unlocked.
- Any door is opened.
- When the vehicle light sensor detects that the ambient light level is low or the side lights have been illuminated within 30 seconds, the interior light will operate when the START/STOP Switch is set to OFF.

**Note:** *If a door is open for more than 15 minutes, the interior lamps will be switched off automatically to avoid battery drain.*

## Rear Interior Lamp \*

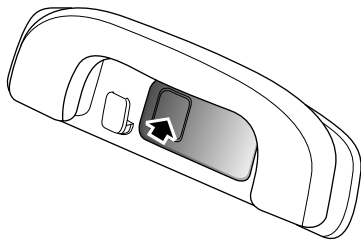

Vehicles equipped with LED front interior lamp are equipped with LED rear interior lamps.

The rear courtesy lights are located on the left and right sides of interior roof panel. Press the lamp lens as indicated in the diagram to switch on the rear courtesy lights, press it again to switch off the lights.

## Ambient Lamps \*

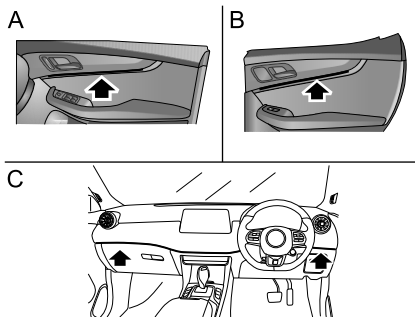

Ambient lamps are fitted on certain models to create a comfortable atmosphere inside the car. The control of the ambient lamps can be set in the infotainment system. Ambient lamps are provided on the front door interior trim panel (A), rear door interior trim panel (B) and fascia panel (C).

# INSTRUMENTS AND CONTROLS

## Power Socket



*Please ensure the socket lid is inserted when the 12V power socket is not in use. This will ensure no debris or foreign objects enter the socket preventing its use or cause short circuits.*



*The voltage of the 12V power socket is 12 volt, and the power rating is 120 watt, please DO NOT use the electrical appliance with its power exceeding the rating.*



*Extended use of the accessory power socket and USB socket when the engine is switched off will cause premature discharging of the vehicle battery.*

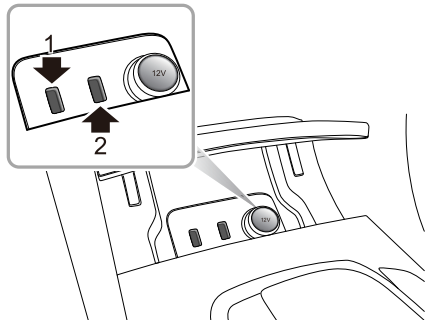

The 12V front power socket is located in the front of the centre console. When the START/STOP Switch is in the ACC/ON/RUNNING position, remove the socket lid, it can then be used as a power supply.

There are two USB ports (1 and 2) located at the left side of 12V front power socket, the USB ports can provide 5V voltage when serving as the power outlet, and can be used for data transmission.

There are also two USB ports located at the rear of the centre console, these provide 5V voltage when serving as the power outlet.

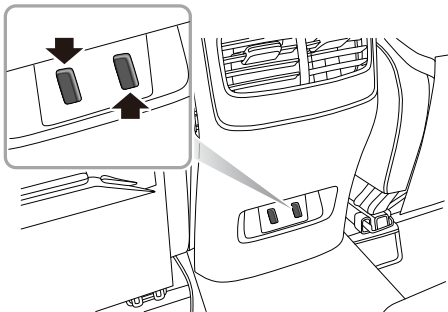

**Note: No cigarette lighter is available on the vehicle.  
If required, please seek an MG Authorised Repairer.**

# INSTRUMENTS AND CONTROLS

---

## Storage Devices

### Instructions

- Please close all storage devices when the car is in motion. Leaving these storage devices open may cause personal injuries in cases of a sudden start-off, emergency braking and a car accident.
- Do not place flammable materials such as liquid or lighters in any storage devices. The temperature in hot conditions may ignite flammable materials and lead to a fire.

### Glove Box

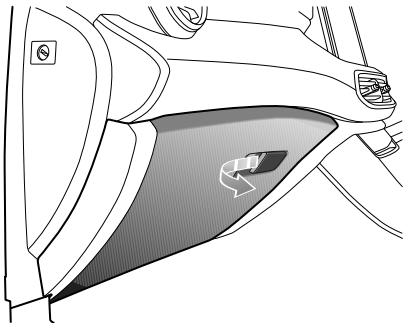

To open the glove box, pull the handle on the glove box cover (as indicated by the arrow). The glove box light will automatically illuminate.

Push the lid forward to close the glove box. Make sure the glove box is fully closed when the car is driving.



## Storage Box – Driver Side

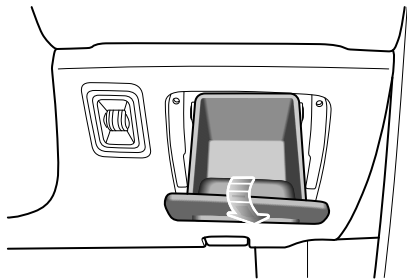

Located beneath the instrument panel on the driver side, pull the storage box lid down to open the box.

## Centre Console Armrest Box

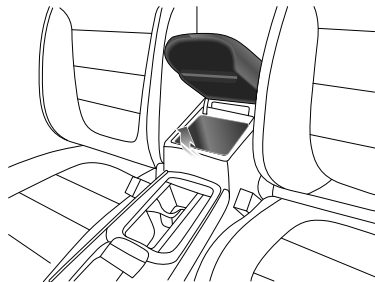

Lift the armrest (arrowed) to open the compartment cover. Put the cover down to close it.

# INSTRUMENTS AND CONTROLS

---

## Load Space Compartment



**DO NOT place articles on the luggage cover \* , they could move causing personal injury in the event of an accident, emergency braking or hard acceleration.**

Lift the loadspace carpet (2), fix it in place to the roof (A) with the attached hook. Place items safely in the loadspace storage compartment according to their sizes. After items are placed, lower the loadspace carpet, ensuring it is located correctly.

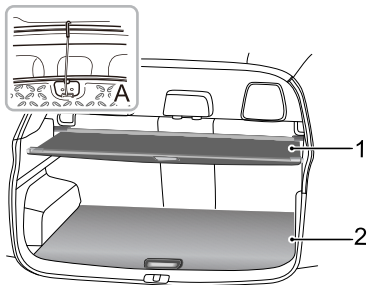

If you plan to use the loadspace storage compartment, firstly retract the luggage cover \* (1), move it along the groove until it is fully retracted.

## Cup Holder



*Do not place hot drinks in the cup holder whilst driving. Spillage may result in personal injury or damage.*

## Centre Console Cup Holder

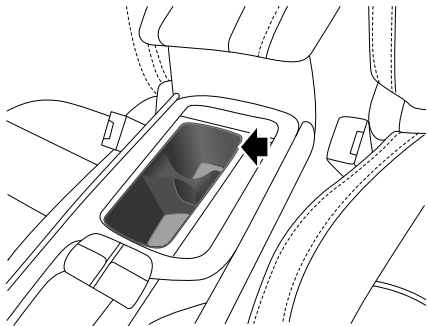

The centre console cup holder is situated at the front end of the centre console armrest assembly, and is used to hold a cup or beverage bottle.

## Rear Armrest and Rear Cup Holder

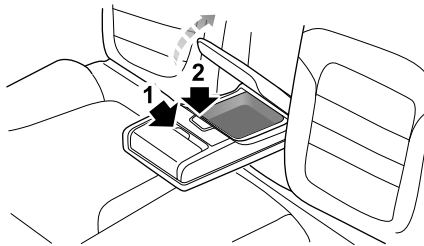

Fold forward to open the rear armrest. Press button 1 to open the cup holder. Press button 2 to open the storage box in the rear of the armrest.

# INSTRUMENTS AND CONTROLS

---

## Roof Luggage Rack \*



**Roof loads *MUST NOT* exceed the maximum authorised load. This may lead to injury or vehicle damage.**



**Loose or improperly fixed loads may fall from the roof luggage rack and lead to an accident or cause injury.**



**When heavy or large items are carried on the roof luggage rack it may lead to changes in steering, handling and braking characteristics. Please avoid sharp maneuvers, heavy braking and excessive acceleration.**

Pay attention to the following when using the roof luggage rack:

- Fix loads towards the front of the roof as far as possible, and distribute the roof load evenly.
- DO NOT use automatic car washes with loads on the roof luggage rack.

- The overall height of the car is different when loads are fitted to the roof luggage rack. Please ensure there is adequate clearance when entering tunnels and garages.
- Ensure the loads carried by the roof luggage rack do not impede operation of the sunroof, roof antenna or tailgate opening.
- When installing or removing a piece of loading equipment, follow the instructions provided by the manufacturer of the loading equipment.

### Maximum Authorised Load for the Roof

The maximum authorised load for the roof is 50 kg, and the roof load includes the weight of the roof loads and that of the loading equipment installed.

Be sure to know about the weight of loads, and weigh them when necessary. Never exceed the maximum authorised load for the roof.

### Periodical Check

Always check the condition of bolt connectors and fasteners before using the rack luggage rack. Periodically check the condition of bolt connectors and fasteners.

## ***Air Conditioning and Audio Systems***

---

72 *Ventilation*

75 *Electronic Temperature Control \**

80 *Automatic Temperature Control \**

86 *Infotainment System*

# AIR CONDITIONING AND AUDIO SYSTEMS

## Ventilation

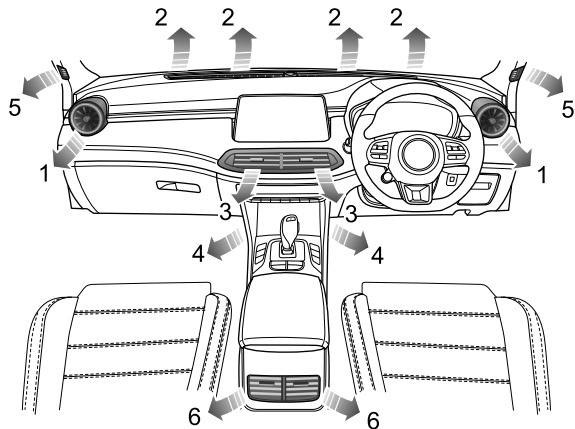

- 1 Side Vents
- 2 Windscreen/Defrost Vents
- 3 Centre Vent
- 4 Front Footwell Vents
- 5 Front Side Window Vents
- 6 Centre Console Vents

There are also 2 rear footwell vents, respectively on the floor under the front seats (not shown in the figure).

## AIR CONDITIONING AND AUDIO SYSTEMS

The heating, ventilation and air conditioning system provides fresh, cooling or heated air to the interior of the car. Fresh air is drawn in through the air intake grille under the front windscreen and the air conditioning filter.

Always keep the air intake grille clear of obstructions such as leaves, snow or ice.

### A/C Particle/Pollen Filter

The particle/pollen filter helps to keep the car interior free from pollen and dust. To remain fully effective, the filter should be replaced at the recommended service interval.

### Vents

#### Centre Vents

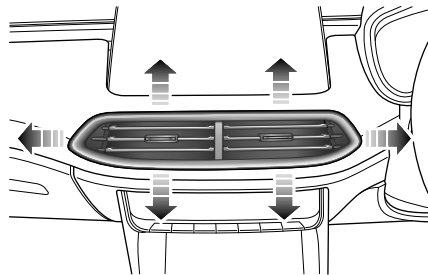

Slide the button in the centre of the louvres completely to the left or right to open or close the vent, adjust this button to direct the flow of air.

Toggle the button at the centre of each vent up and down, left and right to regulate the air direction.

# AIR CONDITIONING AND AUDIO SYSTEMS

---

## Side Vents

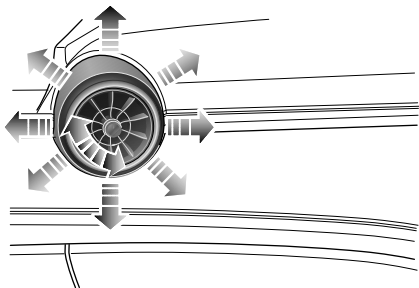

Rotate the centre thumb-wheel clockwise or anti-clockwise to open or close the vent. Toggle the centre thumb-wheel up, down, left or right to adjust the air direction.

## Centre Console Vents

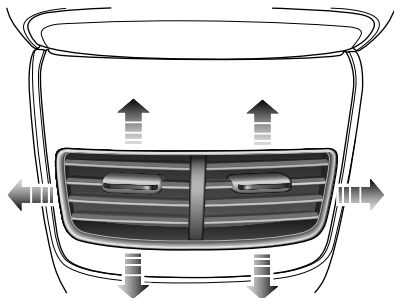

Slide the button in the centre of the louvres completely to the left or right to open or close the vent, adjust this button to direct the flow of air.

Toggle the button at the centre of each vent up and down, left and right to regulate the air direction.



## Electronic Temperature Control \*

### Infotainment Screen Control Interface

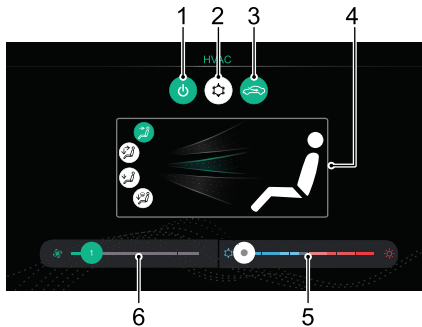

- 1 System On/Off
- 2 AC Cooling On/Off
- 3 Air Recirculation Mode
- 4 Air Distribution Mode
- 5 Temperature Control
- 6 Blower Speed Control

# AIR CONDITIONING AND AUDIO SYSTEMS

---

## System On/Off

Touch the System On/Off Button on the control interface to switch the system on, all functions will revert to the state before shutdown. Touch again to switch off.

**Note:** *Turning off the infotainment screen will not affect the operation of the AC system*

## AC Cooling On/Off

Touch the AC Cooling On/Off Touch Button to turn the AC cooling function ON/OFF.

**Note:**

- 1** *The cooling/heating mode of the air conditioning will only operate when the engine is running.*
- 2** *The heating function is still available, when the AC cooling is switched off.*
- 3** *A small amount of water may remain in the air conditioner after usage, this may produce a peculiar smell. If this is a particular issue, it is recommended to switch off the cooling function*

*and run the blower for a while with the engine running prior to switching off.*

## Air Recirculation Mode

Touch the recirculation button on the control interface to operate the air recirculation function, the image displayed in the switch will change to display your chosen position (external or internal circulation), if the air intake is closed the air inside the car is recirculated, preventing the entry of traffic fumes.

Recirculation mode is automatically activated when the screenwashers are used or reversing.









**Note:** *Leaving the system in recirculation mode can cause the windscreen to mist. If this happens, switch off recirculation and turn the controls to maximum demisting.*

## Air Distribution Mode

Select the corresponding Air Distribution Mode Touch Button as required to regulate the air distribution mode.

## AIR CONDITIONING AND AUDIO SYSTEMS

2

Touch Button	Icons on Interface	Air Distribution Mode
		To 'face'
		To 'face' and 'feet'
		To 'feet'
		To 'feet' + 'windscreen'

To 'face'. Directs air to the side, centre and centre console vents.

To 'face' and 'feet'. Directs air to the footwell, side, centre and centre console vents.

To 'feet'. Directs air to the footwell vents.

**Note:** In this mode, a small amount of airflow will be directed to the side, front side window and windscreen/defrost Vents.

To 'feet' + 'windscreen'. Directs air to the footwell, windscreen/defrost and front side window vents.

**Note:** In this mode, a small amount of airflow will be directed to the side vents.

### Blower Speed Control

Slide the blower speed segments left or right to regulate the blower speed, the lowest position is 1.

Touch the blower speed segment to quickly set the required blower speed.

### Temperature Control

Slide the temperature segment left or right to regulate the temperature of the air supplied by the vents.

Touch the temperature segment to quickly set the required temperature.

# AIR CONDITIONING AND AUDIO SYSTEMS

## Control Panel

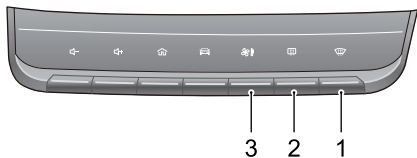

- 1 Defrost/Demist Button
- 2 Heated Rear Window Button
- 3 A/C Control Shortcut

## Defrost/Demist



Press Defrost/Demist Button on the control panel or the touch button on the display, the indicators on the button and display illuminate, the AC cooling and external circulation functions are switched on, and the system enters the most effective warm or cold air setting to clear the windshield and side window.

Pressing the Defrost/Demist Button or the touch button on the display again will exit the defrost/demist state, the indicator goes out, and the system will return to the previous state.

In the defrost/demist mode, operation of the AC cooling on/off button will switch the compressor on or off; operation of the air circulation mode button will switch between internal circulation and external circulation, without affecting the defrost/demist mode in either case; operation of other air distribution modes will switch to a corresponding air distribution mode and quit the defrost/demist mode.

**Note:** *When the defrost/demist function is switched on below a preset temperature, the heated rear window function will automatically operate, the Defrost/Demist button and the heated rear window button indicator lights will illuminate simultaneously.*

## Heated Rear Window



The heating elements on the inside of the rear window are easily damaged. **DO NOT** scrape or scratch the inside of the glass. **DO NOT** stick labels over the heating elements.



Press this button on the control panel to operate the heated rear window function, the indicator in the switch will illuminate. The heated rear window function will automatically turn off after operating for 15 minutes. If the switch is pressed again within 5 minutes, the heated rear window will operate and then remain on for a further 8 minutes. Pressing the switch whilst the heated rear window is on will switch off the function and extinguish the indicator in the switch.

**Note:** The heated rear window will only operate when the engine is running.

**Note:** Heated door mirrors only operate when the heated rear window is activated.

## A/C Display



- 1 Temperature Status
- 2 AC Cooling Status
- 3 Blower Speed/Air Distribution Mode Status :
  - For 'face'
  - For 'face' and 'feet'
  - For 'feet'
  - For 'feet' and 'windscreen'
  - For 'windscreen'
- 4 Air Recirculation Mode Status :
  - Internal circulation
  - External circulation

# AIR CONDITIONING AND AUDIO SYSTEMS

## Automatic Temperature Control \*

### Infotainment Screen Control Interface

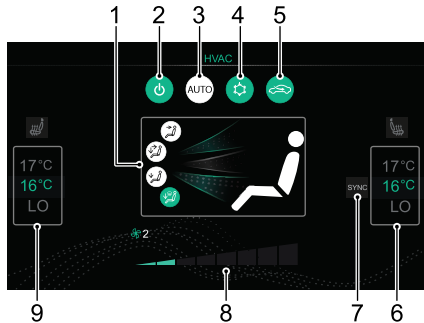

- 1 Air Distribution Mode
- 2 System On/Off
- 3 Auto Mode
- 4 AC Cooling On/Off
- 5 Air Circulation Mode
- 6 Right Zone Temperature Control
- 7 Temperature Zone Control
- 8 Blower Speed Control
- 9 Left Zone Temperature Control

## System On/Off

Touch the System On/Off Button on the control interface to switch the system on, all functions will revert to the state before shutdown. Touch again to switch off.

**Note:** *Turning off the infotainment screen will not affect the operation of the AC system*

## AC Cooling On/Off

Touch the AC Cooling On/Off Touch Button to turn the AC cooling function ON/OFF.

### Note:

- 1** *The cooling/heating mode of the air conditioning will only operate when the engine is running.*
- 2** *The heating function is still available, when the AC cooling is switched off.*
- 3** *A small amount of water may remain in the air conditioner after usage, this may produce a peculiar smell. If this is a particular issue, it is recommended to switch off the cooling function*

*and run the blower for a while with the engine running prior to switching off.*

## Air Circulation Mode

Touch the recirculation button on the control interface to operate the air recirculation function, the image displayed in the switch will change to display your chosen position (external or internal circulation), if the air intake is closed the air inside the car is recirculated, preventing the entry of traffic fumes.

Recirculation mode is automatically activated when the screenwashers are used or reversing.

**Note:** *Leaving the system in recirculation mode can cause the windscreen to mist. If this happens, switch off recirculation and turn the controls to maximum demisting.*

## Auto Mode

Adjust the temperature on the infotainment screen control interface, set the target temperature required and then

# AIR CONDITIONING AND AUDIO SYSTEMS

press the AUTO On/Off button to enable the auto control function.

In the auto mode, the air distribution mode and the blower speed are automatically adjusted to reach and maintain the required temperature.









**Note:** To ensure the auto control operates efficiently, all windows and the sunroof must be closed and the A/C inlet grille must be clear of obstruction. In addition, the solar sensor on the upper part of the instrument panel should not be covered.

## Manual Mode

The air distribution mode and blower speed can be adjusted manually according to personal preference. In this case the AUTO indicator will extinguish.

## Air Distribution Mode

Select the corresponding Air Distribution Mode Touch Button as required to regulate the air distribution mode.

Touch Button	Icons on Interface	Air Distribution Mode
		To 'face'
		To 'face' and 'feet'
		To 'feet'
		To 'feet' + 'windscreen'

To 'face'. Directs air to the side, centre and centre console vents.

To 'face' and 'feet'. Directs air to the footwell, side, centre and centre console vents.

To 'feet'. Directs air to the footwell vents.

**Note:** In this mode, a small amount of airflow will be directed to the side, front side window and windscreen/defrost Vents.



# AIR CONDITIONING AND AUDIO SYSTEMS

To 'feet' + 'windscreen'. Directs air to the footwell, windscreen/defrost and front side window vents.

**Note:** *In this mode, a small amount of airflow will be directed to the side vents.*

## Temperature Zone control

Touch the temperature zone control button to switch the system between single or dual temperature zone control. When the button is illuminated both zones are synchronised.

## Blower Speed Control

Slide the blower speed segments left or right to regulate the blower speed, the lowest position is 1.

Touch the blower speed segment to quickly set the required blower speed.

## Temperature Control

Slide the temperature up or down to regulate the temperature of the air supplied by the vents.

## Control Panel

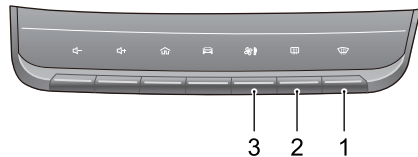

- 1 Defrost/Demist Button
- 2 Heated Rear Window Button
- 3 A/C Control Shortcut

## Defrost/Demist



Press Defrost/Demist Button on the control panel or the touch button on the display, the indicators on the button and display illuminate, the AC cooling and external circulation functions are switched on, and the system enters the most effective warm or cold air setting to clear the windshield and side window.

# AIR CONDITIONING AND AUDIO SYSTEMS

---

Pressing the Defrost/Demist Button or the touch button on the display again will exit the defrost/demist state, the indicator goes out, and the system will return to the previous state.

In the defrost/demist mode, operation of the AC cooling on/off button will switch the compressor on or off; operation of the air circulation mode button will switch between internal circulation and external circulation, without affecting the defrost/demist mode in either case; operation of other air distribution modes will switch to a corresponding air distribution mode and quit the defrost/demist mode.

**Note:** *When the defrost/demist function is switched on below a preset temperature, the heated rear window function will automatically operate, the Defrost/Demist button and the heated rear window button indicator lights will illuminate simultaneously. Turn on or off this function, please operate in 'Vehicle Settings - HVAC'.*

## Heated Rear Window



**The heating elements on the inside of the rear window are easily damaged. DO NOT scrape or scratch the inside of the glass. DO NOT stick labels over the heating elements.**



Press this button on the control panel to operate the heated rear window function, the indicator in the switch will illuminate. The heated rear window function will automatically turn off after operating for 15 minutes. If the switch is pressed again within 5 minutes, the heated rear window will operate and then remain on for a further 8 minutes. Pressing the switch whilst the heated rear window is on will switch off the function and extinguish the indicator in the switch.

**Note:** *The heated rear window will only operate when the engine is running.*







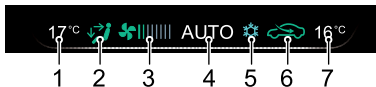

**Note:** *Heated door mirrors only operate when the heated rear window is activated.*

## A/C Status

## 7 Right Zone Temperature Status



2

- 1 Left Zone Temperature Status
- 2 Air Distribution Mode Status :
  -  For 'face'
  -  For 'face' and 'feet'
  -  For 'feet'
  -  For 'feet' and 'windscreen'
  -  For 'windscreen'
  -  Auto mode
- 3 Blower Speed Status
- 4 Auto Mode Status
- 5 AC Cooling Status
- 6 Air Recirculation Mode Status :
  -  Internal circulation
  -  External circulation

# AIR CONDITIONING AND AUDIO SYSTEMS

---

## Infotainment System

### Important Safety Information

- Do not attempt to fit, repair or modify the entertainment system by yourself, because there are high-voltage components in the device, which may cause electric shock. For internal inspection, adjustment or repair, please consult a local MG Authorised Repairer.
- Do not allow this entertainment and navigation system to come into contact with liquids. If liquids or foreign objects enter into this entertainment and navigation system, please park your vehicle at a safe place, immediately switch off the ignition and contact a local MG Authorised Repairer. Do not use the entertainment and navigation system in this condition because doing so may result in a fire, electric shock, or other failure.
- If you notice smoke, abnormal noises or odours from the entertainment system, or any other abnormal signs on the screen, switch the ignition off immediately and contact a local MG Authorised Repairer for service.

Using this entertainment system in this condition may result in permanent damage to the system.

- Operation of the navigation or video functions of the system is prohibited whilst the vehicle is in motion. MG Motor UK accepts no responsibility for any consequences caused by this operation. Please park your vehicle in a safe location select Park/Neutral, and apply the parking brake before making the necessary adjustments or watching "Video".
- Particularly high or particularly low temperatures will interfere with normal operation. If the vehicle is not used and parked in direct sun or in a cold location for a long time, the car may become particularly hot or cold, in this environment the system may not work properly. Once the temperature inside the car is back to normal, the system will resume normal function. If it does not resume, please contact an MG Authorised Repairer for assistance.
- Switch off entertainment and navigation system during refuelling.

- Excessive use of the entertainment and navigation system without the vehicle being driven or engine running can drain the vehicle low voltage battery.
- If the battery is disconnected or discharged, the data stored in the memory of this entertainment and navigation system will be erased.
- When using a mobile phone, keep the antenna of the mobile phone away from the screen to prevent the disruption of video signal in the form of spots, colored stripes, etc. on the screen.
- To protect the screen against damage, be sure to touch the panel buttons with your finger (a touch pen can be used for special calibration).
- The navigation system is designed only as a guide and does not relieve the driver of the responsibility for driving in accordance with traffic regulations.
- Please take care to protect the screen against direct sunlight. Extended exposure to direct sunlight will result in screen malfunction due to high temperature.
- When the temperature is beyond the operating temperature range (-30°C to +85°C), please do not use the screen, because the screen may not operate normally and could be damaged.
- Do not use excessive force to drag and drop or press the screen, damage or scratching may occur.
- To remove dust from the screen or clean the screen, power off the system first, then wipe the screen with a dry soft cloth. When wiping the screen, take care not to scratch the surface. Do not use irritative or abrasive chemical cleaners.
- Make sure that the warm or cool air flow from the air conditioner is not distributed directly onto the screen, damage to the entertainment device may occur due to excessive heat or moisture.
- When the backlight reaches the end of its service life, the screen will become dimmer and the image will no longer be visible, please contact a local MG Authorised Repairer.

### **Cautions for Using Screen**

- To protect the screen against damage, always touch panel keys with your finger. A touch pen may be used for special calibration.

# AIR CONDITIONING AND AUDIO SYSTEMS

---

## Additional Notes

- Some types of external storage devices may not be recognised. This may result in the files not being played or displayed normally.
- Because of file characteristics, file format, recorded application, playback environment, storage conditions and other factors, it may not be possible to play the files normally.

## Basic Operations

### Control Panel

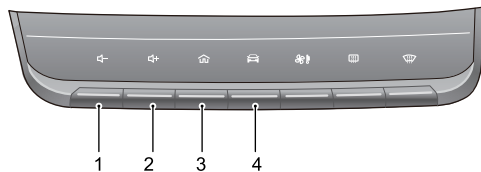

- 1 Volume Down Button  
Press to lower the volume.
- 2 Volume Up Button  
Press to increase the volume.
- 3  (HOME) Button  
Short press to return to the main interface.
- 4 Vehicle Setting Button  
Short press to enter the vehicle settings interface.

# AIR CONDITIONING AND AUDIO SYSTEMS

## Main System Interface



### 1 Radio/Music

Touch to enter the Radio/Music interface.

### 2 Navigation \*

Touch to enter the Navigation interface.

### 3 HVAC

Touch to enter the heating, ventilation and AC interface.

### 4 Others

Touch or swipe left or right at the bottom of the screen to view the following functions.

- Phone

Touch to enter the Bluetooth Phone interface.

- Car

Touch to enter the Vehicle Settings interface.

- Set up

Touch to enter the Settings interface.

- Apple Carplay \*

Touch to enter the Apple Carplay interface.

- Android Auto \*

Touch to enter the Android Auto interface.

- Pictures

Touch to enter the Pictures interface.

- Video

# AIR CONDITIONING AND AUDIO SYSTEMS

---

Touch  to enter the Video interface.

- Display Off

Touch  to turn off the display; touch again to wake up the display.

## **Power On/Off**

### **Power On**

If the vehicle power is turned off with the system currently in playback mode, the system will be automatically powered on when the vehicle power is turned on again.

If the vehicle power is turned off with the system in the Off state, short press the Power button on the system control panel to power-on the system after the vehicle power is turned on again.

With the system on, long press the HOME button on the system control panel to enter the Standby mode; keep pressing the button and the system will reboot automatically.

### **Power Off**

Pressing the Start/Stop button to the Off position will automatically switch off the Infotainment system.



# AIR CONDITIONING AND AUDIO SYSTEMS

## Standby Mode

With the Start/Stop switch on, long press the HOME button to allow the Infotainment system to enter the Standby mode, the operation of the Infotainment system may be suspended.

In Standby mode, all sounds will be muted. To cancel the Standby mode, short press the HOME button.

The following operations can also cancel the Standby mode:

- The system automatically switches to the parking image during parking.
- Turn off the Start/Stop switch, the system shuts down directly.

## Control Buttons on Steering Wheel

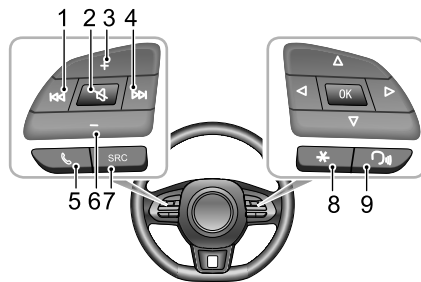

### 1 ⏮ Button

When playing audio, short press to return to the beginning of the track (except the Bluetooth music mode), short press again to switch to previous track, and long press to rewind (except the Bluetooth music mode). When playing video, short press to switch to previous video, and long press to rewind. When playing radio, short press to automatically search for

# AIR CONDITIONING AND AUDIO SYSTEMS

---

the previous station; long press to manually search for the previous station.

2  Button

Mute/Unmute.

3 Volume Up Button

4  Button

When playing an audio/video, short press to switch to next track/video (except the Bluetooth music mode), and long press to fast forward. When playing radio, short press to automatically search for the next station; long press to manually search for the next station.

5  Button

Short press to hang up if in calling/talking state; short press to answer and long press to reject if in incoming call state.

6 Volume Down Button

7 SRC Audio Source Switch Button

Switch to the next available media audio source.

8 “\*” Button on Steering Wheel

“\*” button on the steering wheel can be set as the shortcut key of SmartPhone / Home / Car.

9 Speech Recognition Function Button

Activate/Cancel speech recognition function. This button will only be used after Vehicle-Mobile Phone Interconnection \* is enabled.

## Volume Adjustment

The audio volume can be adjusted by the control panel and the buttons on the steering wheel. During the volume adjustment, the system automatically pops up a volume indication window which changes smoothly with the adjustment process.

**Note:** *The volume buttons on the steering wheel and control panel can only be used for the volume adjustment of audios of media and communication type.*

**Note:** *The playback volume of Bluetooth music can be adjusted by the device itself and the Infotainment player.*

## Connecting/Disconnecting a USB Storage Device

### Inserting a USB Storage Device

Connect a USB device to the USB port for connection.

### Removing a USB Storage Device

Check and confirm that there is no data being accessed, then pull out the USB storage device.

**Note:** *If data loss or damage to the storage device occurs for any reason, the data will generally never be recovered. For damages, costs or expenses due to data loss or damage, the manufacturer assumes no responsibility.*

**Note:** *Some USB storage devices may be unidentifiable.*

**Note:** *The Infotainment system may not achieve its optimum performance when using with some USB storage devices.*

# AIR CONDITIONING AND AUDIO SYSTEMS

---

*Note: Using USB hub or extension cable may not identify USB device.*

## **Bluetooth Phone**

### **Instructions**



- Connection to all mobile phones featuring Bluetooth wireless technology is not guaranteed.
- The mobile phone used must be compatible with the Infotainment system so that all functions of Bluetooth phone of the system can function correctly
- When using Bluetooth wireless technology, the Infotainment system may not operate all functions on the mobile phone.
- When transmitting voice and data via Bluetooth technology, the straight-line distance between the Infotainment system and the mobile phone should not exceed 10 metres. However, the actual transmission distance may be shorter than the estimated distance, depending on the usage environment.
- If Private mode is selected on the mobile phone, hands-free call function will be disabled.
- When the Infotainment system is turned off, the Bluetooth connection will be disconnected.

# AIR CONDITIONING AND AUDIO SYSTEMS

2

- Due to Bluetooth wireless connection, interruption or error occurring in the process of transmission in some extreme cases, and the Infotainment system may be unable to be paired and connected with the mobile phone. At this time, it is recommended to clear the paired devices in the device list on the mobile phone and the Infotainment system, and conduct pairing again.

## Bluetooth Pairing and Connection



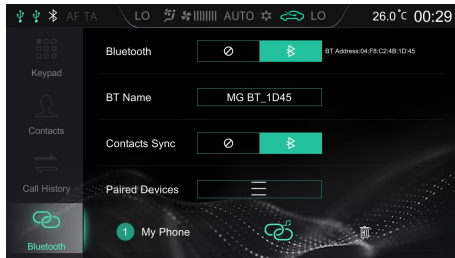

If Bluetooth is not enabled, no Bluetooth icon is displayed in the status bar; if Bluetooth is enabled but no device is connected,  is displayed in the status bar; if Bluetooth is enabled and any device is connected,  is displayed in the status bar.

The steps of Bluetooth pairing and connection are as follows:

- Touch [Bluetooth] in the Settings interface to enter the Bluetooth connection settings interface, and touch  to enable the Bluetooth function.



# AIR CONDITIONING AND AUDIO SYSTEMS

- The system displays the Bluetooth address and the device name.
- Enable the Bluetooth on the mobile phone and search for the Infotainment system for pairing. The mobile phone will receive a Bluetooth Pairing request, after the pairing is completed, a prompt message of Connection Completed will appear. If the pairing fails, please repeat the above steps.
- The mobile phones that have been successfully paired will be stored in the list of paired devices. Touch  to view the Device List. Touch  to connect to the mobile phone Bluetooth, and touch  to disconnect the Bluetooth. Touch  to remove the mobile phone from the list of paired devices.

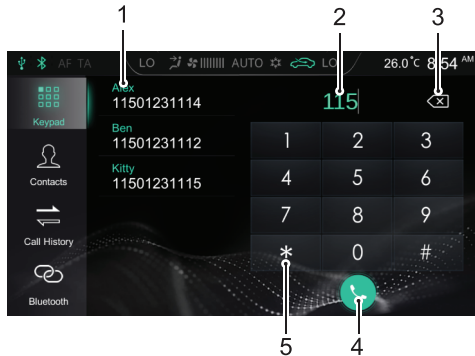

## Keypad

Touch [Keypad] in the Bluetooth Phone interface to enter the Dial Pad interface.



- 1 Address List/ Paired Contacts
- 2 Input Box
- 3 Back/Delete Button
- 4 Make a Call

# AIR CONDITIONING AND AUDIO SYSTEMS

Touch  to make a call; when the Bluetooth phone is connected, touch  to end the call.

## 5 Input Keypad Area

Input figures and symbols.

## Contacts

Touch [Contacts] in the Bluetooth Phone interface to enter the Contacts interface.

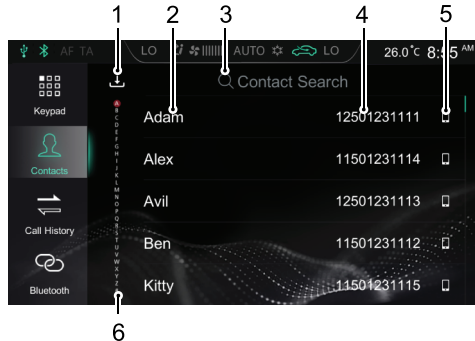

## 1 Download Contacts

When connected to a mobile phone via Bluetooth the entertainment system default setting will automatically download your contacts. The Auto

# AIR CONDITIONING AND AUDIO SYSTEMS

---

Contacts Download function can be disabled or enabled in the Connections Setting Interface.

Click  in the Contacts interface to download the Contacts manually.

## 2 Contact Name

## 3 Search for a Contact

Touch [Contact Search] in the interface, input the initial letter of the name to be searched, after the search is completed, touch the contact to make a call.

## 4 Phone Number

## 5 Phone Type

When a contact has multiple phone numbers, touch



to switch the phone number type and select the phone number to make a call.

## 6 Quick Contact Search

Touch the letter on the left of the interface or swipe the screen to quickly locate the contact with this letter as the initial letter.

**Note:** For some mobile phones, a dialog box asking whether to download Bluetooth phone contacts will pop up before downloading the Bluetooth phone contacts.

**Note:** Since the system temporarily does not support some commercially available mobile phones, the case of no synchronisation of Bluetooth phone book will occur on non supported phones.

**Note:** New contacts that are added will not be displayed until the next synchronisation is carried out.



# AIR CONDITIONING AND AUDIO SYSTEMS

2

## Call History

Touch [Call History] in the Bluetooth Phone interface to enter the Call History interface.

Touch the required call history record in the list to call the contact.

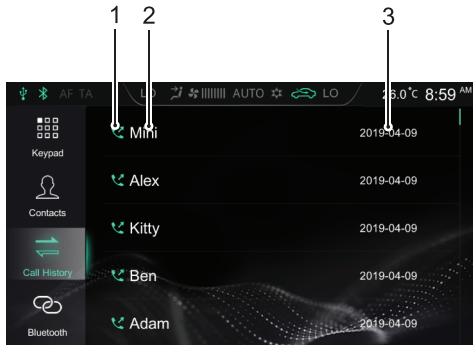

### 1 Call History Type

Dialed Calls:

Received Calls:

Missed Calls:

2 Contact Name/Phone Number

3 Talk Time

Call History is arranged by time and date in reverse chronological order.

## Bluetooth Connection

Touch [Bluetooth] to enter the Bluetooth Connection interface. Refer to "Bluetooth Pairing and Connection" in this section for details.

# AIR CONDITIONING AND AUDIO SYSTEMS

---



## Making a Call

You may make a call using the following methods:

- Keypad Input: Refer to “Keypad” in this section for details.
- Call the number in Contacts: Refer to “Contacts” in this section for details.
- Call the number in Call History: Refer to “Call History” in this section for details.
- Make a call directly on the mobile phone.

## End a Call



You may end a call using the following methods:

- Touch  to hang up.
- Short press  on the steering wheel to hang up.
- Hang up on the mobile phone.



**Note: It is illegal to operate a mobile telephone whilst driving. If you wish to make, or take a call using your mobile phone directly, please ensure you pull over in a suitable location and operate the mobile phone where it is safe and legal to do so.**

## Incoming Call

### Answer an Incoming Call

- Touch  to answer an incoming call.
- Short press  button on the steering wheel to answer an incoming call.
- Answer an incoming call on the mobile phone.

### Reject an Incoming Call

- Touch  to reject an incoming call.
- Long press  button on the steering wheel to reject an incoming call.
- Reject an incoming call on the mobile phone.

**Note: It is illegal to operate a mobile telephone whilst driving. If you wish to make, or take a call using your mobile phone directly, please ensure you pull over in a suitable location and operate the mobile phone where it is safe and legal to do so.**

# AIR CONDITIONING AND AUDIO SYSTEMS

## Switch to Private Mode

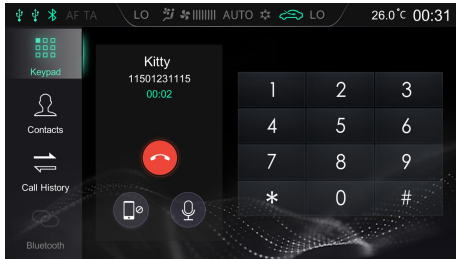

During a call, touch  to enter the Private Mode (Speaker Mode by default).

During a call, touch  to restore the Speaker Mode.

During a call, touch  to switch between Microphone Mute or Enabled function.

In Private Mode, you may continue with the call using the mobile phone; the speakers and microphone of the

Infotainment system will be muted. But Bluetooth is still connected.

**Note:** *It is illegal to operate a mobile telephone whilst driving. If you wish to make, or take a call using your mobile phone directly, please ensure you pull over in a suitable location and operate the mobile phone where it is safe and legal to do so.*

# AIR CONDITIONING AND AUDIO SYSTEMS

## Entertainment

### Precautions for Playing a Storage Medium Mode

- The system supports USB drives and Bluetooth storage media.
- If the USB device media is not in use, DO NOT leave the device connected. This may result in connection deterioration.
- Do not remove USB device whilst media is playing. Failure to follow these instructions could result in corrupted data.
- Keep the USB port dry and free from debris. The port will become unusable if it is blocked.

### Radio

Touch the Radio/Music area in the main interface, and touch [Radio] again to enter the Radio interface.

To listen to the broadcasting of different bands, touch [DAB] \*, [FM] or [AM] in the playback interface to switch between DAB and radio bands. Pressing the SRC button can also switch between the different radio bands.

### DAB \*

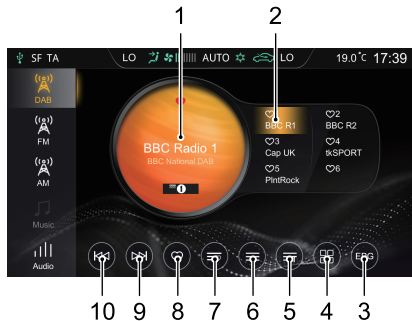

- 1 Current Station Name or Frequency  
Touch [DAB] \*, [FM] or [AM] to switch the band.
- 2 Display of Favorite Stations
- 3 Electronic Program Guide
- 4 DAB Categories List
- 5 Radio information  
Touching the button will display radio information, such as text, picture.

# AIR CONDITIONING AND AUDIO SYSTEMS

## 6 Station List

## 7 List of Favorite Stations

## 8 Add a Station to/Remove a Station from Favorites

## 9 Next Station

Short press to automatically search for the next station; long press to manually search for the next station.

## 10 Previous Station

Short press to automatically search for the previous station; long press to manually search for the previous station.

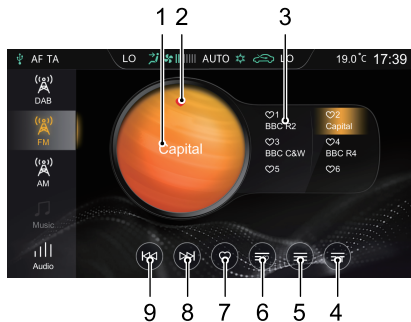

## FM/AM



### 1 Current Station Name or Frequency

Touch [DAB] \*, [FM] or [AM] to switch the band.

### 2 Station Favorites State

 indicates that the station has been added to Favorites;  indicates that the station is not added to Favorites.

### 3 Display of Favorite Stations

# AIR CONDITIONING AND AUDIO SYSTEMS

## 4 Radio Information

Touching the button will display radio information, such as text, picture.

## 5 Station List

## 6 List of Favorite Stations

## 7 Add a Station to/Remove a Station from Favorites

## 8 Next Station

Short press to automatically search for the next station; long press to manually search for the next station.

## 9 Previous Station

Short press to automatically search for the previous station; long press to manually search for the previous station.

Touch [Audio] in this interface, and the system skips to the Audio Settings interface.

## USB Music

Insert a USB storage device into the USB port, and the system automatically loads the music from the storage device.

Touch the Radio/Music area in the main interface, and touch [USB Music] again to enter the USB Music Playback interface.



# AIR CONDITIONING AND AUDIO SYSTEMS

---

## 1 USB Drive

When there are two USB drives, you may choose to play music in USB1 or USB2.

## 2 Album Cover

## 3 Play/Pause

## 4 Track Playback Progress Bar

Track playback progress is displayed by the coil, drag the progress bar to skip to certain playing point.

## 5 Song/Artist/Album Name

## 6 USB Music List

Touch to enter the corresponding Folder List interface, then touch to select and play the track you prefer.

## 7 Random Playback Mode

You may switch between Random Playback and Folder Random Playback.

## 8 Loop Playback Mode

You may switch between Single Loop, Folder Loop and Loop All.

## 9 Next Track

Short press to switch to the next track; long press to fast forward.

## 10 Previous Track

Short press to switch to the previous track; short press during playing to return to the beginning of the track; long press to fast rewind.

## 11 Current Elapsed Time

Touch [Audio] in this interface, and the system skips to the Audio Settings interface.

# AIR CONDITIONING AND AUDIO SYSTEMS

## Bluetooth Music

Please connect a Bluetooth device first before playing Bluetooth music. Refer to "Bluetooth Pairing and Connection" in "Bluetooth Phone" section for details.

After the Bluetooth device is connected with the system, touch the Radio/Music area in the main interface, and then touch [BT Music] to enter the Bluetooth Music playback interface.

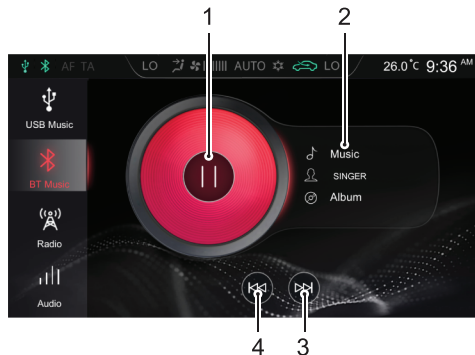

- 1 Play/Pause
- 2 Song/Artist/Album Name
- 3 Next Track
- 4 Previous Track

Touch [Audio] in this interface, and the system skips to the Audio Settings interface.



## USB Video

Insert a USB storage device into the USB port, and the system automatically loads the videos from the storage device.

**Note:** Due to differences in the compression ratio and bit rate of the multimedia formats downloaded from the Internet and other factors, the actual situation of the decoding result shall prevail.

**Note:** For your driving safety, when the vehicle speed reaches a certain value, the video safety mode will be activated automatically, the video cannot be played at that moment.

**Note:** The video cannot be played during a call.

Touch [Video] in the main interface to enter the Video Playback interface.

**Note:** When playing a video, click the screen to wake up the menu bar mode, and click it again to exit the menu bar mode.

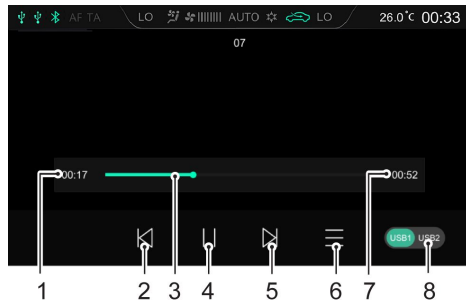

1 Current Elapsed Time

2 Previous Video

Short press to switch to the previous video; long press to fast rewind.

3 Playback Progress Bar

Drag the progress bar to skip to certain playing point.

4 Play/Pause

5 Next Video

# AIR CONDITIONING AND AUDIO SYSTEMS

---

Short press to switch to the next video; long press to fast forward.

## 6 Video List

You may view and play the corresponding video file.

## 7 Total Video Duration

## 8 USB Drive

When there are two USB drives, you may choose to play videos in USB1 or USB2.

## Pictures

Insert a USB storage device into the USB port, and the system automatically loads the pictures in the storage device.

Touch [Pictures] in the main interface to enter the picture Playback interface.

Touch a picture file to display it in full screen.

**Note: Whilst viewing a picture file, click the screen to wake up the menu bar mode, and click it again to exit the menu bar mode.**

# AIR CONDITIONING AND AUDIO SYSTEMS

## Picture Browsing Interface



- 1 Slide Show
- 2 Zoom In
- 3 Zoom Out
- 4 Thumbnail
- 5 Pictures List

You may view and play the corresponding picture file.

- 6 USB Drive

When there are two USB drives, you may choose to view pictures in USB1 or USB2.

**Note:** The system supports the viewing of pictures stored on a USB device. Due to differences in picture resolution, format compression ratio and some other factors not all pictures may be decoded and displayed.

**Note:** Swipe to the left or right on the screen to switch to the next or previous picture.

# AIR CONDITIONING AND AUDIO SYSTEMS

---

## **Vehicle-Mobile Phone Interconnection \***

Only applicable to models that feature Vehicle-Mobile Phone Interconnection.

## **Apple CarPlay \***

Apple CarPlay enables information interaction between the mobile phone and the on-board Infotainment system, including map, music, telephone, short message, podcast, voice recognition .

### **Connection Method**

- 1 Confirm that your mobile phone has the Carplay function and that it is turned on.
- 2 Connect the mobile phone to the Infotainment system mainframe using the USB cable.
- 3 In the main interface, touch [Apple CarPlay] area to enter the Apple CarPlay interface.
- 4 After the vehicle and mobile phone are successfully connected, you can operate the iPhone using the Infotainment system screen.

- 5 Press the HOME button on the control panel to return to the main system interface.

## **Android Auto \***

Android Auto enables information interaction between the android mobile phone and the on-board Infotainment system, including map, music, telephone, messages, voice commands.

For the first time, download and install Android Auto in the application market.

When using , connect the mobile phone to the Infotainment system mainframe using the USB cable. In the main interface, touch [Android Auto] area to enter the Android Auto interface. Operate according to the interface prompt, then you can use the function once the connection is successful.

## **A/C**

Touch the A/C area in the main interface to enter the A/C System Settings interface. Refer to “Electronic Temperature Control \*” and “Automatic Temperature Control \*” section in this Manual for details.

## **Vehicle Settings**

Press the Car button on the control panel or touch [Car] in the main interface to enter the Vehicle Settings interface.

### **Driving Assist \***

Touch [Driving Assist] in the Vehicle Settings interface to enter the Driving Assist Settings interface. You can set up the driving assistance system.

### **Comfort Convenience**

Touch [Comfort Convenience] in the Vehicle Settings interface to enter the Comfort Convenience Settings interface where the lights and other functions can be set.

### **Driving Maintenance**

Touch [Driving Maintenance] in the Vehicle Settings interface to enter the Driving Maintenance Settings interface. You can set up some driving control systems.

### **Factory Setting**

Touch [Factory Setting] in the Vehicle Settings interface to enter the Restore Factory Settings interface.

# AIR CONDITIONING AND AUDIO SYSTEMS

---

Touch [Reset] in the Factory Settings interface, and a Reset prompt appears. Please select as needed. Please use with caution.

## **Settings**

Touch [Setup] in the main interface to enter the Settings interface.

## **Audio Settings**

Touch [Audio] in the Settings interface to enter the Sound Settings interface. You can set the volume, EQ and sound stage.

## **RDS/DAB Settings**

Touch [RDS/DAB] in the Settings interface to enter the RDS/DAB Settings interface. You can set the RDS/DAB related functions.

## **Time & Date Settings**

Touch [Time] in the Settings interface to enter the Time & Date Settings interface to set the date and time.

## **Bluetooth Settings**

Touch [Bluetooth] in the Settings interface to enter the Bluetooth Settings interface to set the Bluetooth

connection function. Refer to “Bluetooth Pairing and Connection” in this section for details.

## **Display Settings**

Touch [Display] in the Settings interface to enter the Display Settings interface. You can set the brightness, backlight mode and units.

## **System Settings**

Touch [System] in the Settings interface to enter the System Settings interface.

- You can view the help file, software version, hardware version, machine coding and other information of the system.
- Touch [Start] to enter Restore Factory Settings interface, you can select to restore Audio Setting, Radio list and Others to default factory settings as required. After restoring factory settings, the mainframe is reset to its original settings and all data in the Infotainment system will be deleted. Please use with caution.

# ADDENDUM – AIR CONDITIONING AND AUDIO SYSTEMS

---

## Restricted Operation During Apple CarPlay and Android Auto Telephone Calls

Whilst the Infotainment System is connected to a mobile telephone via Apple CarPlay or Android Auto, certain telephone functions may restrict the display change function.

During a telephone call using Apple CarPlay or Android Auto the Infotainment System screen displays details of the call and caller/contact. This screen cannot be changed or exited during the call and therefore restricts access to other functions that are available via the Infotainment System screen.

### *Air Conditioning and Heater (HVAC) Function Restrictions*

During an Apple CarPlay or Android Auto telephone call it is not possible to access the HVAC adjustment function within the Infotainment System. This means that blower speed and temperature settings cannot be accessed or adjusted.

To switch the AC blower on or off during a telephone conversation whilst using Apple CarPlay or Android Auto please hold the AC Control Shortcut key in the Control Panel for 3 seconds, the blower will switch on or off depending on the current working state.

Note: When switching the blower back on, the speed settings will revert to the settings prior to switching off.

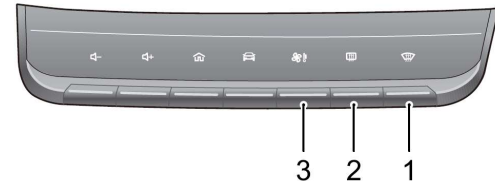

- 1 Defrost/Demist Button
- 2 Heated Rear Window Button
- 3 A/C Control Shortcut



## **Seats & Restraints**

---

*116 Seats*

*122 Seat Belts*

*133 Airbag Supplementary Restraint  
System*

*142 Child Restraints*

# SEATS & RESTRAINTS

---

## Seats

### Overview



*To avoid personal injuries due to the loss of control, DO NOT adjust the seats while the car is moving.*

An ideal position of the seat should make sure your driving position is comfortable, which allows you to hold the steering wheel with your arms and legs slightly bent and control all the equipment. Make sure your driving position is comfortable and enables you to maintain full control of the vehicle.

DO NOT recline the front seat backrest excessively. Optimum benefit is obtained from the seat belt with the backrest angle set to approximately 25° from the upright (vertical). The driver and front passenger seats should be positioned as far rearward as practical. Take care when adjusting the height of the front seat - the feet of the rear passenger could become trapped when the seat is lowered. A properly adjusted seat helps reduce the risk of injury from sitting too close to an inflating airbag.

## Head Restraint



*Adjust the height of the head restraint so that the top of it is in line with the top of the occupant's head. This location may reduce the risk of head and neck injuries in the event of a collision. DO NOT adjust or remove the head restraints while the car is moving.*



*DO NOT hang anything on any head restraint or head restraint rod.*

The head restraint is designed to prevent rearward movement of the head in the event of a collision or emergency braking, thereby reducing the risk of head and neck injuries.

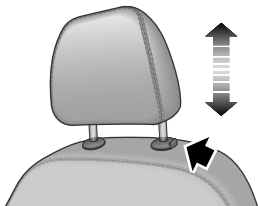

When adjusting a head restraint from low to high position, pull the head restraint directly upward, and gently press it downward after it reaches the desired position to make sure that it is locked in position. To remove the head restraint, press and hold the guide sleeve button (as indicated by the arrow) on the left of the head restraint, then pull the head restraint upward to remove it.

When adjusting a head restraint from high to low position, press the guide sleeve button (as indicated by the arrow) on the left of the head restraint, and press the head restraint downward; release the button after it reaches the desired position, and gently press the head restraint downward to make sure that it is locked in position.

### Front Seats

#### Manual Seat \*

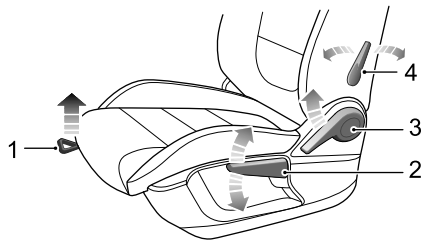

- Forward/Rearward Adjustment

Lift the lever (1) under the seat cushion, slide the seat into an appropriate position and release the lever. Make sure that the seat is locked in place.

## SEATS & RESTRAINTS

- **Cushion Height Adjustment \***

Lift the handle (2) repeatedly to raise the seat cushion; press the handle downward to lower the seat cushion.

- **Backrest Adjustment**

Lift the handle (3), adjust the backrest until it moves into a satisfiable position , put down the lever.

- **Lumbar Support Adjustment \***

Move the lever (4) to adjust the level of the lumbar support.

### Power Seat \*

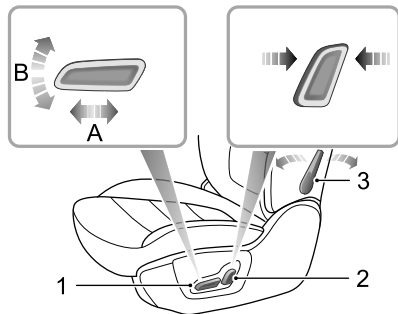

- **Forward/Rearward Adjustment**

Push the switch (1) forward or backward (A) to move the seat forward/backward.

- **Cushion Height Adjustment \***

Pull the switch (1) upward or push downward (B) to raise or lower the seat cushion.

- Backrest Adjustment

Move the switch (2) forward/backward to adjust the backrest until it reaches the desired angle.

- Lumbar Support Adjustment \*

Move the lever (3) to adjust the level of the lumbar support.

### Rear Seats

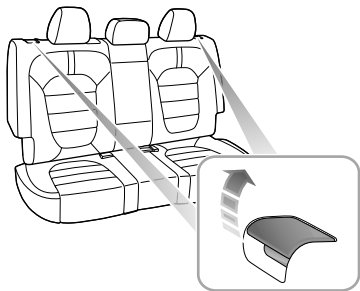

3

### Adjustment of Rear Seat Backrest

Pull the control lever located at the top of the rear seat backrest upwards to release the locked state of the backrest; then adjust the backrest to the desired position, release the lever. Ensure the backrest is completely locked in position.

## SEATS & RESTRAINTS

---

### Folding Rear Seats

To increase the luggage space, the rear seat backrest can be fully folded forward. When folding the backrest, completely insert the rear seat belt buckle into the corresponding slot first, then fully lower (or remove) all head restraints, pull the respective control lever at the top of the seat backrest upwards and fold the seat backrest forward.

To return the backrest to an upright position, pull the respective control lever at the top of the backrest to release the lock, raise the rear seat backrest, when the desired upright position is reached, a 'click' will be heard. Ensure the backrest is locked in position.

**Note:** *When returning the rear seat backrest to the desired position, make sure that the rear seat belt is not trapped.*

**Note:** *When the head restraint of the rear seat is not fully lowered or the backrest of the front seat is inclined backward excessively, the folding of the rear seat is very likely to damage the back of the front seat,*

*small storage compartment or head restraint of the rear seat.*

**Note:** *If the rear seat belt buckle is not completely inserted into the corresponding slot, folding the backrest is very likely to damage the rear seat backrest cover or foam.*

### Front Seat Heating \*



***If bare skin is in contact with the heated seats for excessive periods of time, it may cause burns.***

The seat cushion and backrest of front seats are provided with heating elements. After starting the car, access the air conditioning control interface and press the seat heating switch on the display to enable the heating function of the corresponding seat.



When pressing a seat heater switch, the corresponding seat will become warm. Press the switch again to stop the heating function. When the seat

heating function is activated, the operating indicator in the switch illuminates. When the seat cushion and backrest temperature reaches approximate 38°C, the heating function will be deactivated automatically.

### IMPORTANT

- DO NOT cover the heated seats with blankets, cushions or other insulation type objects or materials.
- If the seat temperature has reached 38°C and continues getting hotter when using seat heating system, please turn off the seat heating and contact an MG Authorised Repairer.
- Overuse of the driver's heated seat may cause drowsiness and could affect safety.

## SEATS & RESTRAINTS

---

### Seat Belts



*It is important that all seat belts are worn correctly. Always check that all passengers are wearing seat belts. DO NOT carry passengers that are unable to wear correctly positioned seat belts. Wearing seat belts incorrectly may cause serious injury or even death in the event of a collision.*



*Airbags can not replace seat belts. Airbags can only provide extra support when triggered, and not all traffic accidents will trigger airbags. Whether airbags are triggered or not, seat belts can reduce the risks of serious injury or death in accidents. Therefore, seat belts must be worn correctly.*



*NEVER unfasten a seat belt whilst driving. Serious injury or death may occur in the case of an accident or emergency braking.*



*NEVER fasten the driver seat belt or use a buckle replacement when the driver seat is vacant or when exiting the vehicle. This could cause the engine to restart automatically.*



This vehicle is equipped with a seat belt warning lamp to remind you to fasten your seat belt.

During driving, seat belts must be fastened, this is because:

- You can never predict if you will be involved in a collision accident and how serious it may be.
- In many cases of collision accidents, passengers with seat belts correctly fastened are well-protected, while passengers with seat belts not fastened suffer from serious injury or even death.

Therefore, all passengers must wear seat belts correctly, even during short-distance journeys.



### Protection Provided by Seat Belts



*It is of equal importance for passengers in the rear seat to fasten their seat belts correctly. Otherwise, passengers with seat belts not correctly fastened will be thrown forward in accidents, and will endanger themselves as well as the driver and other passengers.*

When the vehicle is in motion, the travelling speed of the occupants is identical to that of the vehicle.

In the event of a 'head on collision' or emergency braking, the vehicle may stop, but the occupants will carry on travelling until they come into contact with a stationary object.

This object may be the steering wheel, dashboard, windscreen and others. A correctly fastened seat belt will eliminate this risk of injury.

When the seat belt is worn correctly, it will lock automatically in collision accidents or emergency braking to reduce your speed together with the vehicle, so as to

prevent the out-of-control movement which may cause serious injury to driver and passengers.



## SEATS & RESTRAINTS

---

### Wearing Seat Belts



*Incorrectly worn seat belts could cause injury or death in the event of an accident.*



*Seat belts are designed for one person. DO NOT share seat belts.*



*DO NOT wrap a seat belt around when holding a baby or child in your arms.*



*Remove any heavy coats or clothing when wearing a seat belt, failure to do so can affect protection provided by the seat belt.*



*Seat belts should not be wrapped around hard or sharp objects such as pens, spectacles or keys to avoid additional injury to the users.*



*Seat belts cannot function correctly when the seats are reclined excessively. DO NOT drive when the seats are excessively reclined.*

The seat belts fitted to your vehicle are designed for use by normal sized adults. This part of the literature refers to adult use. For advice on seat belt use with children, please see 'Children and Seat Belts'.

All seat belts are 3 point lap-diagonal belts.

In order to maintain effective protection, the passengers must sit in the correct orientation, feet placed on the floor in front of them, with an upright body (no excessive recline) and the seat belt correctly fastened.

### Fastening Seat Belts

Please follow the instructions below to fasten the seat belts correctly.

- 1 Adjust the seat correctly.
- 2 Hold the metal tab, pull the seat belt out steadily over the shoulder and across your chest. Ensure there is no twist on the belt.

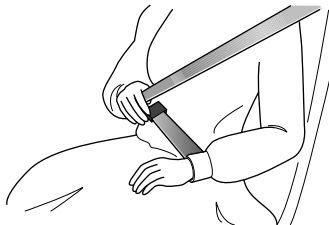

- 3 Insert the metal tab into the buckle until you hear a 'click', this indicates the seat belt is securely locked.

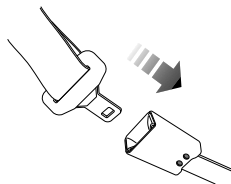

- 4 Remove any slackness in the belt by pulling up on the diagonal section of the belt.
- 5 To release the seat belt, press the red button on the buckle. The seat belt will retract automatically to its original place.

## SEATS & RESTRAINTS

### IMPORTANT

- Always ensure the seat belt will not become trapped in the door aperture when closing the door, damage will occur.
- Pulling the seat belt out too quickly may cause it to 'lock'. In this case, allow the seat belt to retract slightly and then pull it across your body slowly.
- If it is difficult to pull the seat belt out, it may be due to twisted webbing. If this is the case, fully extract the seat belt, remove the twist, allow the seat belt to retract slowly.
- When using the rear seat belts please ensure they are fully retracted into the correct position to avoid jamming in the rear seat catches. Even if the seat belt is not completely smoothed, it is still required to be worn during driving, but the twisted part of the seat belt shall not contact the passenger. When this happens, please go to an MG Authorised Repairer for repair.

### Correct Routing of the Seat Belts



**Ensure the seat belt is correctly positioned on the body, NEVER cross the neck or abdomen, NEVER pass the seat belt behind the back or under the arms.**

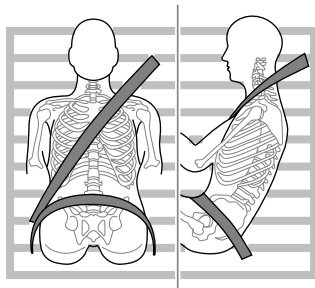

When wearing seat belts, the lap belt section should be positioned as low as possible across your hips. Never cross the abdomen. In the event of a collision, the lap belt can apply a force on the hips and reduce the possibility of you

slipping under the lap belt. If you slip under the lap belt, the belt will apply force on your abdomen, which may cause serious or fatal injuries. The diagonal section of the belt should cross the middle of the shoulder and the chest. In the event of emergency braking or collision, the diagonal section of the belt will be locked. Never position a seat belt across your neck, across the body under your arms or behind your back.

To ensure that the seat belts always provide maximum protection, ensure the belt is flat, not loose and contacts the body.

### Upper Anchorage Height Adjustment



***During driving, DO NOT adjust the height of seat belt.***



***Ensure the fixing point of seat belt is adjusted to the proper height and locked before driving, otherwise injury or even death may occur in collision accidents.***

The vehicle is equipped with a seat belt fixing point adjuster on driver seat and front passenger seat. Adjust the height so that the diagonal section of the belt crosses the middle of the shoulder. The seat belt should be positioned away from the neck and head and in a manner where the occupant cannot slide under the belt. Incorrect positioning will reduce the efficiency of the seat belt in the event of a collision or emergency braking.



Adjusting the seat belt fixing point correctly.

- I Hold the seat belt.

## SEATS & RESTRAINTS

---

- 2 Press release button and move the height adjuster to desired position. Move the adjuster by pushing the slider.
- 3 After moving the adjuster to desired position, release the button and try to move the adjuster downward to determine whether it is locked in place.

### Seat Belts During Pregnancy

Wearing correctly positioned seat belts will provide protection for both mother and unborn child in the event of a collision or emergency braking.



The diagonal section of the seat belt should pass across the chest as normal, the lap section of the belt should pass below the belly, low and snug on the hip bones. NEVER position the belt on or above the belly.

Please consult your physician for further details.

### Seat Belts and Disabilities

It is a legal requirement that all occupants wear seat belts, this include people with disabilities.

Depending upon the disability, consult your physician for further details.

### Children and Seat Belts

**!** *Proper protection measures must be taken for children during driving.*

For safety reasons, children shall ride in child restraint device fixed to the rear seat.

### Infants

**!** *Only recommended child restraints suitable for the age, height and weight of the child should be used.*

**!** *NEVER carry a child or infant with your arms during driving. When collision accidents occur, the weight of child will produce so great force that you can not hold the child. The child will be thrown forward and suffer serious injury or even death.*

The seat belts fitted to your vehicle are designed for adults, they are not suitable for children. In the event of an accident or collision the children are not secure, it could cause death or serious injury.

Infants **MUST** use a suitable child restraint device. Please consult the child seat manufacturers guide lines when selecting the correct seat. Follow the manufacturers instructions on installation. Please refer to "Child Restraints" in this chapter for more details.

### Older Children

**!** *NEVER share a seat belt amongst children. In the event of an accident or collision the children are not secure, it could cause death or serious injury.*

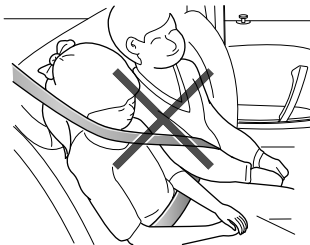

## SEATS & RESTRAINTS

---

As children grow and become older/larger it will get to the stage when they no longer require child seat restraints, at this point they will require use of the vehicle standard seat belt. Please ensure the seat belt is correctly positioned on the body of the child.

When fastening a seat belt for a child always check it for correct positioning. Adjust the height of seat belt to ensure the shoulder belt is kept away from the child's face and neck. Position the lap belt across the hips as low as possible, and tighten adequately. Correct positioning means that the seat belts can pass the applied force to the strongest part of child's body in accidents.

If the shoulder belt is too close to child's face or neck, it may be necessary to use a child booster cushion (always ensure that it meets any relevant laws or standards.

### Seat Belt Pre-tensioners



*The seat belt pre-tensioners will only be activated once and then **MUST BE REPLACED**. Failure to replace the pre-tensioners will reduce the efficiency of the vehicle's front restraint system.*



*If the pre-tensioners have been activated, the seat belts will still function as restraints, and must be worn in the event that the vehicle remains in a drivable condition. The seat belt pre-tensioners should be replaced at the earliest opportunity by an MG Authorised Repairer.*

The vehicle is fitted with seat belt pre-tensioners, these are designed to retract the seat belts and work in conjunction with the airbags in the event of a severe collision. They are designed to retract the seat belt and 'secure' the occupant in the seat.

The airbag warning light on the instrument pack will alert the driver to any malfunction of the seat belt



pretensioners.(see 'Warning Lamps and Indicators' in the 'Instruments and Controls' chapter).

The seat belt pre-tensioners can only be activated once, after activation they must be replaced. This may also involve replacement of other SRS components. Please refer to 'Replacing Airbag System Parts'.

### IMPORTANT

- Seat belt pre-tensioners will not be activated by minor impacts.
- The removal or replacement of a pre-tensioner must be carried out by the manufacturer trained, dealer technicians.
- 10 years from the initial date of registration (or installation date of a replacement seat belt pre-tensioner), some components will need to be replaced. The appropriate page of the Service Portfolio must be signed and stamped once the work has been completed.

## Seat Belt Checks, Maintenance and Replacement

### Seat Belt Checks



*Split, worn or frayed seat belts may not function correctly in the event of a collision, if there are any signs of damage, replace the belt immediately.*



*Always ensure the red release button on the seat belt buckle is pointing upwards to ensure easy release in the event of an emergency.*

Please follow the instructions below to check the seat belt warning lamp, seat belt, metal tab, buckle, retractor and fixing device regularly:

- Insert the seat belt metal tab into the corresponding buckle and pull seat belt webbing close to the buckle quickly to check that the belt clasp locks.
- Hold the metal tab and pull the seat belt forward quickly to check that the seat belt reel locks automatically, preventing the webbing from extending.

## SEATS & RESTRAINTS

---

- Fully extract the seat belt and visibly examine for twists, fraying, splits or worn areas.
- Fully extract the seat belt and allow to return slowly to ensure continual and complete smooth operation.
- Visibly examine the seat belt for missing or broken components.
- Ensure the seat belt warning system is fully functional.

If the seat belt fails any of the above tests or inspections contact an MG Authorised Repairer immediately for repairs.

### Seat Belt Maintenance



***DO NOT attempt to remove, install, modify, disassemble or dispose of the seat belts. Have any necessary repairs carried out by your MG Authorised Repairer. Inappropriate handling may lead to incorrect operation.***



***Ensure no foreign or sharp objects become lodged in the seat belt mechanisms. DO NOT allow liquids to contaminate the seat belt buckle, this could affect the buckle engagement.***

Seat belts should only be cleaned with warm soapy water. **DO NOT** use any solvent to clean the seat belt. **DO NOT** attempt to bleach or dye the seat belt, it may weaken the seat belt. After cleaning, wipe with a cloth and allow to dry. **DO NOT** allow the seat belt to fully retract before it is completely dry. Keep seat belts clean and dry.

If there are contaminants accumulated in the retractor, the retraction of the seat belt will be slow. Please use a clean and dry cloth to remove any contaminants.

### Replacing Seat Belts



***Collision accidents may damage the seat belt system. The seat belt system may not be able to protect users after damage which may result in serious injury or even death. After an accident, seat belts should be checked and replaced as needed immediately.***

Seat belts should not require change after minor collisions, however, some other parts of the seat belt system may require attention. Please consult an MG Authorised Repairer for advice.

### Airbag Supplementary Restraint System

#### Overview



*The airbag SRS provides **ADDITIONAL** protection in a severe frontal impact only. It does not replace the need, or requirement to wear a seat belt.*



*The airbags together with the seat belts provide optimum protection for adults, but it is not the case for infants. The seat belt and airbag systems in the vehicle are not designed for protecting infants. The protection required by infants should be provided by child restraints.*

The Airbag Supplementary Restraint System generally consists of:

- Front Airbags (fitted to the centre of the steering wheel and dashboard above the glove compartment)

- Seat Side Airbags (fitted to the outer side of the seat squab)
- Side Head Impact Protection Airbags (fitted behind the headlining)

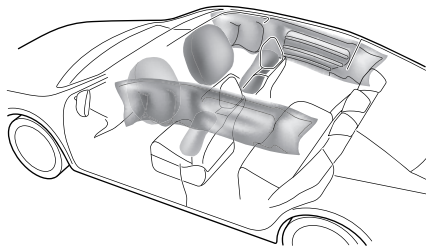

In the corresponding place where airbags are fitted, there is a warning sign stating 'AIRBAG'.

## SEATS & RESTRAINTS

---

### Airbag Warning Light



The airbag warning light is located in the instrument pack. If this lamp does not extinguish or illuminates during driving, it indicates that there is a failure in the SRS or seat belt. Please seek an MG Authorised Repairer at the earliest opportunity. An SRS or seat belt fault may mean the components may not be deployed in the event of an accident.

### Airbag Deployment



*Front seat passengers should not place feet, knees or any other part of the body in contact with, or in close proximity to a front airbag.*



*To minimise the risk of accidental injury from inflating airbags, seat belts should be worn correctly at all times. In addition, both driver and front seat passenger should adjust their seat to provide sufficient distance from the front airbags. If side airbags/side head impact protection airbags are fitted, both driver and front seat passenger should be seated to maintain sufficient distance from the upper part of the body to the sides of the vehicle, this will ensure maximum protection when the side airbags/side head impact protection airbags are deployed.*



**When airbags are deployed, children without proper protection may suffer from serious injury or even death. DO NOT carry children in the arms or on the knees during traveling. Children should wear seat belts suitable to age. DO NOT lean out of windows.**



**An inflating airbag can cause facial abrasions and other injuries if the occupant is too close to the airbag at the time of its deployment.**



**DO NOT affix or place any objects on, or adjacent to the airbags. This may affect the airbag passage or create projectiles that may cause injury or serious harm in the event of airbag deployment.**



**After deployment the airbag components become very hot. DO NOT touch any airbag related components, it may cause burns or serious injury.**



**DO NOT knock or strike the position where airbags or related parts are located, so as to avoid accidental airbag deployment which may cause serious injury or even death.**

In the event of a collision, the airbag control unit monitors the rate of deceleration or acceleration induced by the collision, to determine whether the airbags should be deployed. Airbag deployment is virtually instantaneous and occurs with considerable force, accompanied by a loud noise.

Provided the front seat occupants are correctly seated and with seat belts properly worn, the airbags will provide additional protection to the chest and facial areas in the event of the car receiving a severe frontal impact.

Side airbags and side head impact protection airbags are designed to offer additional protection to the side of the body facing the impact, if a severe side collision occurs.

## SEATS & RESTRAINTS

---

### IMPORTANT

- Airbags can not protect lower body parts of passengers.
- Airbags are not designed for rear collision, minor frontal or side impacts, or if the vehicle overturns; nor will it operate as a result of heavy braking.
- Deployment and retraction of the frontal and side airbags takes place very quickly and will not protect against the effects of secondary impacts that may occur.
- When an airbag inflates, a fine powder is released. This is not an indication of a malfunction, however, the powder may cause irritation to the skin and should be thoroughly flushed from the eyes and any cuts or abrasions of the skin.
- After inflation, front and side airbags deflate immediately. This provides a gradual cushioning effect for the occupant and also ensures that the driver's forward vision is not obscured.

### Front Airbags



***NEVER use a rearward facing child restraint on a seat protected by an ACTIVE AIRBAG in front of it, DEATH or SERIOUS INJURY to the CHILD can occur. Refer to 'Disabling the Passenger Airbag'.***



***Front seat passengers should not place feet, knees or any other part of the body in contact with, or in close proximity to a front airbag.***



***In extreme cases driving on very uneven surfaces may cause airbag deployment. Please take extra care when driving on uneven roads.***

Airbags are designed to deploy during serious impacts, the following conditions may cause airbag deployment.

- A frontal collision with unmovable or non deformable solid objects at a high speed.
- Conditions that can cause serious chassis damage, such as a collision with kerbstones, road edges, deep ravines or holes.

### Seat Side Airbags



*The manufacture and material of the seat is critical to the correct operation of side airbags. Therefore, please DO NOT fit seat covers which may affect side airbag deployment.*

In the event of a serious side impact, the relevant side airbag will deploy (only the affected side).

- The airbag will be deployed in the event that the side of the vehicle is impacted with a solid object or another vehicle.

### Side Head Impact Protection Airbags

In the event of a serious side impact, the relevant side curtain airbag will deploy (only the affected side).

- The side curtain airbag will be deployed in the event that the side of the vehicle is impacted with a solid object or another vehicle.

### Conditions in Which Airbags Will Not Deploy

The deployment of airbags does not depend on the vehicle speed, but on the object that the vehicle hits, angle of impact and the rate at which the car changes speed as a result of a collision. When the impact force of collision is absorbed or dispersed to vehicle body, airbags may not deploy; however, airbags may sometimes deploy according to impact condition. Therefore, the deployment of airbags shall not be judged based on the severity of vehicle damage.

### Front Airbags

Under certain conditions the front airbags may not be deployed. Some examples are listed below:

- The impact point is not central to the front of the vehicle.
- The impact is not of sufficient force (the impact is with an object that is not solid, such as a lamp post or central barriers).
- The impact area is high (collision with the tailgate of a truck).
- Impacts to the rear or side of the vehicle.

## SEATS & RESTRAINTS

- The vehicle rolling over.
- Frontal collision at an angle with guard bars.

### Seat Side Airbags and Side Head Impact Protection Airbags

Under certain conditions the seat side and side head airbags may not be deployed. Some examples are listed below:

- Side impacts at certain angles.
- Light side impacts such as a motorcycle.
- Impacts that are not central to the side of the vehicle, either too far toward the engine compartment or the loadspace.
- The vehicle rolling over.
- Frontal collision at an angle with guard bars.
- The angled impact is not of sufficient force (the impact is with an object that is not solid, such as a lamp post or central barriers).
- The impact is not of sufficient force (with another vehicle, stationary or moving).
- The impact is from the rear of the vehicle.

### Disabling the Passenger Airbag

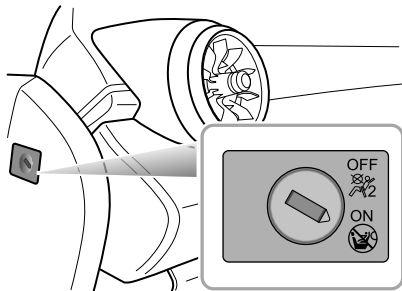

The passenger airbag switch is located at the left instrument panel end cover plate. Insert the key and turn the switch to on or off position to enable or disable the passenger airbag.

**Note:** *The Passenger Airbag should only be disabled when a rear facing child seat is fitted to the front passenger seat.*



## SEATS & RESTRAINTS

**Note:** When an adult is seated in the front passenger seat, ensure that the airbag is switched on.

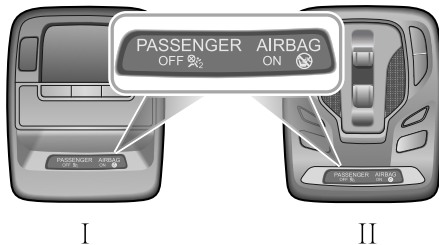

The passenger airbag status light is located in the roof mounted interior lamp assembly. The shape of the lamp assembly varies according to the configuration of the vehicle.

When the switch is turned to the OFF position, the OFF indicator light ( located in the PAB display panel in the lamp

assembly ) illuminates, this indicates that the passenger airbag is disabled.

When the switch is turned to the ON position, the ON indicator light ( located in the PAB display panel in the lamp assembly ) illuminates, this indicates that the passenger airbag is enabled.

# SEATS & RESTRAINTS

## Service and Replacement of Airbags

### Service Information



***DO NOT install or modify the airbag. Any changes to the vehicle structure or airbag system wiring harness are strictly prohibited.***



***Changes to vehicle structure is prohibited. This may affect the normal operation of the SRS.***



***DO NOT allow these areas to be flooded with liquid and DO NOT use petrol, detergent, furniture cream or polishes.***



***If water contaminates or enters the SRS it may cause damage and affect deployment. In this case contact an MG Authorised Repairer immediately.***

To prevent damage to the airbag SRS, the following areas should be cleaned sparingly with a damp cloth and upholstery cleaner ONLY:

- Steering wheel centre pad.
- Area of dashboard containing the passenger airbag.
- Area of roof lining and front pillar finishers which enclose the side head impact protection modules.

If the airbag warning lamp fails to illuminate, stays on, or if there is damage to the front or side of the vehicle, or the airbag covers show signs of damage, contact an MG Authorised Repairer immediately.

#### IMPORTANT

- The removal or replacement of an airbag module should be carried out by an MG Authorised Repairer.
- After 10 years from the initial date of registration (or installation date of a replacement airbag), some components will need to be replaced by an MG Authorised Repairer. The appropriate page of the Service Portfolio must be signed and stamped once the work has been completed.

### Replacing Airbag System Parts



***Even if the airbag does not deploy, collisions may cause damage to SRS in the vehicle. Airbags may not function properly after damage, and can not protect you and other passengers when a second collision occurs, which may cause serious injury or even death. To ensure that SRS can function properly after collision, please go to an MG Authorised Repairer to check airbags and repair as necessary.***

Airbags are designed for using once only. Once the airbag is deployed, you must replace SRS parts. Please go to an MG Authorised Repairer for replacement.

### Disposal of Airbags

When your vehicle is sold, ensure that the new owner knows the vehicle is equipped with airbags, and is aware of the replacement date of SRS.

If the vehicle is scrapped, the undeployed airbags may have potential risks, therefore, before the disposal, they must be

deployed safely in a certain environment by a professional from an MG Authorised Repairer.

# SEATS & RESTRAINTS

---

## Child Restraints

### Important Safety Instructions about Using Child Restraints

It is recommended that children below the age of 12 years old should be seated on the rear seat of the vehicle, in a child restraint system appropriate to the children's weight and size. Infants less than 2 years old should be restrained in an infant child restraint system.

It is recommended that a child restraint system that complies with UN ECE-R44 or ECE-R129 standard are fitted in this vehicle. Check markings on the child restraint system.

There are a number of child restraint systems available of different type and specification. For optimum protection, it is recommended that you choose restraint systems appropriate to the child's age and weight.

It is important to comply with installation instructions supplied by the child restraint manufacturer and that child restraint system is properly secured to the vehicle. Failure to follow these instructions may cause death or serious injury to the child in an event of a sudden stop or accident.

- All occupants, including children must wear seat belts or use an appropriate child restraint.
- It is recommended that children under 12 years of age or less than 1.5 metres tall should use the appropriate child restraint fitted to the rear seat.
- Only one child can be carried in any one restraint.
- Do not put the child on the lap or in arms when sitting in any seat.
- Always adjust the seat back rest to a proper position and ensure it is locked in position when installing a child seat or restraint.
- If installing a rear facing child restraint to the rear seat, the corresponding front seat should be adjusted forward; if installing a forward facing child restraint to the rear seat, you may need to adjust the height of the headrest to the lowest; if installing a forward facing child restraint to the front seat, you may need to remove its headrest.
- Never let your child stand or kneel on the seat during driving.
- Always ensure the child is seated correctly in the child restraint.

- The ways of using seat belts have a great influence on the maximum protection offered by the seat belt, you must comply with the child restraint manufacturer's instructions on proper use of seat belts. If seat belts are not properly fastened, a minor traffic accident may also lead to injury.
- Child restraints that are not fitted correctly may move and injure other occupants in the event of an accident or emergency braking. Therefore, even if there is no infant or child in the child restraint, it also should be fitted properly and securely in the vehicle.

### Warnings and Instructions on Use of Child Restraint on Front Passenger Seat



**NEVER** use a rearward facing child restraint on a seat protected by an **ACTIVE AIRBAG** in front of it, **DEATH** or **SERIOUS INJURY** to the **CHILD** can occur.



**In cases where there is a need to install a rear facing child restraint on the front passenger seat, use the key to deactivate the front passenger airbag function, or severe injury or even death can occur.**



**Once the child restraint is removed from the front passenger seat, use the key to reactivate the front passenger airbag.**



**When installing a child restraint on the front passenger seat, move the front passenger seat as far rearward as possible.**



**Use one child restraint per child.**

## SEATS & RESTRAINTS

---

Please study the safety warning label on the sun visor. Where possible always install child restraints on the rear seat. If it is necessary to install a child restraint on the front seat please observe the warnings above.

### Children's Safety and Side Airbags



***Children should not be allowed in areas where airbags may be deployed, there is a risk of serious injury.***



***Only recommended child restraints suitable for the age, height and weight of the child should be used.***



***DO NOT place any items in areas where airbags may be deployed, there is a risk of serious injury.***

In the event of a side collision, the side airbags can provide better protection for the passenger. However, when the airbag is triggered a very strong expansion force is generated, if the passenger's seating position is not correct,

the airbags or items in the side airbag deployment area may cause injury.

When the correct child restraint is used to secure the child properly in the rear seat and the child's seating position is correct, there is enough space between the child and the side airbag deployment region for the airbag to deploy without any hindrance, and thus provide the best protection.

### Child Restraints Groups

#### Secured Using 3 Point lap Diagonal Belts



**Please DO NOT put the rear facing child restraint in the front passenger seat, this may cause serious injury or even death.**

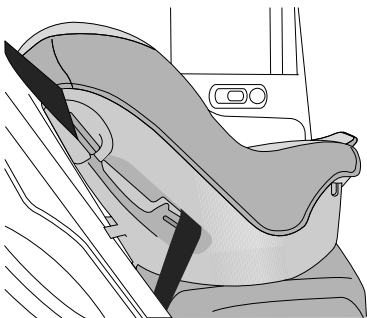

It is recommended that children should always be seated in the rear of the vehicle in a child restraint or restraint system, and fixed with 3 point, lap diagonal seat belts.

### ISOFIX Child Restraint Systems



**The ISOFIX anchorages in the rear seat are designed for use with ISOFIX systems only.**



**Child restraint anchorages are designed to withstand only those loads imposed by correctly fitted child restraints. Under no circumstances are they to be used for adult seat belts, harnesses, or for attaching other items or equipment to the vehicle.**

**Note:** When installing and using any child restraint system, always follow the manufacturer's instructions.

**Note:** The rear seats fitted to this vehicle are provided with the ISOFIX interface (as indicated by the arrow in the following image), these are designed to connect to an ISOFIX child seat.

- 1 Fasten vehicle-approved ISOFIX child restraint systems to the mounting brackets.
- 2 When using ISOFIX mounting brackets for seat mounting, universally approved child restraint systems for ISOFIX may be used.

## SEATS & RESTRAINTS

**Note:** When using seat mounting, universally approved child restraint systems, top tether must be used.

**Note:** Please refer to the child restraint system manufacturer's instructions for details.

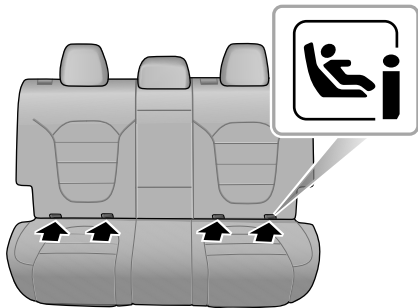

- 3 To fasten the top tether strap of the child restraint system, route the tether strap under the head restraint and attach to the anchorage hook being careful not to

twist the strap. If not using ISOFIX lower anchorages, using the seatbelt, complete the installation in line with the child restraint manufacturers instructions.

- 4 After installation apply suitable force to ensure the restraint is securely fastened.

**Note:** When installing and removing any child restraint system, always follow the manufacturer's instructions.

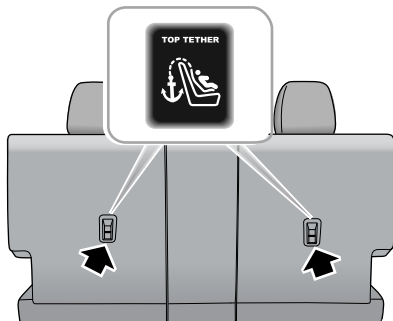



## Approved Child Restraint Positions

It is recommended that a child restraint system that complies with UN ECE-R44 or ECE-R129 standard are fitted in this vehicle. Check markings on the child restraint system.

## Approved Child Restraint Positions (for non ISOFIX Child Restraints)

Mass Group	Seating Positions				
	Front Passenger			Rear Outboard	Rear Middle
	Without Front Passenger Airbag OFF Switch	With Front Passenger Airbag OFF Switch			
		Airbag ON	Airbag OFF		
0 group (less than 10 kg)	X	X	U	U	U
0+ group (less than 13 kg)	X	X	U	U	U
I group (9 ~ 18 kg)	X	X	U	U	U
II group (15 ~ 25 kg)	U	U	U	U	U
III group (22 ~ 36 kg)	U	U	U	U	U

Note: Description of letters in the table:

U = Suitable for universal child restraint systems approved for this mass group;

X = Seat position not suitable for child restraint systems in this mass group.

## SEATS & RESTRAINTS

### Approved Child Restraint Positions (for ISOFIX Child Restraints)

Seating Position		Mass group categories			
		0 group	0+ group	I group	
		Rear facing		Forward facing	Rear facing
		Up to 29 lbs(13 kg)		20–40 lbs(9 ~ 18 kg)	
Front Passenger Seat	Size Class	Not ISOFIX equipped			
	Seat Type				
Rear Outboard Seat ISOFIX	Size Class	C,D,E <sup>1</sup>	A,B, BI <sup>1</sup>	C,D <sup>1</sup>	
	Seat Type	IL <sup>2</sup>	IL <sup>2</sup> ,IUF <sup>3</sup>	IL <sup>2</sup>	
Rear Centre Seat	Size Class	Not ISOFIX equipped			
	Seat Type				

Note: IL Suitable for particular ISOFIX child restraints systems of the semi-universal category. Please consult child restraints systems suppliers' vehicle recommendation lists;

IUF Suitable for ISOFIX forward facing child restraints systems of universal category approved for use in this mass group and ISOFIX size class;

<sup>1</sup>. The ISOFIX size class for both universal and semi-universal child seat systems is defined by the capital letters grade A ~ G. These identification letters are displayed on the ISOFIX child seat;

- <sup>2</sup>. At time of publishing the recommended Group 0+ ISOFIX baby safety seat is the Britax Romer Baby Safe. Consult an MG Authorised Repairer for the latest details relating to our recommended child seats;
- <sup>3</sup>. At time of publishing the recommended Group I ISOFIX child seat is the Britax Romer Duo. Consult an MG Authorised Repairer for the latest details relating to our recommended child seats.

Note: At time of publishing the recommended Group II-III ISOFIX child seat is the KidFix II XP SICT and KidFix<sup>2</sup> R. Consult an MG Authorised Repairer for the latest details relating to our recommended child seats.

### Table of I- Size child seats

The table gives a recommendation for which I- Size child seats suit which locations, and for what size of child.

The child seat must be approved in accordance with UN Reg R129.

Type of child seat	Front passenger seat	Rear outboard seats	Rear centre seat
I- Size child restraint systems	X	I-U	X

Note: I-U Suitable for use with forward and rear facing I- Size child restraint systems.

X Not suitable for use with I- Size restraint systems.

## SEATS & RESTRAINTS

---

### Group 0/0+ Child Restraint



*When the front passenger airbag is active, never place a rear facing child restraint on the front passenger seat, severe injury or even death can occur.*

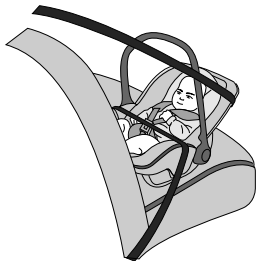

Child restraints that can be adjusted to lying position are most suitable for infants who are lighter than 10 kg (normally for those younger than 9 months) or those who are lighter than 13 kg (normally for those younger than 24 months).

### Group I Child Restraint



*When the front passenger airbag is active, never place a rear facing child restraint on the front passenger seat, severe injury or even death can occur.*

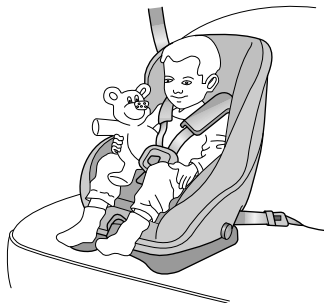

Backward/forward child restraints are most suitable for infants whose weight is 9 ~ 18 kg (normally for those older than 9 months and younger than 4 years old).

### Group II Child Restraint



*The diagonal section of the seat belt should pass across the shoulder and upper body, away from the neck. The lap section of the belt should pass across the hips, away from the abdomen.*



The combination of child restraint and 3 point lap diagonal seat belt is most suitable for children whose weight is 15 ~ 25 kg (normally for those older than 3 years old and younger than 7 years old).

### Group III Child Restraint



*The diagonal section of the seat belt should pass across the shoulder and upper body, away from the neck. The lap section of the belt should pass across the hips, away from the abdomen.*



The combination of child booster seat and vehicle 3 point lap diagonal seat belt is most suitable for children whose weight is 22 ~ 36 kg and whose height is below 1.5 m (normally for those about 7 years old or those older than 7 years old).



## Starting & Driving

---

- 154 Keys
- 158 Child Proof Locks
- 159 Alarm Systems
- 169 Starting and Stopping Engine
- 173 Economical and Environmental Driving
- 176 Catalytic Converter and Particulate Filter
- 178 Fuel System
- 181 Manual Transmission \*
- 183 Dual Clutch Automatic Transmission \*
- 189 Driving Mode \*
- 192 Brake System
- 204 Stability Control System (SCS) and Traction Control System (TCS)
- 206 Tyre Pressure Monitoring System (TPMS)
- 207 STOP-START Intelligent Fuel Saving System
- 212 Cruise Control System \*
- 215 Adaptive Cruise Control System \*
- 225 Parking Aid System \*
- 227 Rear Driver Assistance System
- 235 Driving Assist System
- 266 Load Carrying

# STARTING & DRIVING

## Keys

### Overview



**Please keep the spare key in a safe place - not in the car!**



**It is recommended that spare keys are not kept on the same key ring, since this may cause interference and prevent correct key recognition and therefore prevent the correct operation of the vehicle power system.**



**The smart key contains delicate circuits and must be protected from impact and water damage, high temperature and humidity, direct sunlight and the effects of solvents, waxes and abrasive cleaners.**

Your vehicle is supplied with two smart keys, each one contains a back up mechanical key blade, this will operate the driver door mechanical lock. The smart keys supplied are programmed to the security system on the car, any key that is not programmed to the car will not operate the keyless entry function or the vehicle immobiliser.

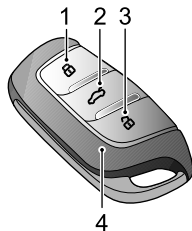

- 1 Lock Button
- 2 Tailgate Button
- 3 Unlock Button
- 4 Smart Key

The smart key only works within a certain range. Its working range is sometimes influenced by the key battery condition, physical and geographical factors. For safety consideration, after you lock your vehicle by the smart key, please recheck if the vehicle is locked.

If your key is lost/stolen or broken, a replacement can be obtained from an MG Authorised Repairer. The lost/stolen



key can be deactivated. If the lost key is found, an MG Authorised Repairer can reactivate it.

**Note:** *Any key made independently outside of MG Authorised Repairer Network may not start the engine, and may affect the safety of your car. To obtain a suitable key replacement, it is recommended that you can consult MG Authorised Repairer.*

**Note:** *The new key cannot be offered to you immediately because it requires programming to the vehicle by the MG Authorised Repairer.*

**Note:** *When operating your vehicle with the smart key, avoid placing it near the devices with strong radio interference (such as notebook computers and other electronic products), the normal function of the key may be affected.*

### Replacing the Battery

Please use the picture guide to replace the smart key battery if any of the following conditions occur:

- The smart key locking/unlocking function range is reduced;
- The engine immobilisation warning lamp on the instrument pack flashes. The corresponding alarm icon (refer to "Warning Lights and Indicators" in "Instruments and Controls" chapter) will be shown on the message centre display. "Smart Key Not Found" may be displayed for some models.

## STARTING & DRIVING

---

A



B



C



D



- 1 Press the button (A) on the smart key to eject the decorative trim.
- 2 Remove the backup mechanical key (B) in the arrowed direction.
- 3 Using a suitable flat bladed tool, insert the tool into the side of the key (C), carefully prise off the battery cover and separate the upper and lower casings (D).
- 4 Remove the battery from the slot.

- 5 Put the new battery in the slot, and make sure it is in full contact with the slot.

**Note:** Make sure that the polarity of battery is correct ('+' side facing down).

**Note:** It is recommended to use a CR2032 battery.

- 6 Refit the cover and press tightly, ensuring the gap around the cover is even.
- 7 Refit the mechanical key, and close the decorative trim.
- 8 Start the engine to resynchronise the key with the vehicle.

### IMPORTANT

- Use of an incorrect or inappropriate battery may damage the smart key. The new replacement's rated voltage, sizes and specifications must be the same as the old one.
- Incorrect fitting of the battery may damage the key.
- Disposal of the used battery must be strictly in accordance with relevant environmental protection acts.

## STARTING & DRIVING

---

### Child Proof Locks



**NEVER leave children unsupervised in the car.**

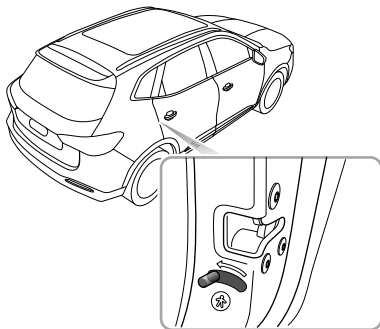

Steps for enabling or disabling the child proof locks are as follows:

- Open the rear door at corresponding side, move the child proof lock lever to the lock position in the direction of the arrow to engage the child proof lock;

- Move the lever to the unlock position in the reverse direction of the arrow to disable the child proof lock.

With the child proof lock locked, the rear door at the corresponding side cannot be opened from inside the car, but can be opened from outside the car.

### Alarm Systems

Your vehicle is fitted with an engine immobiliser system and a vehicle anti-theft system. To ensure maximum safety and operation convenience, we strongly recommend you to carefully read this chapter to fully understand the activation and deactivation of anti-theft systems.

### Engine Immobiliser

An engine immobiliser is designed to safeguard the vehicle from theft. Engine immobilisation can only be deactivated to start the car by using the matched key.

Press START STOP button on the instrument panel, once a valid key is detected in the vehicle, engine immobiliser will be deactivated automatically.

If the message centre displays "Smart Key Not Found" or "Please Put the Key in Alternative Starting Position" or the engine immobiliser system warning lamp illuminates, please put the smart key at the bottom of the centre console cup holder (refer to "Alternative Starting Procedure" in "Starting and Stopping Engine" section), or try to use the

spare key. If the car can still not be started, seek an MG Authorised Repairer.

# STARTING & DRIVING

---

## Vehicle Anti-theft System

### Locking and Unlocking

When the vehicle is locked, the indicator lamps flash three times, and the anti-theft system warning lamp flashes (model dependant) ; when it is unlocked, the turn signal lamps flash once. On some models, you can unlock all doors or the driver door using the Car settings on the infotainment display.

### Operation of Door Lock System (Key)

#### Key Locking

- Using the remote key to lock: press the lock button on the key to lock the car after closing the doors, engine bonnet and tailgate.
- Using the mechanical key to lock: partially operate the door release handle, using a suitable flat blade tool, insert the tool into the underside of the trim and carefully remove the door lock trim cover, insert the key into the driver door lock and turn counterclockwise to lock the car.

#### Key Unlocking

- Using the remote key to unlock: press the unlock button on the key to unlock the car.
- Using the mechanical key to unlock: partially operate the door release handle, using a suitable flat blade tool, insert the tool into the underside of the trim and carefully remove the driver door lock trim cover, insert the key into the driver door lock and turn clockwise to unlock the car.

**Note:** *If the start/stop switch is not placed in ACC or ON/RUNNING position or the remote key unlock is not activated within 15 seconds after the vehicle is unlocked with the mechanical key, the immobiliser alarm will be triggered.*

**Note:** *If no panels are opened within 30 seconds after the vehicle is unlocked by using the remote key, all doors will automatically re-lock.*

### Operation of Door Lock System (Keyless)

The keyless entry system can lock and unlock the doors or open the tailgate as long as you carry the smart key and approach to the car.

### IMPORTANT

The smart key must be within 1.5 metres of the vehicle for the keyless system to operate correctly

### Keyless Locking

After switching off the engine using the START/STOP button and exiting the car, press the door handle button once before moving away from the car to lock all doors and tailgate (no need to press the lock button on the key). Note, this will also arm the alarm and immobilise the vehicle.

### Keyless Unlocking

Press the button on the front door handle once to unlock the car, then pull the door handle to open the door.

**Note:** When the vehicle is locked, if you are within the smart key range and operate the door handle button, but carry out no further action, after 30 seconds the vehicle will automatically re-lock itself to remain secure.

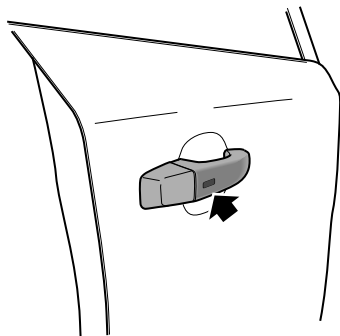

### IMPORTANT

After the door is locked by using the key, press the button on the door handle to unlock the car. If the car cannot be unlocked or locked normally, seek an MG Authorised Repairer.

# STARTING & DRIVING

---

## Mislock

If the driver's door is not fully closed when the smart key lock button is pressed, or the vehicle ignition system has not been switched OFF, the vehicle horn will sound once, indicating a mislock. In this case, none of the doors will lock, the alarm system will not be armed and the direction indicator lights will not flash.

If locking operation is performed when the driver's door is closed but the passenger's door or bonnet and tailgate are not fully closed, the vehicle horn will sound once, indicating a mislock. In this case, the 'partial arming' attributes of the body anti-theft system will enable (all fully closed doors, bonnet or tailgate apertures will be protected, but an open aperture will not! ). As soon as the open aperture is closed, the system will automatically revert to an armed state.

## Inadvertent Locking of Keys in Vehicle

If the vehicle is locked using the mechanical key blade or handset whilst a smart key/s remain inside, the following actions will occur:

- One smart key locked in the vehicle - The immobilisation release function of the smart key locked in the vehicle is suspended, the lock and unlock function of the smart key is retained. The engine cannot be started. To reinstate the immobiliser release function of the smart key locked in the vehicle the second smart key should be used to unlock the vehicle. The function will automatically be reinstated.
- Both smart keys locked in vehicle - The immobilisation release function of both smart keys locked in the vehicle is suspended, the lock and unlock function of the smart keys is retained. The engine cannot be started. The reinstatement of key functions can only be carried out using the approved diagnostic tool. Consult an MG Authorised Repairer immediately.

## Anti-Theft Alarm Sounder

If the anti-theft alarm has been triggered, the car horn will sound continuously. Press the UNLOCK button on the key, the anti-theft alarm will be deactivated.



### Interior Lock and Unlock Switch

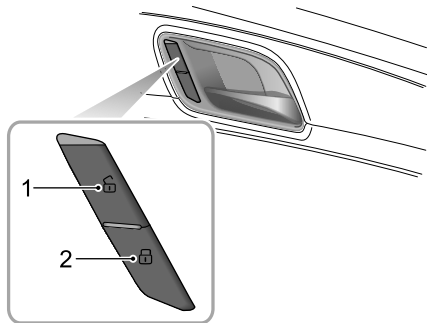

- 1 Unlock Switch
- 2 Lock Switch

When the vehicle anti-theft system is not set, press the lock switch (2) after closing all doors to lock all doors; press the unlock switch (1) to unlock all doors.

**Note:** If the vehicle anti-theft system is set, pressing the lock/unlock switch will not lock/unlock the doors but will trigger the alarm system.

If the doors, bonnet and tailgate are closed, press the interior lock switch, the yellow indicator on the interior lock switch illuminates.

If a mislock is caused by non-driver door, tailgate or bonnet, press the interior lock switch, the yellow indicator on the interior lock switch illuminates.

### Interior Door Handles

Use the interior door handles to open the door:

- 1 Pull the interior door handle once to unlock the door.
- 2 Pull the interior door handle again to open the door.

### Speed Lock

All the doors will be locked automatically when the road speed exceeds 10 mph ( 15 km/h ) .

# STARTING & DRIVING

---

## Automatic Unlock

When the vehicle power system is switched to the OFF position, all the doors will be unlocked automatically.

## Manual Tailgate \*



*If the tailgate can not be closed due to the type of cargo loaded, be sure to close all windows during driving, select the face distribution mode of the air condition, and set the blower to maximum speed, so as to decrease exhaust fumes entering the vehicle.*

Manual tailgate can be opened by the following 2 ways:

- 1 When the car is unlocked or the matched key appears within 1m range around the tailgate, directly press the open switch on the tailgate to open the tailgate (A).
- 2 Press and hold the open button (B) for more than 2 seconds to unlock and release the tailgate, then manually lift to open the tailgate.

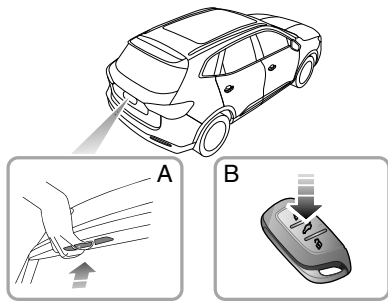

### Electric Tailgate \*



*If the tailgate can not be closed due to the type of cargo loaded, be sure to close all windows during driving, select the face distribution mode of the air condition, and set the blower to maximum speed, so as to decrease exhaust fumes entering the vehicle.*



*Before operating the electric tailgate, ensure no persons, animals or obstructions are within the direct vicinity of the tailgate, they may become trapped between the tailgate and vehicle or tailgate and obstacle. Ensure any items carried in rear of vehicle have adequate clearance from the tailgate when closing.*

The electric tailgate will only operate when the vehicle is not running and Park is selected.

Whilst the electric tailgate is operating the system will emit an audible warning.

## STARTING & DRIVING

### Electric Tailgate Open/Close Mode

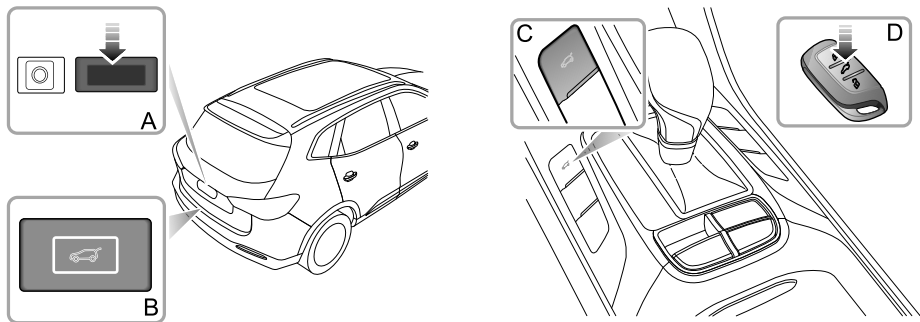

Electric tailgate can be opened or closed using the following methods:

- 1 **Open/Close from outside** : When the vehicle is unlocked or matched key appears within 1 m range around the tailgate, press button A to open the tailgate, press button B to close.
- 2 **Open/Close by smart key** : When START STOP switch is in the OFF position, press and hold the tailgate button D on the smart key to automatically open or close the tailgate.
- 3 **Open/Close from inside** : Press and hold the tailgate switch button C on centre console to automatically open or close the tailgate. (If the vehicle is locked from the outside, switch button C will not operate.)

**Note:** *In certain conditions where the vehicle has been stopped or parked on an extreme incline, the tailgate may not be electrically opened or fully closed due to the change of centre-of-gravity position.*

If the tailgate fails to fully open to its preset height, or fully close, carry out a manual operation to close the tailgate, this will restore the electric tailgate operation.

**Note:** *During manual operation of electric tailgate, avoid violent or rapid operation, failure to follow these instructions may result in damage to the power tailgate system.*

When the tailgate is fully closed it will lock in position using the electric catch.

### Anti-pinch Function

**Whilst opening the tailgate:** In cases where an object that interferes with the tailgate operation is detected, the tailgate will stop opening and return to a safe angle automatically where the obstruction/s can be removed.

**Whilst closing the tailgate:** In cases where an object that interferes with the tailgate operation is detected,

the tailgate will stop closing and return to a safe angle automatically where the obstructions can be removed.

**Note:** *If the anti-punch function has been activated multiple times in a brief period, the system will suspend the electric opening/closing function for protection. In this situation, the tailgate can be fully closed once manually so as to reset the function of electric tailgate.*

**Note:** *If the tailgate is frequently operated in a short period, the system thermal protection may be triggered, causing the electric opening/closing function to be temporarily unavailable. Operation will be suspended for a preset time limit.*

### Setting Opening Height for Electric Tailgate

Users can set the opening height of electric tailgate as needed by using the Close button on the tailgate or Infotainment screen. The electric tailgate controller will record the new opening height.

**Note:** *The setting value of opening height of the electric tailgate must be between 40% and 100% of its total stroke.*

## STARTING & DRIVING

---

### Setting mode 1:

- 1 Place the tailgate to desired setting height, and keep it stationary.
- 2 Press and hold the Close button on the tailgate for a minimum of 3 seconds. A buzzer will sound to indicate the successful setting.

### Setting mode 2:

Turn on the Infotainment system, enter the height setting interface for electric tailgate under "Setting" menu, and move the height setting slider to desired position.

**Note:** *If an electric tailgate system failure occurs, a relevant warning message "Power Liftgate System Fault" and icon will be displayed in the message centre of the instrument pack, please consult an MG Authorised Repairer.*

### Tailgate Emergency Open

The tailgate emergency open switch is located in the inner side of tailgate lock.

Fold down the rear seat to gain access, remove the blanking plug, insert a suitable tool into the opening slot and release the tailgate lock.

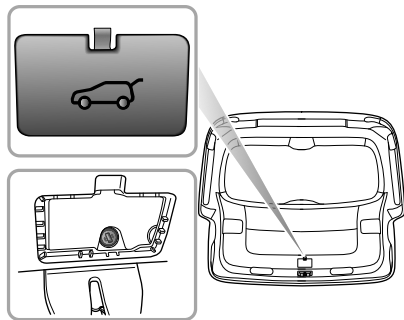

### Starting and Stopping Engine

#### START/STOP Switch



The keyless START/STOP Switch is located in the fascia to the right of the steering column, it is a push button style switch. To operate the switch the smart key must be inside the vehicle.

The operational status displays are as follows:

#### **Indicator Off (OFF)**

- If the switch has not been operated and there are no indicators illuminated, the power system is OFF. The power seats and electric door mirrors remain operational.

#### **Yellow Light (ACC)**

- Pressing the START/STOP Switch without the footbrake being applied whilst the switch is in the OFF position will place the vehicle in the ACC state, this will illuminate the yellow indicator in the switch button. The ACC position allows operation of certain ancillaries such as power windows.

#### **Green Light (ON/RUNNING)**

- Whilst in the ACC state, pressing the START/STOP Switch without the footbrake being applied will place the system in the ON state, the green indicator will illuminate. This will allow the remaining electrical systems to operate.
- Pressing the START/STOP Switch with Park or Neutral selected and the footbrake/clutch pedal applied will start the engine, the green indicator will illuminate. This indicates that all electrical systems will operate.

## STARTING & DRIVING

---

**Note:** Whilst in the OFF state, if the driver exits the vehicle leaving the smart key inside, the horn will sound on closure of the driver's door. Subsequent re-opening of the driver's door will cause a buzzer to sound, a warning icon will illuminate and a warning message will be displayed in the instrument pack message centre to indicate that the key is still in the car.

**Note:** To remove the vehicle from Park, the vehicle must be in an ON/RUNNING state and the footbrake applied.

If your car is subject to strong radio signals the keyless entry and start systems may suffer from interference and not function correctly. Please see the 'Alternative Starting' procedure.

### Starting the Engine

#### Starting the Engine:

- 1 Ensure all unnecessary electrical loads are switched off.
- 2 Ensure the parking brake is applied. (refer to "Brake System" of this chapter)
- 3 For auto transmission vehicles, Ensure P or N is selected and press the brake pedal (If the shift lever is in any other position, the engine cannot be started.)
- 4 For manual transmission vehicles, ensure neutral is selected and the clutch pedal is fully pressed.
- 5 Press the START/STOP Switch (do not hold the button in, release immediately).
- 6 The green indicator will illuminate.

### Cold Climates

In temperatures of  $-10^{\circ}\text{C}$  and below, engine cranking time will increase. It is essential that all unnecessary electrical equipment is switched off while cranking.



### IMPORTANT

- If the vehicle will not enter a ON/RUNNING state, please check for any warning indicators or messages displayed in the instrument pack message centre. In extremely low temperatures please allow 5 minutes between power up attempts, if after 3 attempts the vehicle will not start please consult an MG Authorised Repairer or breakdown service.
- Do not leave the power system in an ACC or ON/RUNNING state for long periods of time, excessive use of electrical equipment may lead to a discharged battery.
- The vehicle is fitted with an anti-theft system. Independently sourced keys may not allow vehicle start the engine. Any new keys will require programming using the manufacturers software.
- Your car is fitted with complex electronic control systems, please ensure that all other radio transmission or electromagnetic devices are kept away from the smart key and centre console cubby areas. They may cause interference and operational issues. Please see the 'Alternative Starting' procedure.

### Alternative Starting Procedure

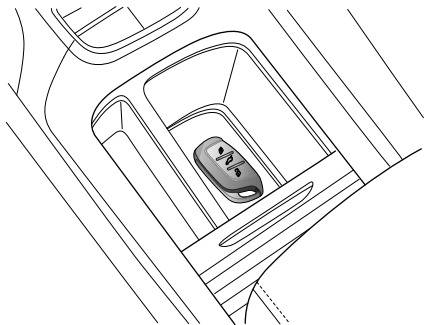

If the car is located in an area where there are strong radio signals causing interference or the smart key battery condition is low, please use the following steps to attempt to start the car:

- 1 Place the smart key centrally in the centre console cup holder cubby box with the buttons facing upward - as shown in the illustration.

## STARTING & DRIVING

---

- 2 Ensure P or N is selected, press the brake/clutch pedal and then press START/STOP Switch to start the vehicle.

If the immobiliser cannot be released after the car has left the area of strong radio interference or had the smart key battery replaced please consult an MG Authorised Repairer.

### IMPORTANT

The Alternative Starting Procedure should only be required if the smart key battery is very low or flat. Once the vehicle has been removed from the area of excessive radio interference the keyless entry and STOP-START systems should return to normal.

### Stopping the Engine

- 1 After bringing the car to a halt, ALWAYS maintain brake pedal application.
- 2 Apply the parking brake;
- 3 For vehicles with automatic transmission, place the shift lever in P position;
- 4 For vehicles with manual transmission, place the shift lever in N position;
- 5 Press START/STOP Switch to shut down the engine.

**Note: Should the engine require to be shut down in the case of an emergency, press and hold the START/STOP Switch in excess of 4 seconds.**

## Economical and Environmental Driving

### Running-in

The engine, transmission, brakes and tyres need time to 'bed-in' and adjust to the demands of everyday motoring. During the first 900 miles, please heed the following advice so as to enhance the long-term operation performance:

- Do not allow the engine to exceed 3000 rpm in any gear or the vehicle speed to exceed 72 MPH.
- Do not operate at full throttle or allow the engine to labour in any gear.
- Do not drive at a constant speed (either high speed or low speed).
- Avoid heavy braking where possible.

After 900 miles, engine speeds can be gradually increased.

### Environment Protection

Your vehicle has been designed with the latest technology in order to minimize the environmental impact of exhaust emissions.

## Economic Driving and Maintenance

The following are some suggestions on saving fuel and extending the life of the vehicles.

- Maintain the correct tyre pressure; insufficient air pressure will accelerate tyre wear and waste fuel.
- Do not carry unnecessary weight. Heavy loads will increase the engine load resulting in higher fuel consumption.
- Avoid engine idling for extended periods.
- Maintain slow and smooth acceleration and avoid harsh acceleration; change to a higher gear as soon as possible.
- Avoid labouring the engine or over running. Choose appropriate gears according to the road conditions.
- Avoid continuous acceleration or deceleration. A stop-go driving style will consume more fuel.
- Avoid unnecessary stopping and braking, maintain steady speed and attempt to anticipate traffic lights.

**Note:** *Keep an appropriate distance from other vehicles to avoid emergence braking and reduce brake pad wear.*

## STARTING & DRIVING

---

- Avoid traffic congestion and jam areas as much as possible.
- Anticipating obstructions and slowing down well in advance, avoids the need for unnecessary acceleration and harsh braking. A smooth driving style not only reduces fuel consumption, but can reduce the emission of noxious gases.
- Do not ride the brake pedal, this can cause premature wear, overheating and increased fuel consumption.
- Maintain an appropriate speed on the highway. Higher speeds use more fuel. Appropriate speed can save fuel.
- Maintain the correct wheel alignment. Avoid collision with the kerb and reduce speed on uneven road surfaces. Out of specification wheel alignment will not only lead to excessive tyre wear, but also increases the engine load and fuel consumption.
- Avoid driving on mud or beaches. This will prevent corrosion of the vehicle underside.
- Maintain the vehicle in accordance with MG recommendations. Dirty air filters, oil etc., will reduce the engine's performance and raise fuel consumption.

**Note: To extend the life of all components and reduce operating costs, regular MG Approved maintenance is needed.**

- Do not stop the engine straight after high speed or long ascents or towing a trailer. Allow the engine to idle for 20 to 100 seconds depending upon driving loads and conditions. Avoid hard acceleration on a cold engine.

## Driving in Special Environment

### *Driving in Rain or Snow*



***Emergency braking, accelerating and steering on slippery roads will reduce the vehicle's handling performance and grip.***

- When raining the windows may fog, reducing visibility (Use the Air-conditioning demist function).
- Grip will be reduced when it rains, so please reduce speed drive carefully.
- Reduce speed when it rains.
- Avoid driving in high speed, because the film of water between the tyres and the road will affecting the steering and braking performance.

### ***Driving through Water***

Avoid driving through floods after heavy rain, which may lead to serious damage to the vehicle.

## STARTING & DRIVING

---

### Catalytic Converter and Particulate Filter



*The temperatures of exhaust systems that contain particulate filters and catalytic converters can be extremely high, DO NOT park on ground where combustible materials such as dry grass or leaves could come into contact with the exhaust system - in dry weather a fire could result.*

The exhaust system incorporates a catalytic converter and particulate filter, which converts poisonous exhaust emissions from the engine into environmentally less harmful gases. Catalytic converter and particulate filter are easily damaged through improper use, please observe the following precautions to minimise the chance of accidental damage.

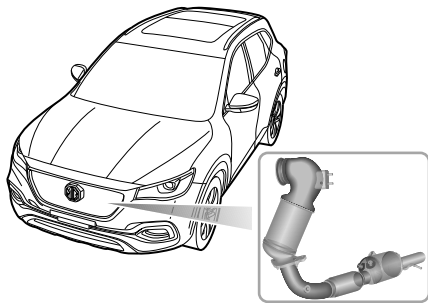

#### **Fuel**

- Use **ONLY** fuel recommended for your car.
- Never allow the car to run out of fuel – this could cause engine misfire and serious damage to the catalytic converter and particulate filter.

### Starting

Pay attention to the followings when starting the engine:

- Do not continue to operate the starter after a few failed attempts; seek MG Authorised Repairer.
- Do not operate the starter if an engine misfire is suspected and do not attempt to clear a misfire by pressing the accelerator pedal.
- Do not attempt to push or tow start the car.

### Driving

Please pay attention to the following conditions:

- Do not overload or excessively 'rev' of engine.
- Do not stop the engine when the car is in motion with D or a gear selected.
- Seek MG Authorised Repairer if you think your car's oil consumption is abnormal.
- If a misfire is suspected, or the car lacks power while driving, provided the engine has reached its normal operating temperature, it may be driven SLOWLY (at risk of catalyst and particulate filter damage) to an MG Authorised Repairer.

- Do not drive on terrain likely to subject the underside of the car to heavy impacts.

**Note: Any engine misfire, loss of engine performance or engine run-on, could seriously damage the catalytic converter and particulate filter. Regular maintenance must be carried out in accordance with the schedule specified in the 'Service Portfolio'. Any modifications to engine without being authorised is prohibited.**

### Engine Oils

- It is recommended that only oils that meet the manufacturers specification are used. Use of oils that do not meet the manufacturers specifications can damage the particulate filter, for example low SAPS oils can affect particulate filter ash capacity.

# STARTING & DRIVING

---

## Fuel System

### Fuel Requirements



*Use only the recommended fuel which meets national standard! Serious damage to the catalytic converter, a reduction in engine power/torque and increase in fuel consumption will occur if the wrong fuel is used.*

Use the fuel recommended by the manufacturer. See "Main Parameters of Engine" in "Technical Data" chapter.

If a lower grade of fuel is used, an engine knocking noise may occur, please use the recommended or above grade fuel as soon as possible. If the engine knocking noise is still noticeable after using the recommended or above grade fuel, please contact MG Authorised Repairer immediately. It is permitted that fuel can be used with a higher octane rating than that required by the engine, but it is not advantageous for engine output power and fuel consumption.

### Safety Precautions in a Fuel Filling Station



*Vehicle fuel gases are highly flammable and, in confined spaces, are also extremely explosive.*

Always take care when refueling:

- Switch off the engine.
- Do not smoke or use a naked flame.
- Do not use a mobile phone.
- Avoid spilling fuel.
- Do not overfill the tank.



### Fuel Filler

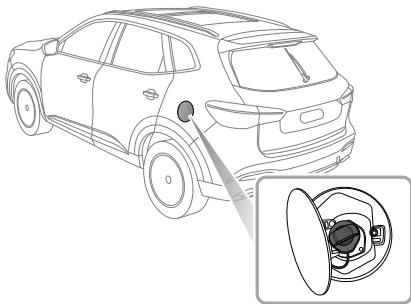

### Fuel Filler Flap

The fuel filler flap is located on the rear left-hand wing. Its lock is connected with central control door lock system. Press the right side of the flap to open it when the door is unlocked.

**Note:** *The fuel filler flap will only be locked when the doors are locked.*

### Fuel Filler Cap

Slowly unscrew the filler cap anti-clockwise and allow any pressure inside the tank to escape, before removing the cap.

After refueling, tighten the filler cap clockwise until you hear 1 "click" sound.

If the fuel filler cap is left loose or the seal is damaged the engine malfunction warning light in the instrument pack will illuminate, please secure the cap or seal. If the lamp remains illuminate consult an MG Authorised Repairer.

### Refueling

Do not fully fill the tank if the vehicle is to be parked in direct sunlight, or high ambient temperature - expansion of the fuel could cause spillage. The fuel filler tube is designed to accept a narrow, long filler nozzle. There is a cover at the filler neck, by inserting the filler nozzle thoroughly before fuel filling, the cover can be fully opened.

Start the engine after fuel filling. After refueling, if the engine runs unevenly, switch off and seek an MG

## **STARTING & DRIVING**

---

Authorised Repairer before attempting to restart the engine.

## Manual Transmission \*

### Gear Shift Lever

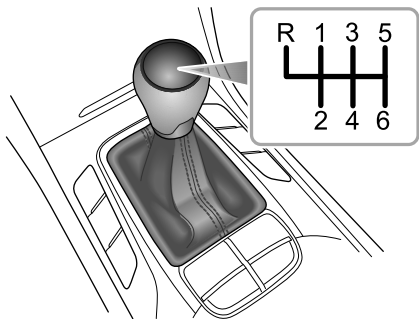

The manual transmission is a 6-speed transmission with 7 gears, which are: 1st, 2nd, 3rd, 4th, 5th, 6th and R (Reverse) respectively. All gears have synchromesh.

### Precautions while driving:

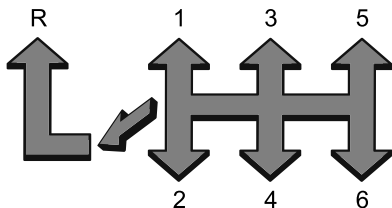

- 1 When selecting Reverse gear, you must ensure that the vehicle is completely in stationery, wait for a moment and then fully press the clutch pedal, from the N position, press the lever down and push it leftward, then push it forward into the R position, slowly release the clutch pedal to complete the gear shift.
- 2 Do not rest your hand on the gear shift lever while driving - pressure from your hand may cause premature wear to the gear selector mechanism.
- 3 Do not rest your foot on the clutch pedal when driving - excessive wear to the clutch will result.

## STARTING & DRIVING

---

- 4 Do not hold the car stationary on a hill by slipping the clutch. This will wear out the clutch.

### **Gear Display and Gear Shift Indications**

When the vehicle is stationary and N gear is selected, the information centre will display N.

When Reverse gear is selected, the information centre will display R.

When the vehicle is in motion and the clutch pedal is fully released, if the selected gear is inappropriate, the information centre will display the target gear (1-6) and an Up/Down arrow indicating to the driver to either upshift or downshift to the displayed gear when driving conditions permit.

***Note: Gear shift indications are advisory and for information only. Gear shift operation should be carried out on the premise that your own safety is guaranteed and the traffic regulations are observed.***

### Dual Clutch Automatic Transmission \*

#### Instructions

The following information is very important, please read carefully before use:

- Before starting the engine, ensure the doors are closed, place the gear lever in P or N position, ensure the foot brake is pressed and parking brake is applied.
- After the engine has started, ensure the foot brake and electronic parking brake are applied, shift the lever to the required gear.
- Release the electronic parking brake system and hold the foot brake until you are ready to manoeuvre the vehicle. Once the foot brake is released, on flat road, the vehicle will automatically start off at a slow speed without application of the accelerator.
- During driving DO NOT coast in neutral, it could damage the transmission or cause an accident.

### Electronic Shift Lever

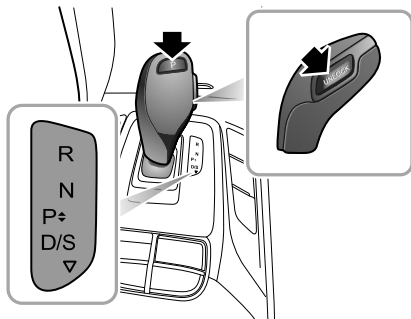

The dual clutch automatic transmission is a 7-speed transmission.

**Note:** The highlighted letter or number in the information centre indicates the selected gear or mode.

The Electronic Shift Lever features a P (Park) button on the top and an UNLOCK button on the side.

# STARTING & DRIVING

---

## Operation of Electronic Shift Lever



Unless necessary, it is not recommended to press **UNLOCK** button during gear shifting. This may allow inadvertent gear lever movement and incorrect gear selection causing possible damage.

The Electronic Shift Lever defaults to the middle steady-state. The forward and backward positions are non-steady states.

**Note:** To move out of **P** or to move into Reverse, the foot brake must be depressed and the **UNLOCK** button must be pressed simultaneously.

## Transmission Gears

- P: Park

Depress the foot brake and wait until the vehicle is stationary, press the P button to enter P gear.

In this position, the transmission is mechanically locked. Engage this gear only when the vehicle is stationary and the EPB system is applied.

To park the vehicle on a slope, depress the foot brake, apply the EPB system, then shift to P position.

When the vehicle is stationary, operating the start/stop switch to the OFF position will cause the vehicle to enter P position automatically.

When the vehicle is stationary, if the foot brake is not applied, the driver's seat belt is released and the driver's door is opened, the vehicle will enter P position automatically.

- R: Reverse

Depress the foot brake, press and hold the UNLOCK button, push the electronic shift lever forward to the end, the vehicle will enter Reverse.

Select this gear only when the vehicle is stationary.

- N: Neutral

When in Park, depress the foot brake, press and hold the UNLOCK button, push the electronic shift lever forward or backward to the first non-steady state position, the vehicle will enter Neutral.

Whilst D/S is selected, push the electronic shift lever forward to the first non-steady state position, the vehicle will enter Neutral.

In Reverse, pull the electronic shift lever backward to the first non-steady state position, the vehicle will enter Neutral.

Select this gear when the vehicle is stationary and the engine is running at idle speed for a long time (for example, waiting at traffic lights).

- **D: Drive**

Whilst in Park, depress the foot brake, press and hold the UNLOCK button, pull the electronic shift lever backward to the end, the vehicle will enter Drive.

In R\N\S , pull the electronic shift lever backward to the end, the vehicle will enter Drive.

It is used for normal driving and will allow automatic selection of 7 forward gears depending on vehicle speed and accelerator position.

In Drive, the automatic transmission will enter standard mode and the information centre displays “D”.

- **S: Sport Mode**

In Drive, pull the electronic shift lever backward, the vehicle will enter Sport mode and the information centre displays “S”.

Whilst in Sport mode, the transmission upshifts later, so as to make full use of the power reserves of the engine. When more acceleration is required, select Sport mode, but please note that the fuel consumption will be increased.

To exit Sport mode, pull the electronic shift lever backward.

### **Gearshift Speed**

Selecting D or S will allow the transmission controller to carry out gearshifts whilst considering a number of factors including engine speed, vehicle speed and accelerator position. Light accelerator pedal application will result in a gear-change at low speeds, larger pedal applications will result in gear-changes at higher speeds.

## STARTING & DRIVING

### Kick-down



*The drive wheels may skid when kick-down is activated on road surfaces with low adhesion, this may lead to the vehicle sliding out of control.*

With D or S gear selected, pressing the accelerator pedal all the way down in one motion (also known as Kick-down) will provide better acceleration performance during overtaking. Under certain conditions, it will allow the transmission to shift to a lower gear immediately, and provide fast acceleration. Once the accelerator pedal is released, it will resume a suitable normal gear (based on the vehicle speed and the position of the accelerator pedal).

### Manual Mode \*

Whilst Sport mode is selected, the paddle switches located on the steering wheel can be toggled to enable Manual mode. The current gear position (1 to 7) will be displayed in the information centre.

Press the "+" paddle switch to upshift to the next available high gear and press the "-" paddle switch to downshift to the next available low gear.

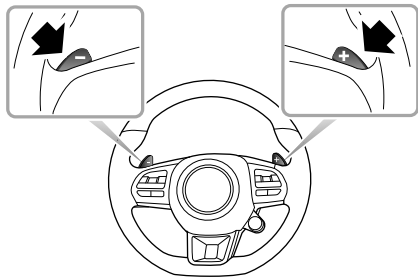

Whilst in Manual mode, if the driver makes an unreasonable gear selection, requests an upshift during low engine speeds, or requests a downshift during high engine speeds, the transmission will not respond and will remain in the current gear. If the vehicle is driven and the engine



speed falls below a preset threshold in certain gears, the transmission will automatically shift down to the next gear to avoid engine stalling; when the vehicle accelerates, if the engine speed exceeds a preset limit, the transmission will automatically shift up to the next gear to protect the engine.

Whilst in Manual mode, if the selected gear is inappropriate, the information centre will provide gear shift indications. An Up/Down arrow is displayed above/under the figure, indicating to the driver to either upshift or downshift when driving conditions permit.

**Note:** *Gear shift indications are advisory and for information only. Gear shift operation should be carried out on the premise that your own safety is guaranteed and the traffic regulations are observed.*

To exit Manual mode, pull the electronic shift lever backward.

### Protection Mode



**When parking, drive the vehicle to a safe area on the premise that your own safety is guaranteed and the traffic regulations are observed.**

### Overheating Protection of Automatic Transmission

Starting off frequently at high ambient temperatures may cause high transmission temperatures. In order to prevent damage, the system will perform an overheating protection routine, the information centre will display the relevant icon and messages accompanied by an audible alarm. Depending on the severity of the overheating, the warning messages may request the driver to "Increase Speed or Stop Safely", or "Stop Safely" (if circumstances allow).

With the transmission overheating, the warning message showing "Stop Safely" and the engine emission malfunction indicator lamp on, please park safely and shift the lever to P to allow the transmission to cool, the information centre will display "Please Wait", during this time the

## STARTING & DRIVING

---

engine can be switched off, vehicle exited and locked. Only when the transmission temperature has decreased and the information centre displays "Ready for Drive Away" can the vehicle start off.

If the driver adheres to the instructions displayed in the information centre for 20 minutes and the warnings have not altered or disappeared, seek an MG Authorised Repairer immediately.

### Limp Mode

When some failures occur the transmission will enter Limp Mode and will only function in some gears, in some cases it may fail to Reverse, during this time the information centre will display the engine emission malfunction indicator lamp. Seek an MG Authorised Repairer immediately.

**Note: In limp mode, Manual mode is disabled.**

### Severe Functional Malfunction of Automatic Transmission

Some transmission malfunctions will cause the engine emission malfunction warning lamp to illuminate. To

protect the transmission, the system may cut off engine power to the clutch and the vehicle cannot be driven. Seek an MG Authorised Repairer immediately.

### Malfunction of Electronic Shift System

When some malfunctions of electronic shift system occur, the information centre indicates "Backup for E-shifter is Activated. Consult Handbook". At this time, the gears can still be shifted normally.

When some severe functional malfunctions of electronic shift system occur, the P button indicator on the electronic shift lever flashes and the information centre indicates "EP". At this time, the gears can not be shifted. For driving safety, when the vehicle speed is lower than a certain value, the power system will forcibly cut off the power transmission, and the vehicle will not be able to drive!

In case of the above situations, seek an MG Authorised Repairer immediately.

### Driving Mode \*



**Switching the driving mode when the vehicle is in motion can divert driver's attention from road conditions, this operation can only be performed when safety permits.**

The vehicle is equipped with a Driving Mode switch in the centre console, operating this switch allows the driver to select their preferred driving mode.

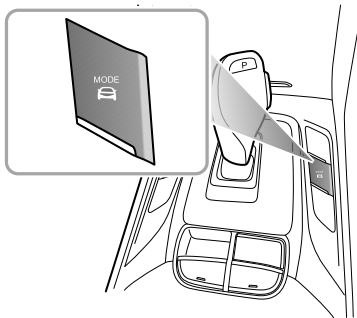

When the vehicle is in motion or stationary, pressing the driving mode selection switch (MODE) once will cycle through the available driving modes:

#### 1 ECO Mode

The vehicle is placed in a "low energy" usage state and will provide optimum fuel consumption and emissions.

#### 2 NORMAL Mode

The vehicle enters balanced tuning state for daily driving.

#### 3 SPORT Mode

Provides the driver with a more dynamic driving experience, suitable for sporty driving style.

#### 4 CUSTOM Mode \*

After selecting CUSTOM mode, the driver can personalize some systems using the infotainment display when the vehicle is stationary.

When the start/stop switch is switched off all CUSTOM settings are saved.

## STARTING & DRIVING

**Note:** When the electronic shift lever is in *D/S* position, pull it backward to enter or exit *SPORT* mode.

### SUPER SPORT Mode

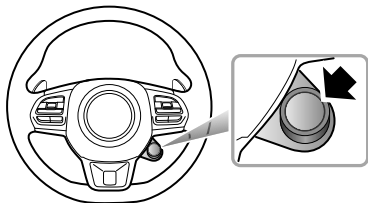

Pressing the SUPER SPORT button on the steering wheel can instantly enter or exit SUPER SPORT mode.

Whilst in SUPER SPORT mode, there is a change to ambient lighting for some models, which is suitable for intense driving.

**Note:** The entry/exit of this mode can only be achieved by using the SUPER SPORT button, after exiting Super Sport, the vehicle will return to the previous selected driving mode.

When switching the driving mode, the instrument cluster will display a corresponding message (ECO, NORMAL, SPORT, CUSTOM \* and SUPER SPORT).

When the start/stop switch is switched off, the vehicle will switch back to NORMAL mode by default.

In different driving modes, the power delivery, steering and air conditioning system varies, please refer to the table below.

Mode	Powertrain	EPS	HVAC
<b>ECO</b>	Eco	Comfort	Eco
<b>NORMAL</b>	Normal	Normal	Normal
<b>SPORT</b>	Sport	Sport	Normal

Mode	Powertrain	EPS	HVAC
<b>SUPER SPORT</b>	Sport	Sport	Normal
<b>CUSTOM *</b>	Custom	Custom	Custom

## Ambient Lighting \*

Ambient lighting can be linked with the driving mode, it will switch between different colours in different driving modes. When the ambient lighting is in the CUSTOM state, it will not be affected by the driving mode. For the setting of ambient lighting, please refer to the infotainment display.

## Powertrain System

The transmission changes the shift pattern according to the set driving mode. When the powertrain is in ECO, NORMAL and SPORT mode, the instrument cluster will display "E", "D" and "S" respectively.

**Note:** *If the powertrain system develops a fault or suffers a failure, it will enter NORMAL mode automatically.*

## Steering System

The steering system appropriately increases or decreases the assist output according to the set driving mode. The driver effort to turn the steering wheel will be altered according to the set mode. For the conditions for switching the steering feel, please refer to "Steering System" in "Instruments and Controls" chapter.

**Note:** *If the electronic steering system develops a fault or suffers a failure, it will enter NORMAL mode automatically.*

## Air Conditioning System

Whilst in ECO mode, if the air conditioning system is switched on it will operate in an energy saving mode. This reduces power consumption and allows more power to be directed to the vehicle.

# STARTING & DRIVING

---

## Brake System

### Foot Brake

For added safety, the hydraulic braking system operates through dual circuits. If one circuit should fail, the other will continue to function, but greater pedal pressure will be needed, the brake pedal travel will be increased, and the stopping distances will be increased. In the event of a brake failure where only one circuit is operational, the car should be brought to a halt as soon as traffic conditions safely allow. DO NOT continue driving - seek an MG Authorised Repairer.

### Servo Assistance

The braking system is servo assisted, always be aware of the followings during the operation:

- The servo assistance functions with the engine running only. Never allow the car to freewheel with the engine turned off.
- If the engine should stop for any reason while driving, bring the car to a halt as quickly as traffic conditions safely allow, and do not pump the brake pedal as the

braking system will lose any remaining servo assistance. Once the engine has stopped, it will lose any remaining servo assistance, use suitable force to apply the brake pedal to stop the car safely in the current traffic conditions. Contact an MG Authorised Repairer.

- The efficiency of the brake servo booster can be affected by numerous conditions, such as the change of barometric pressure. These conditions could result in extra force required to operate the brake pedal to stop the car.

### Wet Conditions

Driving through water or heavy rain may adversely affect braking efficiency. The SCS (Stability Control System) includes a Brake Disc Wiping function which is activated when the windscreen wipers are used. However, always keep a safe distance from other vehicles and intermittently apply the brake pedal in conditions where the wipers are not used.

### Electronic Brake Force Distribution (EBD)

Your car is equipped with EBD, which, in order to maintain braking efficiency, distributes braking forces between front and rear wheels, under all load conditions.

EBD integrates a monitoring system. The monitoring system is linked to the brake system malfunction indicator lamp on the instrument pack. Refer to "Warning Lights and Indicators" in "Instruments and Controls" chapter.

If the indicator lamp illuminates while driving, or remains illuminated after the start/stop switch is turned on (ON/RUNNING position), it indicates there is a failure with the braking system, and EBD may be inoperative. In such a case, stop the car as soon as safety permits and seek an MG Authorised Repairer immediately. **DO NOT** drive the car with the brake system malfunction indicator lamp illuminated.

### Electronic Brake Assistance (EBA)

Your car is equipped with Electronic Brake Assist, which reacts to the speed at which the brake pedal is applied. If, in an emergency situation the brakes are applied faster than

the limits set within the system, then full ABS application is applied to bring the car to a stop in the shortest possible distance.

### Hill Hold Control (HHC)



***HHC has limitations when subject to adverse conditions such as wet or icy surfaces and steep slopes.***



***HHC is not a substitute for parking brake application when carrying out a hill start. DO NOT exit the vehicle with only HHC applied, it may lead to a serious accident when HHC releases.***



***The car may roll if 'pull-away' is not achieved immediately after releasing the brake pedal. Always ensure the brake pedal is pressed or parking brake applied until drive is taken up.***



***Always ensure the brake pedal is pressed or electronic parking brake applied until drive is taken up.***

## STARTING & DRIVING

---



**Firm application of the brake pedal when stopping is required by HHC to generate sufficient brake pressure to maintain hold.**

Hill Hold Control (HHC) is a comfort function. It works on inclines when the car detects it has come to a 'stand still status'. Once the clutch pedal has been pressed down (MT) or in D/R gear (AT) and the brake pedal released, the vehicle will maintain pressure in the braking system for 1 ~ 2 seconds. After this, the Hill Hold will release. HHC assists the driver by 'holding' the vehicle during hill starts.

The following conditions must be fulfilled to activate HHC:

- The driver's door is closed and the driver seat belt is fastened.
- The vehicle is stopped on a slope in excess of 4% and for more than 2 seconds.
- SCS is fault free.
- EPB is released and fault free.
- Clutch pedal is pressed (MT), or in D/R gear (AT).
- Engine is running.
- Sufficient brake pedal application force has been applied.

If the driver releases the brake pedal on a hill, HHC will maintain brake pressure for 1 ~ 2 seconds. If the vehicle fails to pull away in 1 ~ 2 seconds, the brake will automatically release, the vehicle may begin to roll. In this case, the brake pedal must be pressed immediately.

**Note: HHC is available in both forward and backward directions when pulling away on uphill slopes.**

**Note: If the information centre in the instrument pack displays the message "Hill Hold Unavailable", it indicates that the hill hold control is invalid or is not properly enabled, please seek an MG Authorised Repairer urgently.**

**Note: HHC cannot overcome physical limitations. DO NOT solely rely on HHC.**

### Auto Hold



**The auto hold function cannot guarantee the stability of the vehicle when starting off or braking on hills especially on slippery or icy surfaces.**





**When auto hold stops the vehicle for reasons such as engine cut out, releasing the seat belt or pressing the auto hold switch, the electronic parking brake is applied. It cannot be guaranteed that the vehicle will be stabilised in all cases. For example, the rear wheels are on a slippery road surface, or the vehicle incline is too great (larger than 20%). Please make sure that the vehicle is safely stabilised prior to exiting.**



**DO NOT take any extra risks when driving due to the fact the vehicle is fitted with additional convenience functions. The driver should pay full attention and observe the surroundings even if the vehicle is equipped with auto hold system.**



**DO NOT leave the vehicle when the engine is operating and the auto hold is active.**



**Auto hold cannot guarantee the electronic parking brake operation in all cases where the engine is stopped. Please ensure the electronic parking brake is applied and the vehicle is stabilised prior to exiting the vehicle.**



**The auto hold function should be switched off during the use of automatic car washes, the electronic parking brake may suddenly apply and cause damage to the vehicle.**

If the vehicle is required to stop frequently for a length of time (such as traffic lights, traffic queues or stop/start), and the engine is running, the auto hold system assists in stabilising the vehicle, enabling you to remove your foot from the brake pedal when the vehicle is stationary and the Auto Hold active.

Auto hold has 3 main states:

- 1 Off: Function in Off state.
- 2 Standby: Function in Standby state. The function is active but the vehicle has not stopped. Once the

## STARTING & DRIVING

vehicle has stopped, and all other conditions are met, the system will automatically select Park.

- 3 Parking: Function in Parked state. In this state the green (P) indicator in the instrument pack illuminates.

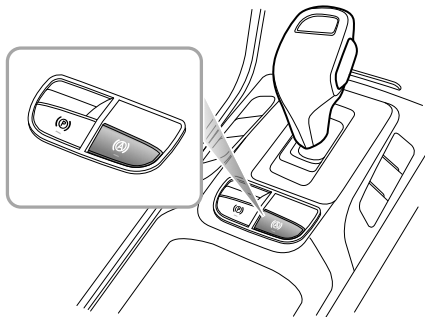

With the driver's seat belt fastened, the door closed and the engine running, press the auto hold switch to switch the auto hold function from Off to Standby state.

With the brake pedal firmly pressed and the vehicle completely stopped, the auto hold function will switch from the Standby state to the Parking state.

When the auto hold is in the Parking state, engaging forward or reverse gear and pressing the accelerator will automatically release the auto hold function.

In some circumstances such as releasing the seat belt, switching off the engine or remaining static for a length of time it will result in the vehicle exiting the auto hold Parking state. At this time the electronic parking brake will remain applied and will require the driver to release it using the switch.

**Note:** With the brake pressed, press the switch to switch off the auto hold function, but the electronic parking brake will not be applied.

**Note:** It is recommended to turn off the auto hold function when reversing into the garage.

**Note:** For MT models, press the accelerator pedal to start off.

### Hill Descent Control (HDC)



*The HDC system is only an auxiliary function. It has limitations when subject to adverse conditions such as wet or icy surfaces and steep slopes. The HDC system cannot overcome the laws of physics, always ensure that the vehicle is driven down steep slopes at low speeds.*



*Even when the HDC system is switched on, the driver must always pay close attention to the driving state of the vehicle, and take active control when necessary. In certain cases, HDC may be suspended or switched off temporarily.*



*During some driving conditions on downhill surfaces (e.g. driving down a slope with high speed, the slope is less than 10%, etc.), HDC is inoperative, the driver must maintain control of the vehicle at all times and use brake applications to ensure safety.*

The HDC system is an auxiliary function specially designed for driving on acute downhill gradients. The system reduces the speed by applying brake force, thus assisting the driver to drive on acute downhill surfaces with low speeds.

Please DO NOT use this function when driving on the ordinary roads.

When the HDC is working, the brake system may generate strong vibration or noise. It is normal during the operation of HDC.

**Note:** *During the operation of hill descent control (HDC) system, please do not switch the shift lever to "N" position. Such operation may deactivate the HDC function.*

## STARTING & DRIVING

### HDC System On/Off

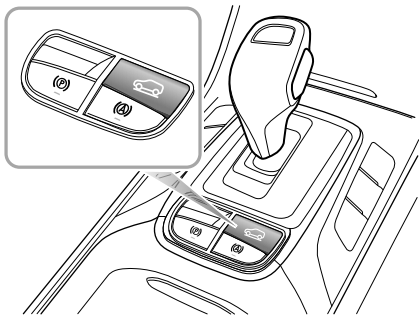

When the start/stop switch is placed in ON/RUNNING position, HDC system defaults to off. Press the button to turn on/off HDC system.

Normally, HDC system has four states as follows:

- 1 Standby: Press the HDC switch to set the system into standby mode, the green HDC warning lamp in the instrument pack will illuminate.

- 2 Operating: whilst in Standby mode, when the vehicle is driven down an acute gradient, if the accelerator and/or brake pedals are not pressed and if the vehicle speed is higher than 5mph (8km/h) but less than 22mph (35km/h), the HDC system will automatically enter the operating state. In this case, the HDC warning lamp in the instrument pack flashes green, this may be accompanied by the working noise of the brake system. The HDC system will attempt to maintain the vehicle at the current speed. After the driver presses the accelerator or brake pedal, and the vehicle speed is still within the range of 5 ~ 22mph (8 ~ 35km/h), the HDC system will control the target speed as the latest current speed.
- 3 Temporary Deactivation: press the accelerator or brake pedal beyond a preset limit whilst in operating mode and the HDC system will temporarily suspend operation.
- 4 Off: press the HDC switch (OFF) to switch the system OFF, the green HDC warning lamp in the instrument pack will extinguish.

**Note:** For MT models, HDC function can be applied only in 1st gear.

**Note:** When the vehicle turns at a fast speed whilst on an incline, the HDC system may switch from Standby to Operating mode.

**Note:** During HDC system operation the braking system will automatically pressurise and maintain pressure. Operation of the brake pedal during this phase may result in a 'kickback' sensation through the pedal. This is normal for HDC operation.

### HDC ON/Malfunction Indicator Lamp

Refer to "Warning Lights and Indicators" in "Instruments and Controls" chapter.

### Anti-lock Brake System (ABS)



**ABS cannot overcome the physical limitations of stopping the car in too short a distance, cornering at too high a speed, or the danger of aquaplaning, i.e. where a layer of water prevents adequate contact between the tyres and the road surface.**

The purpose of the ABS is to prevent the wheels from locking while braking, thereby enabling the driver to retain steering control of the car.

The fact that a car is fitted with ABS must never tempt the driver into taking risks that could affect his/her safety or that of other road users. In all cases, it remains the driver's responsibility to drive within normal safety margins, having due consideration for prevailing weather and traffic conditions.

Under normal braking conditions, ABS will not be activated. However, once the braking force exceeds the available adhesion between the tyres and the road surface, thereby causing the wheels to lock, ABS will automatically

## STARTING & DRIVING

---

come into operation. This will be recognisable by a rapid pulsation felt through the brake pedal.

### Braking in an Emergency



***DO NOT pump the brake pedal at any time; this will interrupt the operation of ABS and may increase the braking distance.***

If an emergency situation occurs, the driver should apply full braking effort even when the road surface is slippery. ABS will ensure that the wheels do not lock and that the car is brought to a halt in the shortest possible distance for the prevailing road surface conditions.

***Note: On soft surfaces such as powdery snow, sand or gravel, the braking distance produced by the ABS system may be greater than that for a non-ABS system, even improved steering would be experienced. This is because the natural action of locked wheels on soft surfaces is to build up a wedge of material in front of the tyre contact patch. This effect assists the car to stop.***

No matter how hard you brake, you are still able to continue steering the vehicle as normal.

#### IMPORTANT

ABS can not reliably make up for the driver's mis-operation or lack of experience.

### ABS Malfunction Indicator Lamp

Refer to "Warning Lights and Indicators" in "Instruments and Controls" chapter.

***Note: The normal (non-ABS) braking system remains fully operational and is not affected by partial or full loss of ABS. However, the braking distances may increase.***

### Active Rollover Protection (ARP)



***The ARP system cannot overcome the laws of physics. It is a driver aid to assist the stability of the vehicle and under extreme conditions. It is not a guarantee that the car will not roll over.***

In cases where the vehicle has a high centre of mass, rapid or excessive dual direction lane changing may create a roll condition. ARP may use the braking system to apply certain brakes to try and correct the condition and assist in preventing rollover.

**Note:** *During ARP application the steering characteristics of the vehicle may be noticeably different from normal.*

### Emergency Braking Hazard Warning Lights Control System (HAZ)

If the vehicle is travelling at high speed and the driver makes an emergency braking manoeuvre, the system will automatically flash the brake lamps to remind the following drivers, thereby effectively reducing the risk of rear-end collision accidents.

**Note:** *If the hazard warning lights are being operated manually, this suspends the HAZ function.*

When the emergency braking manoeuvre is exited (no severe deceleration detected) then the function will be switched off after a few seconds.

**Note:** *As the car speed drops to below 6mph (10km/h) and the system no longer flashes the brake lamps, the hazard warning lamps will illuminate automatically. Short press the hazard warning lamp switch or increase your speed to above 12mph (20km/h) for 5s to switch off the hazard warning lamps.*

## STARTING & DRIVING

### Electronic Parking Brake (EPB)



*In the event of EPB malfunction where EPB release is not possible, please consult an MG Authorised Repairer in order to carry out an emergency manual release of the parking brake.*

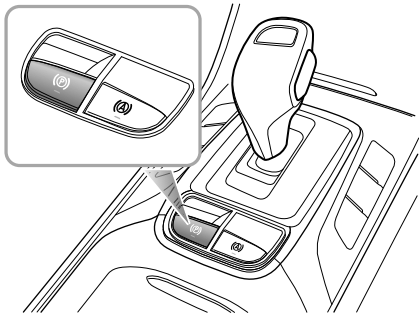

### Applying the EPB

While the vehicle is stationary, the EPB can be applied. Ensure the EPB is applied every time the vehicle is left or parked.

- Pull the EPB switch upward until the indicator in the EPB switch illuminates.
- Simultaneously, the EPB indicator (P) will illuminate in the instrument pack. When the indicator in the EPB switch and the EPB indicator are illuminated, it indicates that the EPB is applied.
- If the EPB malfunction indicator lamp (P with a diagonal slash) in the instrument pack remains on, it indicates that a fault has been detected. Please contact an MG Authorised Repairer immediately.

**Note:** *An audible motor noise may be heard when applying or releasing the EPB.*



### IMPORTANT

- In the event of a flat battery or power failure, it is not possible to apply or release the EPB. In such a case, 'jump leads' shall be used for emergency engine start, please refer to "Emergency Starting" in "Emergency Information" chapter.

### Releasing the EPB

- Switch on the vehicle, press the brake pedal, and press the EPB switch.
- If the indicator in the EPB switch and the indicator in the instrument pack (Ⓢ) are extinguished, the EPB is released.

### Start Assist

The EPB can predict the driver's intention and automatically release the EPB.

If the driver's seat belt is fastened, the engine is running, D or R gear is selected and the accelerator pedal is depressed in order to pull away; or when the clutch pedal is fully pressed, forward or reverse gear selected and the

clutch pedal lifted whilst pressing the accelerator, the EPB will automatically release.

### Emergency Braking Function



***Inappropriate use of the EPB can lead to accidents and injuries. Do not apply the EPB for vehicle braking, unless in emergency.***



***During emergency braking using the EPB, DO NOT switch off the vehicle, this could result in serious injury.***

In the event of normal brake failure, emergency braking using the EPB can be initiated by pulling and holding the EPB switch upward.

- If the SCS can respond actively to the request from the EPB, the SCS will activate and apply all 4 brakes. If the SCS is unable to respond to the request from the EPB, then the EPB will only activate the rear brakes.
- During emergency braking using EPB, a continual audible warning will sound. To cancel the emergency braking process, release the EPB switch.

# STARTING & DRIVING

---

## Stability Control System (SCS) and Traction Control System (TCS)

### Stability Control System (SCS)

SCS is designed to assist the driver in control of driving direction. The SCS automatically enters Standby mode after the engine is started.

When SCS detects that the vehicle is not moving in the intended direction, it will intervene by applying brake force to selected wheels or through the engine management system to prevent sliding and assist in bringing the car back to the right direction.

### Traction Control System (TCS)

The purpose of TCS is to aid traction, thereby helping the driver to maintain control of the car in situations where one or both of the driving wheels are spinning (for example, if one wheel is on ice and the other on tarmac). TCS monitors the driving speed of each wheel individually. If spin is detected on one wheel, the system automatically brakes that wheel, transferring torque to the opposite, non-spinning wheel. If both wheels are spinning,

the system will reduce engine speed in order to regulate wheel rotation until traction is regained.

### Switching On/Off

SCS and TCS are automatically switched to standby when the START/STOP Switch placed in the ON/RUNNING position. They can be switched off by using the "Stability Control" switch located within the infotainment system display.

When SCS and TCS are switched off, the Stability Control/Traction Control System OFF warning lamp will illuminate - refer to the "Warning Lights and Indicators" section in the "Instruments and Controls" chapter.

**Note:** *Disabling SCS and TCS will not affect the operation of ABS. Always disable SCS and TCS when driving with snow chains fitted.*

### Stability Control/Traction Control Warning Lamps

Refer to "Warning Lights and Indicators" in "Instruments and Controls" chapter.

If the battery has been disconnected, upon reconnecting the warning lamp will illuminate yellow. Please complete the following steps.

- EPS initialization, refer to "Steering System" in "Instruments and Controls".
- Switch the vehicle off and restart.
- Drive the vehicle over 12mph (20km/h), turning the steering wheel left for 45°, then right for 45°. The warning lamp will extinguish.

## STARTING & DRIVING

---

### Tyre Pressure Monitoring System (TPMS)



*TPMS can not replace routine maintenance and checks of the tyre condition and pressure.*



*If the radio transmission equipment (such as interphone, wireless headphones, etc.) is used inside or near the car, the operation of TPMS system may be interfered, leading to temporary failure alarm.*

**Note:** *TPMS only warns of low tyre pressures, it does not re-inflate the tyre.*

TPMS uses pressure sensors built into tyre valves to continuously monitor pressure and transmits signal to ECU inside the vehicle using RF signals. If it deduces that the pressure of that tyre has fallen below the predefined limit of the system, the warning light on the instrument pack will illuminate (always yellow). For more information, please refer to 'Instrument Pack' in 'Instruments and Controls' section. Check your tyres at the earliest opportunity and

reinflate to the correct pressure. Please refer to 'Tyre Pressure (Cold)' in 'Technical Data' section.



If the TPMS malfunction indicator lamp illuminates, and the warning message "XX Tyre Pressure Low" is displayed on some models it is advised that you please stop the car as soon as possible, check the tyre pressure and inflate the tyre to correct pressure value. Over or under-inflated tyres wear out more rapidly and also have a detrimental effect on the car's handling characteristics. Under-inflated tyres increase the rolling resistance of the car which, in turn, increases fuel consumption. Always check/adjust tyre pressures when they are cold.

#### TPMS Self-learning

When replacing a TPMS sensor and receiver, or performing tyre rotation, the TPMS self-learning is required, please consult a local MG Authorised Repairer for details.

### STOP-START Intelligent Fuel Saving System

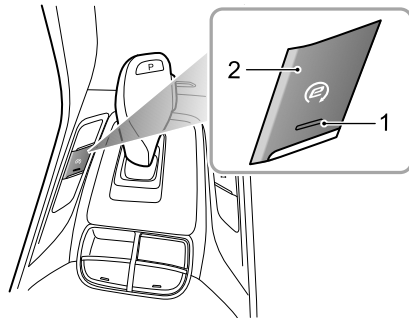
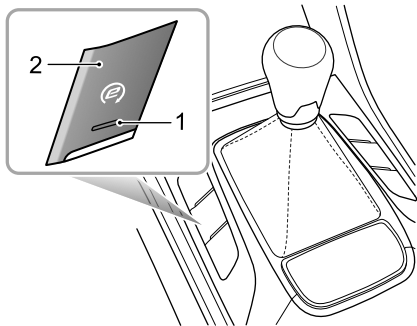

- 1 Main Switch Lamp
- 2 Main Switch

## STARTING & DRIVING

---

Engine Stop-Start has been incorporated into vehicles in an effort to reduce fuel consumption. As the name suggests the system will allow the engine to be switched off when engine power is not required and then automatically be restarted when it is.

This system defaults “on” with the START/STOP switch in the ON position, the switch indication light is on (1 in the fig) and can be turned off by pressing the main switch (2 in the fig). The lamp in the switch will extinguish.

**Note:** *If vehicle is driving through deep water, please use Stop-Start intelligent fuel saving system main switch (2 in the fig) to shut down Stop-Start intelligent fuel saving system.*

### Automatic Shutdown of Engine



***Although the engine is not running after an automatic stop, the system is still operating, therefore the following actions could be dangerous:***

***Leaving the vehicle while the seat belt is still buckled, or there is a substitute seat belt buckle inserted.***

***Vehicles with automatic transmission: The driver leaves the vehicle, with the shift lever still in Drive position (R/D/S).***

***Carrying out work or checks in the engine compartment.***

***Refuelling the vehicle, the START/STOP switch must be switched “OFF” or the key removed from the switch.***

Under the condition where the Stop-Start intelligent fuel saving system is enabled, the engine will be automatically shut down when detecting the following actions carried out by the driver as well as the vehicle status after the vehicle

is stopped, and the Stop-Start fuel saving system indicator lamp in the instrument pack  illuminates:

- Gearbox must be in neutral and clutch pedal is released (manual). Transmission in Drive with footbrake pressed (automatic).
- Vehicle is stationary, i.e. speed =0 mph (0km/h), and the maximum vehicle speed before stopping exceeded 6mph (10km/h).
- There is no significant steering operation after the speed drops below 6mph (10km/h).
- The bonnet and the driver's door are closed and seat belt is secured.

The Stop-Start intelligent fuel saving system will be disabled and the engine will not be stopped automatically when the followings occur:

- Coolant temperature is below a preset limit.
- Adaptive cruise control system is on.
- Front defrost is on.
- The A/C determines that the temperature inside the vehicle does not meet the target value.
- Low battery or battery temperature not within the desired range.

- The vacuum in the braking system falls below a preset limit.
- Starter motor temperature is above a preset limit.
- Reverse gear selected or has been selected prior to parking.
- In high-altitude zones.
- On the hill.

### Automatic Engine Start

After the car is stopped, the engine will be automatically started when detecting one of the following driver actions, the Start-Stop system indicator lamp on the instrument pack  extinguishes:

- Vehicles with automatic transmission: Release the brake pedal with gear in D position; Depress the brake/accelerator pedal with gear in P/N position; Shift the lever to R/D/S position.
- Vehicles with manual transmission: Depress the clutch/accelerator pedal with Neutral selected.

**Note: When the EPB system or Auto Hold system is enabled, the engine will not automatically restart.**

## STARTING & DRIVING

---

**Note:** *In some individual situations, the malfunction indicator lamp in the instrument will illuminate in the process of automatic engine start. This occurs due to the low voltage during startup, not indicating actual faults. If the malfunction indicator lamp remains on after engine start-up, seek a local MG Authorised Repairer.*

With the engine stopped in the automatic Stop-Start condition, the following actions will cause an automatic restart:

- Front defrost selected.
- Adaptive cruise control system is on.
- Activation of the air conditioner, and the temperature inside the vehicle does not meet the target value.
- Battery power falls below a preset limit.
- The vehicle begins to move.
- The vacuum in the braking system falls below a preset limit.
- The Start-Stop main switch (2) is pressed.

If any of the following occur after the engine is automatically stopped, the engine can only be manually started, at

this time, the Start-Stop system indicator lamp on the instrument pack  extinguishes:

- The driver side seat belt is unbuckled.
- The driver's door is opened
- The bonnet is opened

**Note:** *Extremely low battery power may result in the engine not re-starting automatically, or even using the key. In this instance, external power is needed to start the engine or the battery will require re-charging. See the section 'Emergency Starting' in the 'Emergency Information' Chapter.*

### Battery



**When charging/discharging the battery, starting the car with an external power source or supplying power from the vehicle, the negative cable must be connected to vehicle body earth point, rather than the battery negative. Failure to do this will result in inaccurate battery power calculation which will effect the automatic engine start.**





**DO NOT disconnect the battery sensor unless absolutely necessary. Removal will result in inaccurate battery power calculation which will effect the automatic engine start.**

Failure to operate within the following guidelines will effect battery performance and automatic Start-Stop control:

- 1 After power interruptions (battery disconnection) the automatic Start-Stop function will be suspended until the vehicle is left in a locked state for at least 4 hours whilst the system relearns the state of the battery.
- 2 If the vehicle is run continually for more than 100 hours uninterrupted, the Start-Stop function will be suspended until the vehicle is left in a locked state for at least 4 hours whilst the system relearns the state of the battery.
- 3 If the battery requires replacement, ALWAYS use a genuine part to the manufacturers specification. Failure to adhere to this can affect the automatic Start-Stop system.

### Stop-Start Intelligent Fuel Saving System Failure

In the event of a Stop-Start Intelligent Fuel Saving System failure, contact an MG Authorised Repairer. The Stop-Start Intelligent Fuel Saving System can be effected by faults within other vehicle systems - in the event of failure contact an Authorised MG Repairer.

### Starter Inoperative, Serious Battery Capacity Loss

In the case of serious battery power loss, automatic Stop-Start and key start may not be possible. In this case refer to the Emergency Information chapter, Emergency Starting section for further details.

**Note: DO NOT connect the jump battery negative cable to the battery negative! It will result in inaccurate battery power calculation which will effect the automatic engine start.**

# STARTING & DRIVING

## Cruise Control System \*

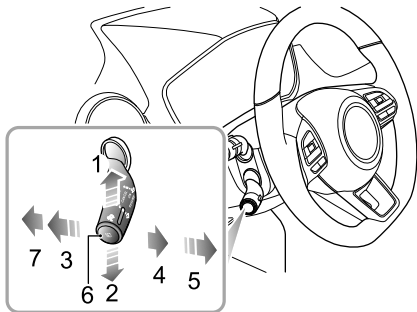

- Acceleration (1)
- Deceleration (2)
- Cancel (3)
- ON (4)
- Resume (5)
- Set (6)
- OFF (7)

Cruise control enables the driver to maintain a constant road speed without using the accelerator pedal. This is particularly useful for motorway cruising, or for any

journey where a constant speed can be maintained for a lengthy period.

### Cruise Control System Activation

Cruise control system is operated with a lever located at the left side of the steering wheel underneath the lighting stalk switch.

- 1 With the START/STOP switch in the ON/RUNING position, if the cruise lever switch is in 'OFF' position (7), then the cruise control is in switched OFF . If the cruise lever switch is in 'ON' position (4), then the system is in Standby mode. Switch the cruise lever to 'ON' position (4), the yellow cruise indicator  on the instrument pack will illuminate and the cruise control system is in Standby mode.
- 2 When the cruise control system is in Standby mode, and the current speed exceeds 25mph (40km/h), press the 'Set' button (6) at the end of cruise lever, the yellow indicator on the instrument will change to green, and the cruise control system enters into activation mode, the operating speed range of cruise control system is 25mph - 125mph (40km/h - 200

km/h). The target speed of the cruise system will be set at the current speed, and the cruise system will take effect. At this time, the cruise control system will maintain the set speed without pressing the accelerator pedal. With vehicles fitted with manual transmission it is recommended that cruise control should only be used in 3<sup>rd</sup> gear and above.

**Note:** *The set speed held in the cruise control memory will be canceled when either the cruise control lever is switched to 'OFF' position (7) or the START/STOP switch turned off.*

### Target Cruise Speed Adjustment

When the cruise control is active, the 'target speed' can be increased or decreased:

Push the lever upwards (1) and hold, then release the lever switch when the desired speed is reached, this will increase the speed.

Push the lever downwards (2) and hold, then release the lever switch when the desired speed is reached, this will decrease the speed.

Push the lever switch upwards or downwards briefly to increase/decrease the vehicle target speed in increments of 1mph (1 km/h), then the vehicle will accelerate/decelerate to the new target speed.

Pressing the accelerator at any time will override the cruise control and allow acceleration to undertake manoeuvres such as overtaking. Releasing the accelerator will return the vehicle to the set target speed.

### Pause/Stand By

When the cruise control system is activated, the following operations will set the system to Standby mode:

- Lever switch moved to 'Cancel' position (3).
- Brake or clutch pedal pressed.
- The poor road condition brings the stability control system (SCS) into operation. For safety reasons, the cruise control system will automatically exit to Standby mode.
- An incline causes excessive decline in speed, the cruise control system shall automatically exit to Standby mode.
- Electronic parking brake (EPB) is operated.

## STARTING & DRIVING

---

### Resume

If the cruise control remains on after the disengagement, moving the lever switch to 'Resume' (5) will reinstate the target speed to the setting prior to disengagement.

#### Note:

- *Never use the cruise control system in the reverse gear.*
  - *Do not use the cruise control in unsuitable conditions, such as on slippery surfaces, excessively heavy rain or in traffic conditions that do not suit maintenance of constant speeds.*
  - *When not in use, ensure the lever switch is in 'OFF' position (7).*
  - *When the automatic transmission is in 'Sport' mode, it is not recommended to use the cruise control system.*
  - *During the operation of cruise control system, the actual speed may deviate from the target speed to some extent due to control precision or road conditions.*
- *If the actual speed is excessively lower than the target speed or SCS is activated due to the hill or road surfaces, the cruise control system may automatically revert to Standby mode.*
  - *Do not operate the switch for excessively long periods, or press multiple switches simultaneously, this may cause the system to fail. If this situation occurs, when it is safe to do so, cycle the START/STOP switch.*

### Adaptive Cruise Control System \*

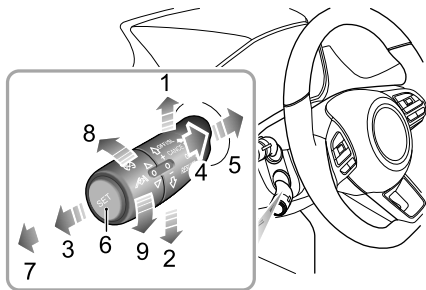

- Speed Limit Increase /Accelerate (1)
- Speed Limit Decrease /Decelerate (2)
- Cancel (3)
- On/Standby (4)
- Resume (5)
- Set (6)
- OFF (7)
- Increase the Distance (8)
- Reduce the Distance (9)



*The Adaptive Cruise Control (ACC) system is designed as a comfort system enabling the driver to maintain a constant speed or distance from the car in front. It provides assistance to the driver, it DOES NOT replace any of the drivers responsibilities. When using the ACC it is important that the driver maintains concentration at ALL times.*



*During the operation of the Adaptive Cruise Control System (ACC) the autonomous braking of the vehicle is limited. Therefore it is ESSENTIAL that the driver maintains concentration, observes the local laws, road and traffic conditions, and if at any time feels there is a danger to themselves or surroundings they should apply the brakes and disconnect the ACC.*

The ACC system can automatically switch between constant speed cruise and car following cruise control depending on whether it can detect a vehicle directly ahead. Constant speed cruise control is permitted between

## STARTING & DRIVING

---

20mph - 90mph (30km/h–150km/h) or car following cruise control by setting the distance between the vehicle and the vehicles directly ahead.



When activated if the ACC system detects a car in the same lane directly ahead it may accelerate or gently apply the brakes of the car to maintain the set following distance.

**Note: The Adaptive Cruise Control System (ACC) is designed for motorway cruising or any other journey where a constant speed or distance between your car and the vehicle in front can be maintained for a lengthy period.**

### Adaptive Cruise Control System Activation

The Adaptive Cruise Control system is operated with a lever switch located, at the left side of the steering wheel underneath the indicator/lighting stalk switch.

- 1 With the vehicle START/STOP switch in the ON position, if the adaptive cruise lever switch is in the 'OFF' position (7), then the adaptive cruise control system is switched OFF.

- 2 Move the adaptive cruise lever switch to the 'ON' position (4), the adaptive cruise system status indicator on the instrument pack  illuminates yellow, and the adaptive cruise control system is in the Standby mode.
- 3 The system will automatically detect the speed and position of the vehicle ahead, if your vehicle speed is above 3 mph (5km/h), after pressing the 'Set' button (6) at the end of the adaptive cruise stalk lever, the indicator on the instrument pack  will turn green, and the adaptive cruise control system enters the Activated mode, its target speed is the actual speed at activation; if your vehicle speed is less than 20mph (30km/h), then the target speed of the system is set at 20mph (30km/h). If the speed of the vehicle ahead is greater than the cruise target speed of your vehicle, your vehicle will maintain the target speed to conduct constant speed cruise; if the speed of the vehicle ahead is lower than the cruise target speed of your vehicle, it will enter the car-following cruise, an image of your car and the car ahead separated by a grid is displayed in the instrument pack message centre, in this mode the actual speed may be less than the set target

speed. Whilst in the car following cruise mode, you can follow the vehicle ahead to a stop, if the amount of time that the vehicle is in a stopped condition is less than approximately 3 seconds your vehicle may automatically pull away to follow the vehicle ahead, if the stopped time exceeds 3 seconds your car will not automatically pull away, you will receive a prompt in the instrument pack message centre requesting you to re-activate the adaptive cruise control using the method displayed.



***After following the vehicle ahead to a stop, the driver must observe any local traffic laws and ensure that there are no obstacles or other traffic participants, such as pedestrians, directly in front of the vehicle before allowing it to pull away and begin to follow the vehicle ahead again.***



***Whilst using the car following cruise function it is strongly recommended that the driver does not touch the accelerator pedal. Any activation of the accelerator will not allow the system to automatically apply the brakes should this be necessary.***



***DO NOT exit the vehicle when the ACC car following cruise function has stopped, or is keeping the car stationary. Before exiting the car the shift control lever should be in the Park position, the parking brake applied and the power switch in the OFF position.***



***If the ACC system has already stopped the vehicle, and the ACC function is disabled, turned off or cancelled, the vehicle will no longer stay still, it may move forward or slip backward. When the vehicle is stopped and kept still by the ACC system, be sure to be ready to apply the brakes manually.***

## STARTING & DRIVING

---

- 4 If the vehicle speed exceeds the maximum function speed of the ACC 90mph (150km/h) the system will automatically switch to the Standby mode, this means that all acceleration and braking manoeuvres must be carried out by the driver according to local traffic laws and traffic and road conditions.
- 5 If the adaptive cruise control system is already in use, the driver should pay special attention in the following conditions, select the appropriate speed, and be ready to take action or apply brakes.

### IMPORTANT

When an image of your car and rear end of the vehicle ahead separated by a grid, is displayed in the instrument pack message centre the ACC system will make any necessary response to the vehicle ahead, if the image is not displayed the ACC system will NOT make any response, the responsibility for any manoeuvres rest with the driver.

- Encounters a vehicle or object which is stationary or traversing the lanes.

- Approaching the vehicle ahead too fast, the adaptive cruise control system cannot apply sufficient braking force.
- A vehicle suddenly cuts into the lane in front.
- The vehicle ahead makes an emergency braking manoeuvre.
- An oncoming vehicle crosses the centre of the road and is driving towards you in the same lane.
- Encounters a vehicle driving at a low speed.
- Encounters a vehicle with loaded items protruding from the body side, rear or roof of the vehicle.
- Encounters a vehicle with a higher chassis (e.g., a truck).
- Encounters pedestrians, non-motor vehicles or animals.
- The vehicle is driving on a steep slope, an uneven road or a complex traffic road section.
- The vehicle makes a sharp turn.
- Water or snow splashed by surrounding vehicles hinders camera or radar detection.



- Excessive weight being carried in the boot space or cargo area causing the front of the car to point upwards.
- A fault exists in the system.

**Note:** *Manual deactivation of either the Traction Control System (TCS) or Stability Control System (SCS) will inhibit the operation of the Adaptive Cruise Control (ACC).*

### Adaptive Cruise Target Speed Adjustment

In order to set the target speed, the adaptive cruise control system must be in an active mode.

Use the accelerator pedal to reach the desired speed, short press the 'Set' button (6) on the end of the adaptive cruise switch lever, release the control button and accelerator pedal. The vehicle will cruise at the desired speed.

Move the lever switch upward (1) and hold, the target speed will increase until the desired set speed appears in the instrument pack, then release the switch. When it is confirmed that there is no vehicle in front of your vehicle

or the vehicle ahead exceeds the preselected following distance, the speed will be increased to the set speed.

Move the lever switch downward (2) and hold, the target speed will decrease until the desired set speed appears in the instrument pack, then release the switch. When it is determined that the vehicle ahead driving slowly is within the pre-selected following distance, the vehicle speed will decrease and keep the selected following distance.

**Note:** *Briefly operate the adaptive cruise lever switch upward (1) or downward (2) once, the target speed will change 5mph (5km/h), press and hold the lever upward or downward and the speed will increase or decrease in 1mph (1km/h) increments, release the lever when the desired speed reading is displayed.*

**Note:** *If the vehicle ahead continually makes hard acceleration or deceleration manoeuvres the adaptive cruise control may not be able accurately maintain the required distance between vehicles. It is important that the driver always concentrates and pay attention to the current vehicle position and situation in case they need to make a braking or avoidance manoeuvre.*

## STARTING & DRIVING

---

### Adaptive Cruise Target Following Distance Adjustment

When the adaptive cruise control system is activated, rotate the switch on the end of the lever upward (8) or downward (9) to adjust the following distance, you are able to toggle between 3 distance settings, the current following distance setting will be stored by the system until it is changed, and displayed in the message centre in the instrument pack.

Always select an appropriate following distance that is relative to the current speed of your vehicle and the vehicle you are following, the greater the speed, the further the distance. ALWAYS consider current traffic, road and weather conditions when making your selection.

### Adaptive Cruise Pause

When the adaptive cruise control system is activated, move the lever switch to the 'Cancel' position (3), and the system will exit to the Standby mode.

### Automatic Deactivation of Adaptive Cruise

In the following situations, the ACC may be automatically deactivated, this transfers full control of the vehicle to the driver.

- Move the lever switch to 'Off' position (7).
- Press the brake pedal whilst the vehicle is in motion.
- Move the shift lever away from the D position.
- The driver unfastens his/her seat belt.
- Press and hold the accelerator pedal beyond a preset time period.
- Open any door, bonnet or tailgate.
- Pull the EPB switch up to apply the parking brake.
- Follow the vehicle ahead to a stop and the stop time exceeds 3 mins.
- The sensor or radar view is blocked, the ambient light condition triggers the preset safe exit mechanism of the light sensor, or the system fails.

**Note:** *If following the vehicle ahead to a stop with the adaptive cruise control system enabled, if any of the following conditions occur whilst the vehicle is in a stopped state, the EPB will automatically be applied:*

- *The driver unfastens his/her seat belt.*
- *The driver door is opened.*
- *The stop time exceeds 3 mins.*

### **Adaptive Cruise Override**

If the driver has cause to use the accelerator pedal when the ACC is activated, the vehicle will remain in Cruise mode while the vehicle speed increases. When the accelerator pedal is released, the ACC will resume to operate at previously set cruise speed.

If the driver accelerates to a higher speed and then releases the accelerator the ACC will decrease to the target cruise speed in a more gradual manner. If it is necessary to decrease to the target cruise speed rapidly, the driver may manually move the lever switch 'Deceleration' (2).

**Note:** *If the accelerator pedal is pressed and held above the preset time period the ACC may exit to the Standby mode.*

### **Adaptive Cruise Resume**

If the ACC system has reverted to, or been switched to, the Standby mode it can be reactivated by moving the lever switch to 'Resume' position (5). The target cruise speed will automatically be set to the target speed before exiting the adaptive cruise control system.

When driving at a high speed, if the driver resumes to a lower target cruise speed, the ACC will decrease to the target cruise speed in a more gradual manner. If it is necessary to decrease to the target cruise speed rapidly, the driver may manually move the lever switch 'Deceleration' (2).

### **Clear the Speed Memory**

If the lever switch is moved to 'OFF' position (7) or the vehicle START/STOP switch is switched to the OFF position, the system may clear the adaptive cruise control set speed in the memory.

# STARTING & DRIVING

## Special Driving Environments

The Adaptive Cruise Control (ACC) system has its limitations. Listed below are some conditions that may be beyond the safe operating limits. The driver should maintain control of the vehicle and must remain alert at all times. They should pay special attention to the traffic conditions and surroundings, select the appropriate speed and be ready to take any required actions.

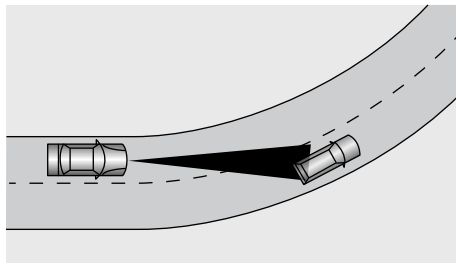
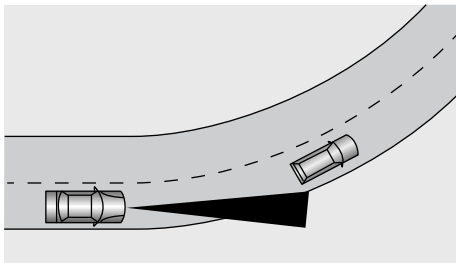

When turning at an intersection or following a vehicle into, or out of a curve, the ACC system may be unable to detect the vehicle ahead, even if it is in the same lane, it is possible the system may detect a vehicle in another lane.

**Note: Do not use the adaptive cruise control system on entrance/exit ramps or sharp bends.**

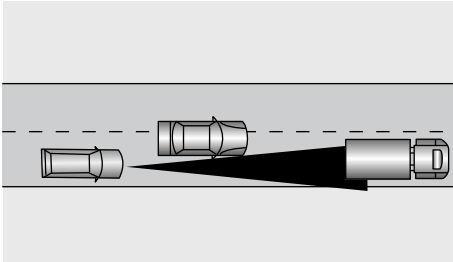

If the vehicle ahead changes lanes, but does not drive into the lane completely, the ACC system may be unable to detect the vehicle.

If the vehicle ahead changes lanes, but does not exit the lane completely, the adaptive cruise control system may determine that the vehicle ahead has exited the lane and accelerate to any preset speed.

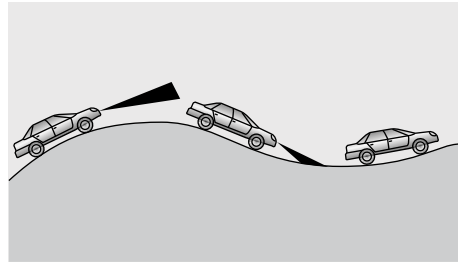

When driving on uneven roads that may include steep climbs or dips please **DO NOT** use the ACC system.

## STARTING & DRIVING

---

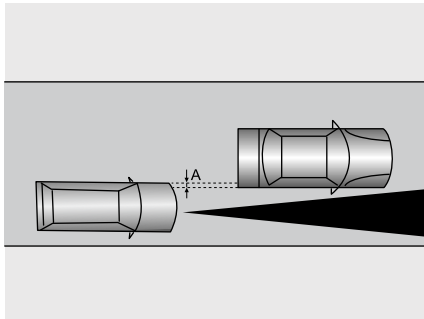

When driving behind a vehicle that is only partially overlapping your vehicle, 'A' in the graphic, the ACC system may be unable to detect anything.

**Note: Please DO NOT use the adaptive cruise control system in the following situations:**

- *The ambient light level is insufficiently low, extremely bright, or the forward lighting of the vehicle is poor or compromised.*

- *The front view camera in the windscreen and/or radar sensor in the front bumper have a restricted field of vision, or severe weather such as heavy fog, heavy rain, heavy snow, ice, etc are affecting the sensor's field of view.*
- *In conditions where the demist function of the windscreen is impaired.*
- *When driving the vehicle on a low-friction road (rapid changes in tyre traction may result in excessive wheel slip).*
- *When driving on a strong reflective road surface as a result of rain, snow, or ice.*
- *When the radar may be affected by electromagnetic interference (for example, metal objects such as rails and metal plates for road construction).*
- *After the position of radar has changed (for example, collision, vibration).*
- *Radar signals could be incorrectly reflected by local conditions (e.g., in multi-storey car parks, tunnels, water jets from sprinklers, etc.) these may degrade the function of the radar sensor.*

### Parking Aid System \*

#### Ultrasonic Sensor Parking Aid \*



*The purpose of the parking aid is to assist the driver in reversing! The sensors may not be able to detect obstacles of certain type, e.g. narrow posts or small objects no more than a few inches wide, small objects close to the ground, objects above the tailgate and some objects with non-reflective surfaces.*



*Keep the sensors free from dirt, ice and snow. If deposits build up on the surface of the sensors, their performance may be impaired. When washing the car, avoid aiming high pressure water jets directly at the sensors from close range.*

#### Rear Parking Aid

The ultrasonic sensors in the rear bumper monitor the area behind the vehicle to search for obstacles. If any obstacle is detected, the system will calculate its distance from the

rear of the vehicle and communicates the message to the driver by sounding warning chimes.

#### Parking Aid in Operation

When the START/STOP Switch is in the ON/RUNNING position, the rear parking aid is enabled automatically when reverse gear is selected, it is switched off as soon as reverse gear is disengaged. A short beep is given by the parking aid within 1 second after selecting reverse gear to indicate that the system is operating normally.

**Note:** *If a longer, higher pitched sound is emitted for 3 seconds when reverse gear is selected this indicates a fault in the system. In this case seek assistance from your MG Authorised Repairer.*

With the parking aid enabled, when obstacles are detected, the system will give sounds in different frequencies (there might be blind areas).

## STARTING & DRIVING

---

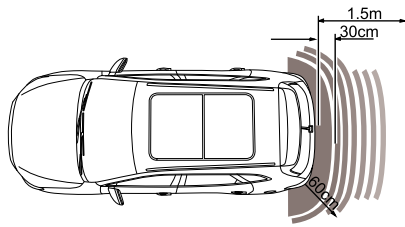

- If an obstacle is located within 1.5m range of the rear parking aid sensors or within 0.6m range of the corner sensor, the warning commences. As the car moves closer to the obstacle, the audible sounds are transmitted more rapidly.
- Once the obstacle is within 30cm range of the rear bumper, the audible sounds will merge into a continuous warning.

### Parking Camera \*



*The purpose of the parking camera system is to assist the driver during reversing! The camera has limited field of view and cannot detect obstructions outside the field of view.*

Some models have a rear parking camera fitted between the rear license plate lamps. When reverse gear is selected, the camera will display an image of what is immediately behind the car. This image will be shown on the infotainment system display.



### Rear Driver Assistance System

#### System Overview



*The rear driver assistance sensors may misidentify some surroundings, such as roadside buildings or guardrails and provide a false alarm.*



*The effective recognition capabilities of the rear sensors can be limited by objects such as roadside buildings, guardrails, changes in pitch angle of the car due to heavy loading, road conditions such as bends or bumps or weather conditions such as snow and ice etc. Any of the above may trigger a false alarm.*



*The rear driver assistance function is only an aide, it is NOT a substitute for the attention of the driver. The driver must always remain in control, observe the surroundings and drive safely.*



*The rear driver assist system may not provide adequate warning of very fast approaching vehicles or operate correctly on tight curves of radius.*



*The rear driver assist system will not operate correctly whilst towing a trailer or caravan.*



*The correct operation of the rear sensors will be compromised if they are misaligned due to accident damage. This may cause the system to automatically shutdown.*



*To ensure that the radar sensors work correctly, the rear bumper should be kept free of snow and ice and must not be covered.*



*Use of non recommended materials or paint on rear bumper repairs may have a detrimental effect on the operation of the rear sensors. Please only use recommended materials.*

## STARTING & DRIVING

---

The rear driver assistance system includes blind spot detection (BSD), lane change assist (LCA), rear cross traffic alert (RCTA) and door open warning (DOW) functions.

The rear driver assistance modules are mounted at the rear of the vehicle on each side, they can assist in detecting vehicles behind or to the side of your vehicle.

The warning lamps to support this system are located within the LH and RH door quarter light trims, they will illuminate or flash to warn of an approaching object or car to assist you in manoeuvring the car safely.

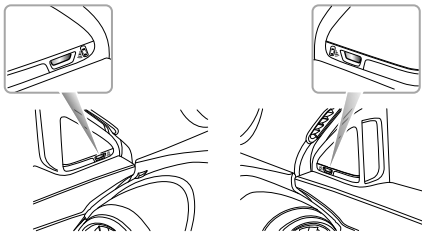

**Note:** *The radar requires calibration on new vehicles or for vehicles of where a rear detecting radar sensor has been replaced. The rear detection radar sensors possess an automatic calibration function to compensate for installation error within a certain range. When the vehicle is running, the radar will automatically enter the calibration state. During the calibration process, the system will provide limited functions, and the alarm may be inaccurate. Upon completion of the calibration, the system will resume all functions.*

### Switching the System Functions On/Off

The rear driver assist system function switches can be accessed via the infotainment screen.

Select: 'Vehicle Settings', 'Driving Assist' and 'Rear Driving Assist' (you may have to scroll left or right to access this option). Select ON/OFF to activate/deactivate the system. A warning message to alert you of your choice will be displayed in the message centre in the instrument pack.

If the 'Rear Driving Assist' is ON, the sub system menu will become 'live' and you can select the ON/OFF option

for each of the sub systems. If the 'Rear Driving Assist' is switched OFF, none of the sub systems will be selectable and the entire system will be in an OFF state.

When the vehicle is restarted, the system will keep the previously stored switch settings.

### **System Functions**

#### **Blind Spot Detection (BSD)**

When the vehicle is driving forward, the system will monitor for motor vehicles located in the blind zones of the left and right exterior mirrors. When the conditions for activating the blind spot detection function are met, the corresponding warning lamps will illuminate. Subsequent operation of the relevant indicator will cause the warning lamp to flash to remind the driver of an approaching vehicle.

## STARTING & DRIVING

---

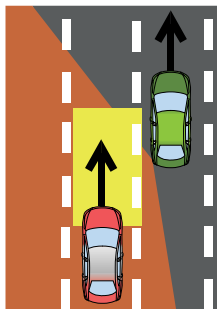

of the vehicle, the monitored areas are 2m ahead , 7m behind the rear of the vehicle, and 4.7m from the side of the vehicle.

**Note:** *The warning lamps will not illuminate whilst you are overtaking another vehicle and your speed is greater than that of the vehicle you are passing, even though it is in the blind zone.*

The conditions for activating the blind spot detection function include:

- 1 Rear driver assistance system is in the ON state and no faults are present in the system.
- 2 Blind spot detection (BSD) function is enabled.
- 3 The vehicle speed is above 20mph (30km/h).
- 4 There are motor vehicles in the blind zone of the vehicle. The system monitors both the left and right

### Lane Change Assist (LCA)

When the vehicle is driving forward, the system will monitor for motor vehicles approaching rapidly in the adjacent lanes. When the indicators are activated, and the conditions for activating the lane change assist function are met, the system will flash the respective warning lamp to warn the driver of an approaching vehicle. This aims to help avoid collisions when changing lanes.

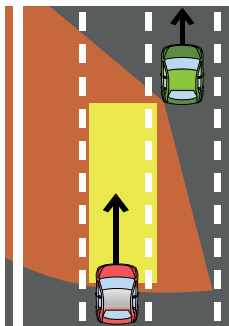

The conditions for activating the lane change assist function include:

- 1 Rear driver assistance system is in the ON state and no faults are present in the system.
- 2 Lane change assist (LCA) function is enabled.
- 3 The vehicle speed is above 20mph (30km/h).
- 4 The speed of the approaching vehicle is higher than the speed of your vehicle.
- 5 The approaching vehicle enters the detection area of the LCA, the monitored areas are 7m - 70m behind your vehicle and 4.7 m to the side of your vehicle.
- 6 The approaching vehicle is likely to have a collision with your vehicle within 3.5 seconds.

# STARTING & DRIVING

---

## Rear Cross Traffic Alert (RCTA)

When the vehicle is reversing, the system will monitor vehicles approaching from the left and right rear. When the conditions for activating RCTA function are met, the warning lamps on the corresponding side will illuminate, simultaneously a warning triangle icon for the corresponding side will be displayed in the infotainment screen to alert the driver to the situation.

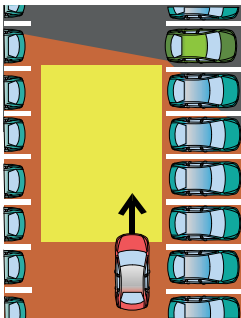

The conditions for activating the rear cross traffic alert function include:

- 1 Rear driver assistance system is in the ON state and no faults are present in the system.
- 2 Rear cross traffic alert (RCTA) function is enabled.
- 3 The vehicle is in Reverse gear.
- 4 The vehicle speed is less than 5mph (9km/h).
- 5 The speed of the vehicle being monitored is above 5mph (9km/h).
- 6 The motor vehicle drives across the system detection areas. The areas monitored to the left and right of the vehicle are 5m behind the rear of the vehicle, and 25m from the side.
- 7 The approaching vehicle is likely to have a collision with your vehicle within 2.5 seconds.

### Door Open Warning (DOW)

Whilst the vehicle is stationary, the Door Open Warning system monitors the surrounding area for approaching vehicles, motorcycles and bicycles.

If the approaching object meets the conditions programmed into the system the corresponding warning light will illuminate to warn the occupant of the approaching object and assist in avoiding any collisions when the door is opened.

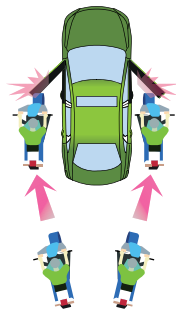

## STARTING & DRIVING

---

The conditions for activating the door open warning function include:

- 1 Rear driver assistance system is in the ON state and no faults are present in the system.
- 2 Door open warning (DOW) function is enabled.
- 3 The vehicle is in ACC or ignition ON/RUNNING state.
- 4 The vehicle is in stationary.
- 5 The speed of the vehicle being monitored is above 5mph (9km/h).
- 6 The vehicle drives across the system detection areas. The detection areas are: Rearward of the door mirrors and 2.4 metres from each side of the vehicle.
- 7 The approaching vehicle is likely to have a collision with your vehicle within 2.5 seconds.

**Note:** *The detection area, collision time threshold value and vehicle speed provided in the system function description are just for your reference.*



## Driving Assist System

The driving assist system includes Speed Assist System (SAS), Lane Departure Warning System (LDW), Lane Departure Prevention System (LDP), Lane Keeping Assist System (LKA), MG Pilot System, Forward Collision Warning System (FCW), Automatic Emergency Braking System (AEB) and Automatic Emergency Braking System for Pedestrians (AEBP). Under certain conditions, the driving assist system can detect the road and environmental information ahead of the vehicle by utilising a front view camera and a front detection radar. This information is used to relay warning messages or provide assistance to help the driver control the vehicle more safely and reliably. The front view camera is located at the upper middle of the windscreen (in the interior rearview mirror base cover) , the front detection radar is located at the lower middle of the front bumper.

## Description of Front View Camera

### Calibration of front view camera

The front view camera will require re-calibration after any of the following operations:

- Removal and refitting of the front view camera.
- Replacement of the windscreen.

**Note: The calibration of front view camera requires professional knowledge and tools. If calibration is required, please seek an MG Authorised Repairer.**

**Note: After completing the calibration it is not possible to immediately select any driving assist options. The vehicle power system must be switched to the OFF position and then switched to ON/READY.**

### Obstruction of the front view camera

On occasion the front view camera view may become obstructed by foreign objects or stains on the glass. In these cases a prompt message will appear in the information centre. Please clean or wipe immediately.

## STARTING & DRIVING

---

**In the following situations, the detection performance of front view camera will be affected:**

- Driving in poor weather conditions where visibility is reduced due to thick fog, heavy rain or snow etc.
- The front view camera is affected by light, for example low light levels at night, poor auxiliary lighting, excessive backlighting in the view, light from oncoming vehicles, abrupt change of brightness such as quick bright/dark jump (tunnel entrance/exit), driving on surfaces with strong reflective properties (road surface covered with water or snow), or driving in places with insufficient light, such as tunnels, surrounded by tall buildings, underground parking lots, etc.
- The front view camera is partially or fully blocked by obstacles, e.g. dust, foreign objects on the windscreen.
- The windscreen in view is damaged.
- Not calibrated after removing/refitting the front view camera.
- Not calibrated after removing/refitting the windscreen.
- The front view camera is not secured in place.

- The outer surface of the windscreen is not clean (including wiper sweep).
- The windscreen is not cleaned regularly.
- The demist/defrost action on the windscreen inefficient in wet conditions.

### **Description of Front Detection Radar**

#### **Calibration of front detection radar**

Front detection radar re-calibration is required after any of the following:

- Front detection radar mis-alignment failure, for example the position of the front detection radar has changed.
- Remove/refit the front detection radar or radar bracket.
- Remove/refit the front anti-collision beam.
- The four-wheel alignment parameters or the driving axis have changed.

**Note: *If the front detection radar is subject to strong vibration or slight impact, the mounting position of the front detection radar needs to be checked and re-calibrated as necessary.***

**Note:** *The calibration of front detection radar requires professional knowledge and tools. If calibration is required, please seek an MG Authorised Repairer.*

**Front radar performance will be effected in the following situations:**

- When the front detection radar is covered by mud, snow, excessive water (rain) or water spray from the road.
- When the radar or surrounding areas are covered by objects such as self-adhesive labels or auxiliary lamps.
- Some targets may affect and weaken the detection capability of the front detection radar, such as road barriers, fences and tunnel entrances.
- When the front detection radar is subject to strong vibration or slight impact.
- When the front detection radar is affected by the environment, such as strong electromagnetic field interference or due to the target itself.

**Note:** *Any snow that gathers on the front radar may be removed using a soft brush, and any ice should be removed using a propriety deicing spray.*

**Note:** *Avoid any collision or contact with the front radar module, this may cause misalignment. Any damage, however slight, may cause system performance issues.*

## STARTING & DRIVING

---

### Speed Assist System (SAS)



*The intelligent speed limit is an auxiliary function, it may display an incorrect speed limit value or no speed limit value in the instrument pack due to various factors. As a result, the vehicle speed is not restricted within the correct range. The driver still needs to observe the speed limit of the road traffic, and speeding is strictly prohibited.*



*The front view camera cannot recognise speed limit signs painted on the road surface. The driver **MUST** observe these speed limits and adjust their speed accordingly.*

The speed assist system settings are available via the infotainment system. When the adaptive cruise control system is OFF, the following three functions can be selected:



- 1 Speed Limit Information Function (SLIF): The vehicle detects a speed limit sign (as shown above) at the roadside with the front view camera. The speed limit sign identified will be displayed on the instrument pack. When the vehicle speed exceeds the speed limit by a preset amount, a visual warning in the instrument pack will alert the driver to control the speed manually.
- 2 Manual Speed Assist (MSA): The driver sets the maximum speed using the adaptive cruise control lever. The system will actively intervene and keep the vehicle speed within the permitted maximum speed limit. And an acoustic warning and a visual warning will be available during the intervention. Please refer to the section “Speed settings of manual speed assist”.
- 3 Intelligent Speed Assist (ISA): The vehicle detects a speed limit sign (as shown above) at the roadside with the front view camera. The speed limit sign identified will be displayed on the instrument pack. The system will automatically intervene and maintain speed control to keep the vehicle speed within the permitted maximum speed limit. And an acoustic

warning and a visual warning will be available during the intervention.

**Note:** *It is recommended to switch off the speed limit information function and intelligent speed assist function when the km/h speed units are selected. In such situations, the system will only recognize the number displayed in all speed limit signs and use this data for km/h, even if the speed limit sign refers to mph. When km/h is selected, the system will also recognize the national speed limit sign as a speed limit sign of 60km/h.*

### Speed assistance system setting

The operating interface for the speed assistance system is located in the infotainment display. Enter the vehicle setting interface to locate the driving assist option, scroll across the page to find the setting interface for the speed assistance system:

- 1 The speed limit information function defaults to enable after the START/STOP Switch is set to ON/RUNNING. Press the UP/DOWN/LEFT/RIGHT button in the RH steering wheel multifunction switch

pack to select the current speed option in the trip computer. Under this interface, long pressing the OK button to turn on/off the speed limit information function.

- 2 Touch the corresponding button on the infotainment display to select the speed assist mode: manual speed assist and intelligent speed assist.

### Speed settings of manual speed assist:

After the manual speed assist function is enabled, the speed limit value can be set by using the adaptive cruise control lever as follows:

- 1 With the manual speed assist function enabled, the initial speed limit value is displayed as “—” on the instrument pack. Move the adaptive cruise control lever up and down (1 and 2 in the figure below) to adjust the target speed limit value. Moving the lever up or down once will increase or decrease the target speed by 5mph (5km/h). Holding the lever up or down, the speed limit value will continuously change in units of 5mph (5km/h). Press the SET button (3 in the figure below), the manual speed assist function will be

## STARTING & DRIVING

activated. When the current actual speed is lower than 20mph (30km/h), the speed limit value displayed on the instrument pack is defined as 20mph (30km/h). If the current actual speed ( $\geq 20$ mph (30km/h)) is higher than the set speed limit value, the speed limit value displayed on the instrument pack will be defined by the current actual speed.

- 2 After the manual speed assist function is activated, the driver can still set the vehicle speed by moving the adaptive cruise control lever up and down. If the current actual speed exceeds the speed limit value set by the driver, the system will immediately reduce the speed until it is below the set speed.
- 3 After the manual speed assist function is activated, the driver can press the SET button (3 in the figure below) on the adaptive cruise control lever to reinstate the system to standby state. Press the SET button again, the manual speed assist function will be resumed. The instrument pack will display the set speed limit value.

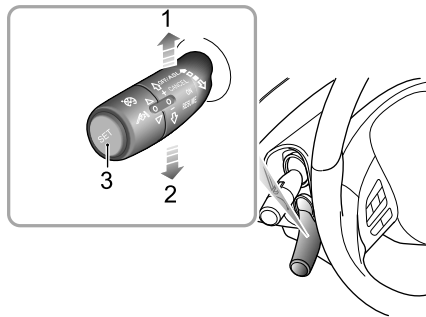

When the speed limit information function or intelligent speed assist function is enabled, the speed limit value indication illuminates. The “NNN” is displayed as “—”. When the vehicle passes the first speed limit sign identified, the speed limit indication displays the real-time speed limit value.

**Note:** When the vehicle needs to change lane, make a turn or turn around at an intersection and the driver uses an indicator in advance and slows down, the original speed limit value on the instrument pack will be reset and displayed as “—” until a new speed limit sign is detected. If the conditions are not met, the original speed limit value will be maintained and not be reset. The driver **MUST** observe the speed limits and adjust their speed accordingly.



When the national speed limit sign is identified and the speed limit information function or intelligent speed assist function is enabled, the national speed limit indication illuminates. These two functions will work using 60mph as the national speed limit.



When the intelligent speed assist function is enabled, the system indicator lamp on the instrument pack illuminates green. If the intelligent speed assist function detects a fault or failure, the indicator lamp will flash yellow then extinguish. Please try to restart this function. If

this function cannot be turned on, please contact an MG Authorised Repairer.



When the speed limit information function or intelligent speed assist function is enabled, and the front view camera detects a speed limit sign with text message below, the warning lamp illuminates yellow to remind the driver to recognise the text message by themselves. The camera cannot recognise the text messages provided below the speed limit sign, such as auxiliary lane, 100m ahead, school section, 7:00-10:00. The camera will recognise the speed limit sign with text messages as a normal speed limit sign. The driver is required to make correct judgement according to the text message.



When the manual speed assist function is enabled, the system indicator lamp on the instrument pack illuminates yellow. When the function is activated by pressing the SET button on the adaptive cruise control lever, the system indicator lamp illuminates green. If the actual speed exceeds the maximum value that can be set, the system will remain in the standby state, and the

## STARTING & DRIVING

---

indicator lamp remains yellow. If the manual speed assist function detects a fault or failure, the indicator lamp will flash yellow then extinguish. Please try to restart this function. If this function cannot be turned on, please contact an MG Authorised Repairer.



NNN  
mph

When the manual speed assist function is enabled, the speed limit value indication illuminates. The “NNN” is displayed as “—”. Move the adaptive cruise control lever up and down to adjust the target speed limit value. The “NNN” will now show the adjusted speed limit value.

The driver can directly switch off, or temporarily suspend the speed assist system by carry out the following actions:

- 1 To temporarily exceed the speed limit (overtaking manoeuvre), press the accelerator pedal hard. The indicator lamp in the instrument pack illuminates green, and the speed limit value flashes.
- 2 Gently press the SET button on the end of the adaptive cruise control lever, the indicator lamp in the

instrument pack will change to yellow. Press the SET button again to resume the functions.

- 3 Move the adaptive cruise control lever to “ON” position to switch the speed assistance system off. Then the indicator lamp in the instrument pack will extinguish.

### **The speed limit information function and intelligent speed limit function may be impaired in the following situations:**

- 1 The detection performance of front view camera is affected.
- 2 The vehicle is driven at a high speed.
- 3 The speed limit signs are blocked by trees along the road, ice/frost, snow, dust, etc.
- 4 The speed limit signs are incorrectly placed or damaged.
- 5 There are multiple speed limit signs above the lane or on the sides of the road. Currently, the front view



camera can only recognise the speed limit signs for the lane in which the vehicle is being driven.

- 6 Non standard speed limit signs or signs that contain additional information.
- 7 The speed limit signs set up at a fork in the road, on a bend or on-ramp/off-ramp.
- 8 During manoeuvres such as lane-changing.

### IMPORTANT

- The camera may not correctly recognise speed limit signs during poor lighting conditions, bad weather, non-standardized or sheltered speed limit signs or the camera's own restrictions which include the recognition of similar signs (e.g., recognise a weight limit sign as a speed limit sign, or recognise a minimum speed sign as the maximum speed sign).
- Some drastic or rapid steering operations made by the driver may be judged as changing lane or turning around at an intersection by the system. This will result in the identified speed limit signs being cleared.

### Lane Departure Warning System (LDW)



*The lane departure warning system is an auxiliary system that provides assistance to the driver. It does NOT remove the responsibility of safe driving from the driver. When choosing to use the lane departure warning system, the driver MUST always pay attention to the surroundings, hold the steering wheel and be prepared to make manoeuvres at any time. Failure to maintain overall control of the vehicle may result in an accident or personal injury.*



*The lane departure warning system does not always recognise the lane line. Sometimes poor road surfaces, certain road structures or objects may be mistaken for lane lines. When such situations occur, the lane departure warning system must be immediately turned off.*

## STARTING & DRIVING

---

The lane departure warning system uses the front view camera to detect the lane lines ahead of the vehicle. The system will operate when the following detection conditions are met:

- The function is switched ON.
- Vehicle speed is above 37mph (60km/h).
- Lane line markings are clear.

As long as the system recognises at least one lane line the indicator lamp in the instrument pack will illuminate green. When a wheel is about to cross the lane line, or has already crossed the line, the following warnings will be provided to prompt the driver to take action and maintain the vehicle position between the lane lines:

- An audible warning sound is emitted.
- A visible warning depicting a car passing a lane line is displayed in the information message centre in the instrument pack.
- The steering wheel produces a vibration warning.

The function will automatically exit when the vehicle speed drops below 33mph (55km/h).

### Lane departure warning system setting

The operating interface for the lane departure warning system is located in the infotainment display. Enter the vehicle setting interface to locate the driving assist option, scroll across the page to find the setting interface for the lane assist system:

- 1 Touch the corresponding button in the infotainment display to turn on/off the lane assist system. Select alert in the assist mode to switch on the lane departure warning system. The system defaults to the last selected state from when the START/STOP Switch was ON/RUNNING.
- 2 Touch the corresponding button in the infotainment display to turn on/off the audible alert. The system defaults to the last selected state from when the START/STOP Switch was ON/RUNNING.
- 3 Touch the corresponding button in the infotainment display to adjust the alert sensitivity. The system defaults to the last selected state from when the START/STOP Switch was ON/RUNNING.

- 4 Touch the corresponding button in the infotainment display to turn on/off the vibration alert. The system defaults to the last selected state from when the START/STOP Switch was ON/RUNNING.

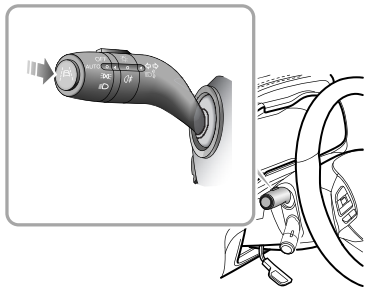

Having turned the lane departure warning system on in the infotainment display, press the button at the end of the indicator stalk switch (as shown above). The lane departure warning system will enter the standby or active

state. The system defaults to the last selected state from when the START/STOP Switch was ON/RUNNING.

When the lane departure warning system is in the standby or active state, you can temporarily disable the function by pressing the button at the end of the indicator stalk switch (as shown above). Pressing the button again will resume the function.



When the lane departure warning function is enabled, the indicator lamp illuminates yellow. When the function is enabled and the vehicle speed is above 37mph (60km/h), the indicator lamp remains green. When the function is disabled, the system indicator lamp extinguishes and the message centre in the instrument pack displays a prompt message. If the lane departure warning system detects a fault or failure, the indicator lamp will flash yellow for 90s, and then remain on.

## STARTING & DRIVING

---

### The lane departure warning system will be impaired in the following conditions:

- The front view camera is obstructed or it is impossible for the camera to detect the lane line ahead due to weather and environmental factors.
- The lane line is too thin, damaged, or fuzzy.
- The vehicle is driven on the bend with a small curvature radius.
- The width of the road is too narrow or too wide.
- The vehicle is driven on a road section without lane lines.
- The vehicle has just entered a road section with lane lines.
- The vehicle changes lanes.
- The vehicle is not in D.
- The vehicle sways laterally too fast.
- The vehicle speed is below 33mph (55km/h), or above 93mph (150km/h).
- The anti-lock brake system (ABS) and the dynamic stability control system (SCS) are activated.

- Faults exist in the anti-lock brake system (ABS), dynamic stability control system (SCS), electric power steering system (EPS), etc.

#### IMPORTANT

The lane departure warning system will not provide an alert in the following situations:

- The driver indicates in the direction of the lane line about to be crossed.
- The hazard lamps are activated.
- The driver applies the accelerator rapidly, carries out an emergency manoeuvre or makes a hard brake pedal application.

It is recommended to turn off the lane departure warning system in the following situations:

- Driving in a sports style or manner.
- Driving in bad weather conditions.
- Driving on rough or poor road surfaces.
- Driving through roadworks or construction sites.

### Lane Departure Prevention System (LDP)



*The lane departure prevention system is an auxiliary system that provides assistance to the driver. It does NOT remove the responsibility of safe driving from the driver. When choosing to use the lane departure prevention system, the driver MUST always pay attention to the surroundings, hold the steering wheel and be prepared to make manoeuvres at any time. Failure to maintain overall control of the vehicle may result in an accident or personal injury.*



*The lane departure prevention system does not always recognise the lane lines. Sometimes poor road surfaces, certain road structures or objects may be mistaken for lane lines. When such situations occur, the lane departure prevention system must be immediately turned off.*

The lane departure prevention system uses the front view camera to detect the lane lines ahead of the vehicle. The system will operate when the following detection conditions are met:

- The function is switched ON.
- Vehicle speed is above 37mph (60km/h).
- Lane line markings are clear.

As long as the system recognises at least one lane line the indicator lamp in the instrument pack will illuminate green. When a wheel is about to cross the lane line, or has already crossed the line, the system will provide assistance to the driver by keeping the vehicle in between the lane lines by applying corrective steering intervention and simultaneously displaying a prompt. The function will automatically exit when the vehicle speed drops below 33mph (55km/h).

In cases of two or more consecutive interventions within an accumulated interval of 180 seconds and in the absence of detecting any steering input by the driver during the intervention, an acoustic warning is sounded during the second intervention, and any further interventions within the 180 seconds. If there is need for, and starting with

## STARTING & DRIVING

---

the third intervention, the acoustic alarm warning will continue longer than the previous warning signal. The lane departure prevention function will exit after five interventions in the absence of a steering input by the driver being detected during the interventions.

### Lane departure prevention system setting

The operating interface for the lane departure prevention system is located in the infotainment display. Enter the vehicle setting interface to locate the driving assist option, scroll across the page to find the setting interface for the lane assist system:

- 1 Touch the corresponding button in the infotainment display to turn on/off the lane assist system. Select departure assist in the assist mode to switch on the lane departure prevention system. The system defaults to the last selected state from when the START/STOP Switch was ON/RUNNING.
- 2 Touch the corresponding button in the infotainment display to turn on/off the audible alert. The system defaults to the last selected state from when the START/STOP Switch was ON/RUNNING.

- 3 Touch the corresponding button in the infotainment display to adjust the alert sensitivity. The system defaults to the last selected state from when the START/STOP Switch was ON/RUNNING.
- 4 Touch the corresponding button in the infotainment display to turn on/off the vibration alert. The system defaults to the last selected state from when the START/STOP Switch was ON/RUNNING.

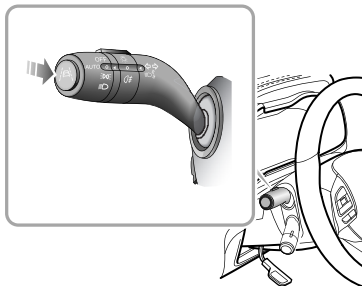

Having turned the lane departure prevention system on in the infotainment display, press the button at the end of the indicator stalk switch (as shown above). The lane departure prevention system will enter the standby or active state. The system defaults to the last selected state from when the START/STOP Switch was ON/RUNNING.

When the lane departure prevention system is in the standby or active state, you can temporarily disable the function by pressing the button at the end of the indicator stalk switch (as shown above). Pressing the button again will resume the function.



When the lane departure prevention function is enabled, the indicator lamp illuminates yellow. When the function is enabled and the vehicle speed is above 37mph (60km/h), the indicator lamp remains green. When the function is disabled, the system indicator lamp extinguishes and the message centre in the instrument pack displays a prompt message. If the lane departure prevention system detects a fault or failure, the indicator lamp will flash yellow for 90s, and then remain on.

### **The lane departure prevention system will be impaired in the following conditions:**

- The system detects that the driver has not moved the steering wheel for a preset time period.
- During system intervention the steering wheel is turned in the opposite direction.
- The front view camera is obstructed or it is impossible for the camera to detect the lane line ahead due to weather and environmental factors.
- The lane line is too thin, damaged, or fuzzy.
- The vehicle is driven on the bend with a small curvature radius.
- The width of the road is too narrow or too wide.
- The vehicle is driven on a road section without lane lines.
- The vehicle has just entered a road section with lane lines.
- The vehicle changes lanes.
- The vehicle is not in D.
- The vehicle sways laterally too fast.

## STARTING & DRIVING

---

- The vehicle speed is below 33mph (55km/h), or above 93mph (150km/h).
- The anti-lock brake system (ABS) and the dynamic stability control system (SCS) are activated.
- Faults exist in the anti-lock brake system (ABS), dynamic stability control system (SCS), electric power steering system (EPS), etc.

### IMPORTANT

The lane departure prevention system will not operate in the following situations:

- The driver indicates in the direction of the lane line about to be crossed.
- The hazard lamps are activated.
- The driver applies the accelerator rapidly, carries out an emergency manoeuvre or makes a hard brake pedal application.

### IMPORTANT

- In cases where the number of lanes increase or lanes merge the driver **MUST** take full control of the vehicle.
- In areas where there are complex traffic conditions such as intersections or road junctions with congestion, the driver **MUST** take full control.

It is recommended to turn off the lane departure prevention system in the following situations:

- Driving in a sports style or manner.
- Driving in bad weather conditions.
- Driving on rough or poor road surfaces.
- Driving through roadworks or construction sites.



### Lane Keeping Assist System (LKA)



*The lane keeping assist system is an auxiliary system that provides assistance to the driver. It does NOT remove the responsibility of safe driving from the driver. When choosing to use the lane keeping assist system, the driver MUST always pay attention to the surroundings, hold the steering wheel and be prepared to make manoeuvres at any time. Failure to maintain overall control of the vehicle may result in an accident or personal injury.*



*The lane keeping assist system does not always recognise the lane line. Sometimes poor road surfaces, certain road structures or objects may be mistaken for lane lines. When such situations occur, the lane keeping assist system must be immediately turned off.*

The lane keeping assist system uses the front view camera to detect the lane lines ahead of the vehicle. The system

will operate when the following detection conditions are met:

- The function is switched ON.
- Vehicle speed is above 37mph (60km/h).
- Lane line markings are clear.

As long as the system recognises two lane lines on both sides the indicator lamp in the instrument pack will illuminate green. The system will always attempt to maintain the vehicle position in the centre of the lane by using corrective steering interventions. If the vehicle deviates from the lane lines the system will activate the lane departure warning function to alert the driver that the vehicle has deviated from the lane. The driver can take corrective action at any time. The function will automatically exit when the vehicle speed drops below 33mph (55km/h).

In the absence of a steering input from the driver for some seconds, an acoustic warning is provided, the instrument pack provides a yellow prompt. If the system still fails to see an input from the driver, the acoustic warning becomes continuous and the prompt illuminates red. If the system still fails to detect an input from the driver, it will assume

## STARTING & DRIVING

---

the driver is not able to keep their hands on the steering wheel and automatically exit the function. Accompanied by the exit, a more urgent acoustic warning is provided for at least 5s or until the driver holds the steering control again.

### Lane keeping assist system setting

The operating interface for the lane keeping assist system is located in the infotainment display. Enter the vehicle setting interface to locate the driving assist option, scroll across the page to find the setting interface for the lane assist system:

- 1 Touch the corresponding button in the infotainment display to turn on/off the lane assist system. Select lane keeping in the assist mode to switch on the lane keeping assist system. The system defaults to the last selected state from when the START/STOP Switch was ON/RUNNING.
- 2 Touch the corresponding button in the infotainment display to turn on/off the audible alert. The system defaults to the last selected state from when the START/STOP Switch was ON/RUNNING.

- 3 Touch the corresponding button in the infotainment display to adjust the alert sensitivity. The system defaults to the last selected state from when the START/STOP Switch was ON/RUNNING.
- 4 Touch the corresponding button in the infotainment display to turn on/off the vibration alert. The system defaults to the last selected state from when the START/STOP Switch was ON/RUNNING.

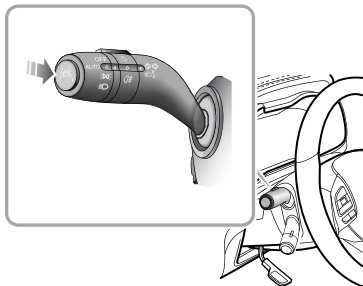

Having turned the lane keeping assist system on in the infotainment display, press the button at the end of the indicator stalk switch (as shown above). The lane keeping assist system will enter the standby or active state. The system defaults to the last selected state from when the START/STOP Switch was ON/RUNNING.

When the lane keeping assist system is in the standby or active state, you can temporarily disable the function by pressing the button at the end of the indicator stalk switch (as shown above). Pressing the button again will resume the function.



When the lane keeping assist function is enabled, the indicator lamp illuminates yellow. When the function is enabled and the vehicle speed is above 37mph (60km/h), the indicator lamp remains green. When the function is disabled, the system indicator lamp extinguishes and the message centre in the instrument pack displays a prompt message. If the lane keeping assist system detects a fault or failure, the indicator lamp will flash yellow for 90s, and then remain on.

### The lane keeping assist system will be impaired in the following conditions:

- The system detects that the driver has not moved the steering wheel for a preset time period.
- During system intervention the steering wheel is being manipulated by the driver.
- The front view camera is obstructed or it is impossible for the camera to detect the lane line ahead due to weather and environmental factors.
- The lane line is too thin, damaged, or fuzzy.
- The vehicle is driven on the bend with a small curvature radius.
- The width of the road is too narrow or too wide.
- The vehicle is driven on a road section without lane lines.
- The vehicle has just entered a road section with lane lines.
- The vehicle changes lanes.
- The vehicle is not in D.
- The vehicle sways laterally too fast.

## STARTING & DRIVING

---

- The vehicle speed is below 33mph (55km/h), or above 93mph (150km/h).
- The anti-lock brake system (ABS) and the dynamic stability control system (SCS) are activated.
- Faults exist in the anti-lock brake system (ABS), dynamic stability control system (SCS), electric power steering system (EPS), etc.

### IMPORTANT

The lane keeping assist system will not operate in the following situations:

- The driver indicates in the direction of the lane line about to be crossed.
- The hazard lamps are activated.
- The driver applies the accelerator rapidly, carries out an emergency manoeuvre or makes a hard brake pedal application.

### IMPORTANT

- In cases where the number of lanes increase or lanes merge the driver **MUST** take full control of the vehicle.
- In areas where there are complex traffic conditions such as intersections or road junctions with congestion, the driver **MUST** take full control.

It is recommended to turn off the lane keeping assist system in the following situations:

- Driving in a sports style or manner.
- Driving in bad weather conditions.
- Driving on rough or poor road surfaces.
- Driving through roadworks or construction sites.

### MG Pilot System \*



*The assistant technology used in the MG pilot system cannot replace the driver's judgment on the road and traffic conditions. The system can provide assistance for the driver but cannot replace the driver in driving. When choosing to use the MG pilot system, due to the limitations of system detection and control, the driver must always be careful. Failure to maintain overall control of the vehicle may result in an accident or personal injury.*



*The MG pilot system is a driver assistance function, it's not auto pilot. There are many situations where the function is restricted or exits. The driver needs to hold the steering wheel at all times and correct or take over the steering wheel control if necessary.*

The MG pilot system needs to be used in conjunction with the adaptive cruise control system. The MG pilot system

works on the basis of the adaptive cruise control system. If the lane lines ahead on both sides are clear, the system can assist the vehicle in driving within the lane lines. When driving at a speed lower than 37mph (60km/h), if there is a vehicle ahead and the lane lines ahead on both sides aren't clear, the system also can assist the vehicle in following the track of the vehicle ahead.

**Note:** *The driver should adjust the vehicle speed and the following distance according to the road visibility, weather and road conditions. The MG pilot system does not respond to pedestrians, animals, stationary vehicles and vehicles that drive across the lane or oncoming vehicles in the same lane. If the MG pilot system cannot reduce the vehicle speed adequately, the driver **MUST** apply the brakes. In congested conditions, should another vehicle cut into the lane being used by the vehicle under MG pilot control, the system may not detect the vehicle in adequate time to make a braking manoeuvre. In this case the brakes should be applied by the driver.*

In the absence of a steering input from the driver for some seconds, an acoustic warning is provided, the instrument

## STARTING & DRIVING

---

pack provides a yellow prompt. If the system still fails to see an input from the driver, the acoustic warning becomes continuous and the prompt illuminates red. If the system still fails to detect an input from the driver, it will assume the driver is not able to keep their hands on the steering wheel and automatically exit the function. Accompanied by the exit, a more urgent acoustic warning is provided for at least 5s or until the driver holds the steering control again.

**Note:** *When the driver uses this function to follow the track of the vehicle in front, the driver **MUST** pay attention to the surrounding environment. Overall responsibility for direction and braking of the car remains with the driver.*

### MG pilot system setting

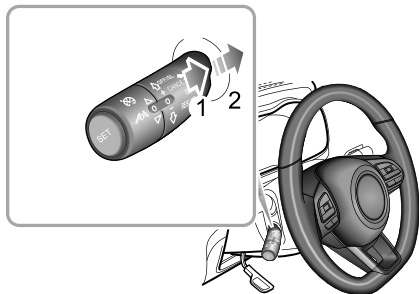

The operating interface for the MG pilot system is located in the infotainment display. Enter the vehicle setting interface to locate the driving assist option, scroll across the page to find the setting interface for the MG Pilot system. The driver may select to turn it on/off. To use the MG pilot system, the adaptive cruise control system must be turned on at the same time. When the function

is turned off, the message centre in the instrument pack will display the corresponding prompt.

Turn the adaptive cruise control level to “RESUME” twice will switch the MG pilot system from standby to active state.



When the MG pilot function is enabled, the indicator lamp illuminates yellow. When the function is active, the indicator lamp illuminates green. When the function is disabled, the system indicator lamp extinguishes and the message centre in the instrument pack displays the prompt message. If the MG pilot system detects a fault or failure, the indicator lamp will flash yellow for 90s, and then remain on.

### **Technical requirements for using MG pilot system:**

- The adaptive cruise control system must be activated.
- The MG pilot system must be switched on via the corresponding button in the infotainment system.

- If the vehicle speed is below 37mph (60km/h), the system must be able to detect lane lines on both sides of the vehicle or a target vehicle directly ahead.
- If the vehicle speed is greater than 37mph (60km/h), the system must be able to detect lane lines on both sides of the vehicle.
- The vehicle is in D.

### **The MG pilot system will be impaired in the following conditions:**

- The system detects that the driver has not moved the steering wheel for a preset time period.
- During system intervention the steering wheel is being manipulated by the driver.
- The technical requirements for MG pilot system are not met.
- The front view camera is obstructed or it is impossible for the camera to detect the lane line ahead due to weather and environmental factors.
- The lane line is too thin, damaged, or fuzzy.
- The vehicle is driven on the bend with a small curvature radius.

## STARTING & DRIVING

---

- The width of the road is too narrow or too wide.
- The vehicle is driven on a road section without lane lines.
- The vehicle has just entered a road section with lane lines.
- The vehicle changes lanes.
- The vehicle is not in D.
- The vehicle sways laterally too fast.
- The vehicle speed is below 33mph (55km/h), or above 111mph (180km/h).
- The anti-lock brake system (ABS) and the dynamic stability control system (SCS) are activated.
- Faults exist in the anti-lock brake system (ABS), dynamic stability control system (SCS), electric power steering system (EPS), etc.

It is recommended to turn off the MG pilot system in the following situations:

- Driving in a sports style or manner.
- Driving in bad weather conditions.
- Driving on rough or poor road surfaces.
- Driving through roadworks or construction sites.

- Driving through complicated road sections (such as urban sites and intersections).
- Driving on steep or excessively winding roads in low visibility.
- Driving on grass tracks or unpaved roads.

### IMPORTANT

The MG pilot system will not operate in the following situations:

- The driver indicates.
- The hazard lamps are activated.
- The driver applies the accelerator rapidly, carries out an emergency manoeuvre or makes a hard brake pedal application.



### IMPORTANT

- In cases where the number of lanes increase or lanes merge the driver **MUST** take full control of the vehicle.
- In areas where there are complex traffic conditions such as intersections or road junctions with congestion, the driver **MUST** take full control.
- The driver **MUST** be aware of the surroundings and be able to assume full control of the vehicle when using the MG pilot function to track the car in front should the need arise.

### Forward Collision Warning System (FCW)



*The driver should pay full attention and drive carefully even if the vehicle is equipped with the forward collision warning system.*

The forward collision warning system detects other vehicles and pedestrians ahead using the forward detection radar and front view camera. When the speed is above 18mph (30km/h) and the vehicle is approaching the vehicle or pedestrian ahead rapidly, the system will prompt the driver to slow down in time and keep a relatively safe distance from the vehicle or pedestrian ahead by emitting an audible alert and displaying a prompt in the information message centre in the instrument pack.

**Note:** *When the vehicle speed is between 18 and 52mph (30 and 85km/h), stationary targets can be detected. When the vehicle speed is between 18 and 93mph (30 and 150km/h), moving targets can be detected. When the vehicle speed is between 18 and 39mph (30 and 64km/h), pedestrians can be detected.*

# STARTING & DRIVING

---

## Forward collision warning system setting

The operating interface for the forward collision warning system is located in the infotainment display. Enter the vehicle setting interface to locate the driving assist option, scroll across the page to find the setting interface for the forward collision system.

- 1 Touch the corresponding button in the infotainment display to switch the forward collision system on/off. Select alert in the assist mode to activate the forward collision warning system. When the START/STOP Switch is ON/RUNNING, the switch defaults to ON. When the driver actively selects to turn off the function, the prompt message will be displayed in the information message centre in the instrument pack, and the confirmation message pop up in the infotainment display.
- 2 Touch the corresponding button in the infotainment system to adjust the alert sensitivity. The system defaults to the last selected state from when the START/STOP Switch was ON/RUNNING.



The lamp illuminates yellow when the forward collision warning system is turned off or detects a fault or failure.

## The forward collision warning system will be impaired in the following conditions:

- The front view camera is obstructed or its performance is affected.
- The vehicle is driving on a bend with a small curve radius.
- The vehicle ahead is of a non standard type, or only the side can be detected.
- The vehicle ahead is too large or close making it impossible to make out the complete outline.
- The vehicle is on an excessive gradient or slope.
- The vehicle is in R (AT) or Reverse (MT).
- The vehicle is accelerating or braking excessively hard.
- There are animals, signposts, guardrails, buildings or similar non motorised objects ahead.

### Automatic Emergency Braking System (AEB) and Automatic Emergency Braking System for Pedestrians (AEBP)



*The driver remains responsible for the safety of the entire driving process, even if the vehicle is equipped with automatic emergency braking system and automatic emergency braking system for pedestrians. The driver **MUST** pay full attention and drive carefully. As driver assist systems, the automatic emergency braking system and automatic emergency braking system for pedestrians cannot prevent accidents or avoid collisions in all situations. The driver **MUST** always remain in control to avoid accidents or emergency situations.*



*Emergency braking whilst under the control of the automatic emergency braking system and automatic emergency braking system for pedestrians may cause injuries to the passengers. Therefore, drive carefully and all passengers **MUST** wear seat belts at all times.*



*Ensure the automatic emergency braking system, automatic emergency braking system for pedestrians or vehicle power system is switched off when being towed. If automatic emergency braking system and automatic emergency braking system for pedestrians is enabled when the vehicle is being towed, adverse effects may affect the safety of your vehicle, the towing vehicle and the people around.*

## STARTING & DRIVING



**To avoid the occurrence of accidents, never specially test the functions of automatic emergency braking system and automatic emergency braking system for pedestrians.**

When the switch for the automatic emergency braking system in the infotainment display is ON, the system will detect and monitor the vehicle ahead in the same lane with the forward detection radar and front view camera. When the system detects that there is a risk of collision between the vehicle and the vehicle ahead, the brake system will automatically intervene to decelerate the vehicle, so as to avoid collision accidents or mitigate damage from collision accidents. If the vehicle is braked and stopped, it will remain stationary for about 2s. Then the control of the vehicle will be handed over to the driver.

When the switch for the automatic emergency braking system for pedestrians in the infotainment display is ON, the system will detect and monitor the pedestrians ahead in the same lane with the forward detection radar and front view camera. When the system detects that there is a risk of collision between the vehicle and the pedestrian ahead,

the brake system will automatically intervene to decelerate the vehicle, so as to avoid collision accidents or mitigate damage from collision accidents. If the vehicle is braked and stopped, it will keep stationary for approx. 2s, then the control of the vehicle will be handed over to the driver.

**Note: When the vehicle speed is between 2 and 52mph (4 and 85km/h), stationary targets can be detected. When the vehicle speed is between 2 and 93mph (4 and 150km/h), moving targets can be detected. When the vehicle speed is between 2 and 39mph (4 and 64km/h), pedestrians can be detected.**

### IMPORTANT

- For stationary targets, collisions cannot be completely avoided when the vehicle speed is greater than 27mph (45km/h).
- For moving targets, collisions cannot be completely avoided when the relative speed is greater than 27mph (45km/h).

The automatic emergency braking system and automatic emergency braking system for pedestrians will only be activated if the following conditions are met:

- The dynamic stability control system (SCS) and traction control system (TCS) are fault-free and ON.
- The vehicle is in D or N.
- The airbags are not deployed.

**Note:** *In some cases, the driver may not have anticipated any braking intervention and does not want to apply the brakes whilst the automatic emergency braking system and automatic emergency braking system for pedestrians are braking heavily. the driver can temporarily cancel this operation by heavily pressing the accelerator pedal after ensuring that it is safe to do so.*

### **Automatic emergency braking system and automatic emergency braking system for pedestrians setting**

The operating interface for the AEB/AEBP system is located in the infotainment display. Enter the vehicle

setting interface to locate the driving assist option, scroll across the page to find the setting interface for the forward collision system:

- 1 Touch the corresponding button in the infotainment system to switch the forward collision system on/off. Select emergency braking in the assist mode to activate the automatic emergency braking system. When the START/STOP Switch is ON/RUNNING, the switch of the system defaults to ON. When the driver actively selects to turn off the function, a prompt message will be displayed in the information message centre in the instrument pack and a pop up message will appear in the infotainment display.
- 2 Touch the corresponding button in the infotainment system to switch the automatic emergency braking system for pedestrians on/off. When the START/STOP Switch is ON/RUNNING, the switch defaults to ON. When the driver actively selects to turn off the function, a prompt message will be displayed in the information message centre in the instrument pack and a pop up message will appear in the infotainment display.

## STARTING & DRIVING

---

**Note:** *DO NOT operate any infotainment switches whilst driving. If you wish to make any settings changes please pull over when it is safe and legal to do so.*



The indicator lamp illuminates yellow when the automatic emergency braking system or emergency braking system for pedestrians is turned off or detects a fault or failure.

**The operation of the automatic emergency braking system and automatic emergency braking system for pedestrians may be impaired in the following situations:**

- The detection performance of forward detection radar or front view camera is affected.
- The contour of the vehicle ahead is unclear, for example: water sprayed by the wheels of the front and surrounding vehicles in heavy rain/spray or snow conditions.
- When driving on special road conditions, for example, on a curve or a slope, on the section coming on/off the

bridge, a vehicle ahead, an oncoming vehicle, a vehicle crossing the intersection, a vehicle making a turn, the side of a vehicle or a vehicle jumping the queue rapidly in a short distance is detected.

- There are vehicles running in the opposite direction in the lane, or the vehicle itself runs in opposite direction.
- The vehicle ahead does not have or has obscured tail lamps when driving at night or in a tunnel; the tail lamps of the vehicle ahead are all LED strip lights or other homemade coloured lamps; inconsistent or flickering street lights when driving at night.
- The vehicle ahead is an ultra-large vehicle or a trailer, which is too big to be recognised by the system (such as a tractor, a trailer, a towing vehicle)
- The vehicle ahead does not follow the rules of driving and parking; the vehicle ahead is driving on the lane lines; the vehicle ahead is not in the same lane as your vehicle or the view of vehicle ahead is partially obscured.
- The pedestrian is not directly in front of the vehicle; the pedestrian is not fully visible; the pedestrian is not standing upright; there are a crowd of pedestrians; the

pedestrian is over-shadowed; the pedestrian is in the dark or it is a child under a certain height, etc.

**Note:** *The two systems function only when a vehicle or pedestrian is detected in the same lane ahead. The system cannot recognise any special-shaped ground obstacles (such as roadblocks, isolation piles, isolation strips, large stones and other scattered objects) and animals. The system may not recognize bicycles, motorbikes, small wheeled objects (such as suitcases, shopping carts or wheelchairs), some means of unusual transportation (such as the horse and cart, carriages etc.) and vehicles with higher chassis.*

# STARTING & DRIVING

---

## Load Carrying



**DO NOT** exceed the **gross vehicle weight** or the **permitted front and rear axle loads**. **Failure may result in vehicle damage or serious injury.**

## Load Space



**Ensure that the rear seat backrests are securely latched in the upright position when loads are carried in the load space behind the seats.**



**If the boot lid (or tailgate) can not be closed due to the type of cargo loaded, be sure to close all windows during driving, select the face distribution mode of the air condition, and set the blower to maximum speed, so as to decrease exhaust fumes entering the vehicle.**

When luggage carried in the boot, always ensure heavy items are placed as low and as far forward as possible, so

as to avoid the cargo shift in the event of an accident or sudden stop.

Drive carefully and avoid emergency braking or maneuvers when large or heavy items are carried.

Driving with the boot lid (or tailgate) open is very dangerous. If the load being carried requires the boot lid (or tailgate) to be open, please ensure the cargo and the boot lid (or tailgate) are suitably secured and every measure is taken to prevent exhaust fumes entering the vehicle.

### IMPORTANT

Traffic regulations must be observed when loading cargo, if the cargo extrudes the loadspace, appropriate warning measures must be taken to warn other road users.



### Internal Loading



**DO NOT carry unsecured equipment, tools or luggage that could move, causing personal injury in the event of an accident, emergency braking or hard acceleration.**



**DO NOT obstruct the driver and passengers to keep right sitting posture and observation with loads.**

Folding the rear seats can increase luggage space, refer to "Rear Seat" in "Seats and Restraints" chapter.

When cargo is loaded in the vehicle, place it at a position as low as possible and ensure that it is tightly secured, so as to avoid personal injury caused by cargo movement when traffic accidents or emergency brakes occur. If the cargo has to be put on a seat, no one is allowed to sit on that seat.

### General Towing Safety

Your vehicle can tow a trailer if you carefully observe load limits, use approved equipment, and follow the towing guidelines. Always check load limits before towing.

Towing loads in excess of the maximum towing weight can seriously affect vehicle handling and performance, and could damage your vehicles engine and drive-train.

**Note: Exceeding any load limits advised by MG Motor UK Ltd is dangerous. Consult the recommended load limits and loading prior to any journey.**

**Check the loading of your vehicle and trailer carefully before starting to drive.**

Trailer hitch load should never exceed the limit advised by MG Motor UK Ltd.

**Note: Excessive towing loads reduce front tyre traction and steering control, too little trailer nose load can make the trailer unstable and cause it to sway.**

**Tow bars:** Only genuine MG approved tow bars should be fitted to your vehicle. Only use the attachment method specified by the vehicle manufacturer for securing the

## STARTING & DRIVING

---

towing hitch. Contact your authorised MG dealer for more information.

**Safety chains:** Safety chains must be used as a precautionary measure should the trailer become unintentionally unhitched. Make sure the safety chain is securely attached to both the trailer and the vehicle prior to departure.

**Altitude:** Your engine delivers less power at higher altitude. If you tow a trailer in a mountainous area you should reduce the combined vehicle and trailer weight by 10% for every 1000m of elevation.

**Gradients:** Where possible, when towing, you should plan your journey to avoid steep gradients. The advised brake towing mass stated assumes a maximum gradient capability of 12% where possible it is recommended you drive on gradients less than 12%. Follow the trailer associations recommendations for suitable roads.

**Running in period:** Avoid towing a trailer during your vehicles first 1000 km or 625 miles.

**Stop/Start function:** Manually switch the Automated Stop/Start function OFF when towing. The trailer weight

can affect your vehicles braking efficiency if Automated Stop/Start is activated on a hill while towing a trailer.

## **Emergency Information**

---

*270 Hazard Warning Devices*

*272 eCall - SOS Emergency Assistance*

*274 Emergency Starting*

*276 Vehicle Recovery*

*280 Tyre Repair*

*287 Fuse Replacement*

*294 Bulb Replacement*

## EMERGENCY INFORMATION

---

### Hazard Warning Devices

#### Hazard Warning Lamps

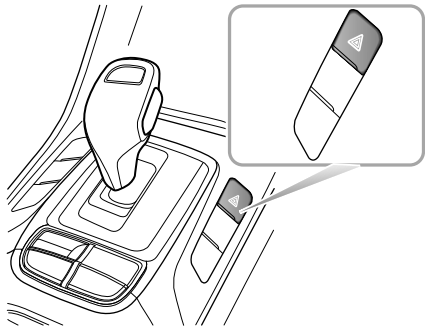

**Note:** Before you stop or slow the vehicle in an emergency, always press the hazard warning switch. All turn signal lamps and direction indicators will flash together to warn other road users when your vehicle is

*causing an obstruction or is in a hazardous situation. Remember to switch them off before driving away.*

#### Warning Triangle

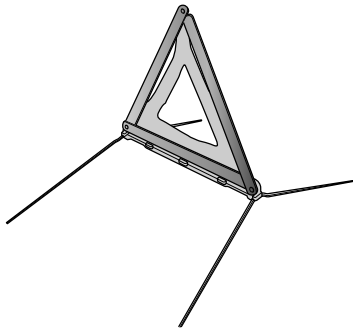

The warning triangle supplied with your vehicle is stowed in the loadspace.

If you have to stop your vehicle on the road in an emergency, you must place a warning triangle

## EMERGENCY INFORMATION

---

approximately 50 — 150 metres behind the vehicle, if possible, to warn other road users of your position.

# EMERGENCY INFORMATION

---

## eCall - SOS Emergency Assistance

In an accident, your vehicle's eCall – SOS Emergency Assistance can either be triggered manually or in severe cases automatically upon detection by vehicle's sensors. The eCall service is a public service of general interest and is accessible free of charge. The emergency call centre will establish verbal communication with the vehicle occupants in order to understand the extent of the emergency and the level of assistance required. If verbal communication is not achievable an attempt will be made to send the following vehicle information message to the emergency call centre. The appropriate emergency services will be deployed to the vehicle's current location if known.

- Current time, location and direction of travel
- Vehicle type
- Vehicle identification number (VIN)
- Whether the call was automatically or manually initiated
- Vehicle category

This system will ensure that your personal data is securely protected. It is designed to ensure that it is not traceable and other external systems are not available . When

the eCall triggers, the system will only transmit the data information to the relevant public safety answering points designated by the respective public authorities of the country on which territory they are located, which will receive and process your emergency call request. The system will retain data locally within 13 hours of triggering.

You have the right to access the data information stored in this system, and to request the rectification, erasure or blocking of data information that does not meet the requirements of the regulations. When you think your personal data is infringed, you have the right to complain to the competent data protection authority.

For manual activation, press and release the SOS button in the overhead console for 1 second to activate an emergency services call. A single beep will be heard when the eCall is triggered and a message will be displayed on the vehicle's message centre and entertainment player. The entertainment player will be muted whilst the emergency services call is active. Manually triggered emergency services calls may be cancelled by pressing and releasing the SOS button again within 5 seconds of the initial press, two beeps will be heard confirming that the emergency

## EMERGENCY INFORMATION

services call has been cancelled and the messages will be removed.

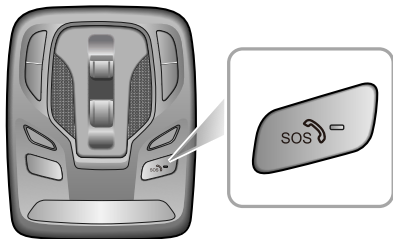

The emergency services call (eCall) system will perform a self-test when the ignition is turned ON. During a Self-Test the emergency services call (eCall) LED status indicator on the SOS button will flash quickly until completion. The LED status indicator will be illuminated solid if no system faults are present. The LED status indicator will be extinctd or

flash slowly if a fault is detected. Faults detected during the self-test will be displayed on the vehicles message centre.

**Note:** *The operation of eCall - SOS Emergency Assistance relies on cellular coverage and may be affected by signal outages or low signal strength.*

**Note:** *The automatic emergency services call (eCall) function may be disabled by the local MG Authorised Repairer upon request.*

# EMERGENCY INFORMATION

## Emergency Starting

### Using Booster Cables



**NEVER** start the engine by pushing or towing.



Make sure that **BOTH** batteries are of the same voltage (12 volts), and that the booster cables are approved for use with 12 volt car batteries.



Ensure sparks and naked lights are kept well away from the engine compartment.

Using booster cables (jump leads) from a donor battery, or a battery fitted to a donor vehicle, is the only approved method of starting a car with a flat battery.

If the battery from a donor vehicle is to be used, the vehicles should be parked with their battery locations adjacent to one another. Ensure that the two vehicles do not touch.

## Starting the Vehicle



Ensure that each booster cable connection is securely made. There must be no risk of the clips accidentally slipping from the battery terminals (as a result of engine vibration, for example), this could cause sparking, which could lead to fire or explosion.

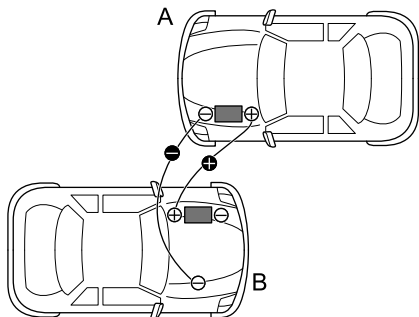



## EMERGENCY INFORMATION

Ensure the START/STOP switch is turned off and switch off ALL electrical equipment of BOTH vehicles, then follow the instructions below:

- 1 Connect the RED booster cable between the positive (+) terminals of both batteries. Connect the BLACK booster cable from the negative (-) terminal of the donor battery (A) to a good earth point (an engine mounting or other unpainted surface, for example), at least 0.5 m from the battery on the disabled vehicle (B).
- 2 Check that the cables are clear of moving parts of both engines, then start the engine of the donor vehicle and allow it to idle for a few minutes.
- 3 Now start the engine of the vehicle with the discharged battery (DO NOT crank the engine for more than 10 seconds). If the disabled vehicle will not start after several attempts, it may need to be repaired. Please contact the MG Authorised Repairer.
- 4 After both the vehicles have normally started, allow the engines to idle for more than 2 minutes before

shutting down the engine of the donor vehicle and disconnecting the booster cables.

### IMPORTANT

NEVER turn on any electrical equipment on the started vehicle before removing the booster cables.

- 5 Disconnecting the booster cables must be an exact reversal of the procedure used to connect them, i.e. disconnect the BLACK cable from the earth point on the disabled vehicle FIRST.

# EMERGENCY INFORMATION

---

## Vehicle Recovery

### Towing for Recovery

#### Towing Eye



**DO NOT** use a tow rope that is twisted - or the towing hook may be unscrewed.

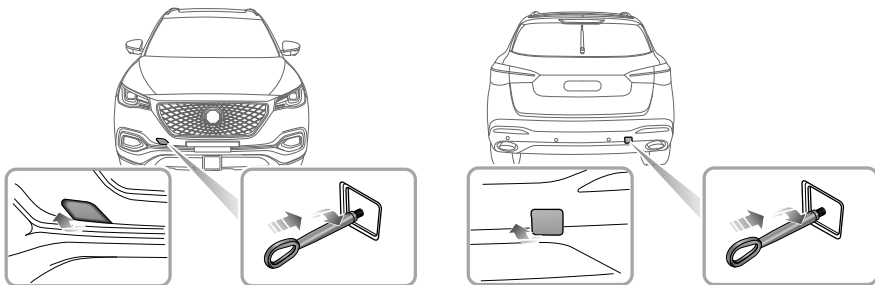

## EMERGENCY INFORMATION

Your car is equipped with 2 towing eyes (located at the front and the rear of the vehicle), which are used for fitting the towing hook in the tool kit. The tool kit is placed beneath the loadspace floor. To fit the towing hook, remove the small cover set into the bumper, then screw the towing hook via the small hole into the threaded hole in the bumper beam (see illustration). Ensure the towing hook is fully tightened!

**Note:** *The small cover removed may be secured to the bumper by a plastic cord.*

Both towing points are intended for use by qualified recovery specialists to assist in the recovery of your vehicle when a breakdown or accident occurs. They are not designed for towing other vehicles, and must NEVER be used to tow a trailer or caravan. The vehicle can be towed using a tow rope but a towing bar is recommended.

### Towing



**When towing, DO NOT suddenly accelerate or brake suddenly, this can cause accidents.**

### Suspended Towing

If your vehicle needs to be towed, most qualified recovery specialists will use wheel lift equipment to suspend the vehicle. Please keep the driving wheels off the ground. Ensure the parking brake is released, the hazard warning lamps are activated and no passengers are left in the vehicle.

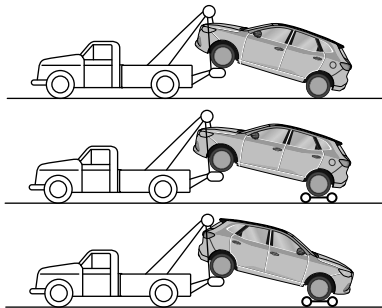

## EMERGENCY INFORMATION

---

### Four-Wheel Touchdown Towing



*If, due to an electrical fault, it is considered unsafe to switch the start/stop switch on, the car will need to be recovered on a trailer.*



*The towing speed of the vehicle shall not exceed 20mph (30km/h) , the towing distance shall not exceed 30miles (50km).*

If your vehicle is towed with the four wheels on the ground, observe the following precautions:

- 1 Operate the start/stop switch to the ON/RUNNING position, this will enable the brake lights, wipers and direction indicators to be operated if necessary.
- 2 Place the shift lever in Neutral (N).
- 3 Release the parking brake.
- 4 Turn on the hazard warning lamps.
- 5 If the transmission is damaged or is subject to a lack of lubricating oil, DO NOT tow the vehicle with four wheels on the ground.

- 6 DO NOT tow backward with front wheels (drive wheels) on the ground.

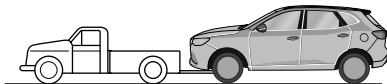

Without the engine running, greater effort will be required to operate the brake pedal and turn the steering wheel. Longer stopping distances will also be experienced.

## EMERGENCY INFORMATION

### Transporter

If your vehicle needs to be shipped, a special transporter is recommended. Secure the vehicle on the transporter as follows:

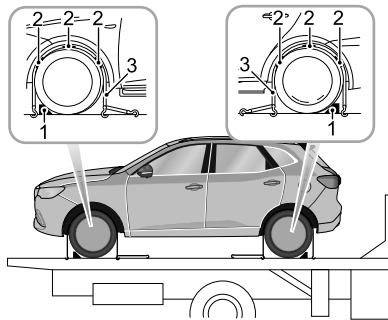

- 1 Apply the parking brake, manual transmission places the shift lever in Neutral (N), automatic transmission places the shift lever in Park (P).

- 2 Place the wheel chock (1) as shown in the figure, then place the anti slip rubber pad (2) around the circumference of the tyre.
- 3 Fit the lashing straps (3) around the wheels and secure to the trailer. Tighten the straps until your vehicle is securely held.

# EMERGENCY INFORMATION

## Tyre Repair

### Tool Identification (including tyre repair tool)

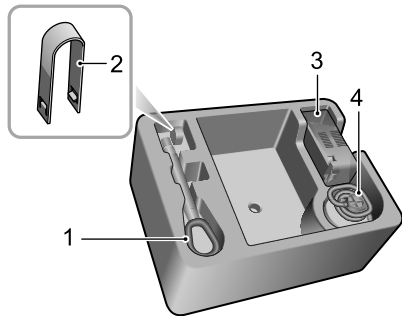

- 1 Towing Hook
- 2 Wheel Bolt Cap Removal Tool
- 3 Electric Air Pump
- 4 Repair Fluid Reservoir

## Tyre Repair

- 1 Remove the label at the bottom of the repair fluid reservoir and attach it to the steering wheel to remind the driver not to exceed 50 mph ( 80 km/h ) .

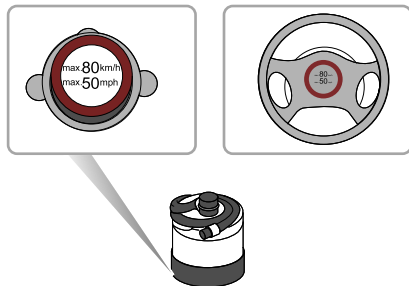

- 2 Connect the air hose of the electric air pump to the repair fluid reservoir. Invert the repair fluid reservoir on the groove of the electric air pump. Remove the valve dust cap of the damaged tyre, and connect the hose connector of the repair fluid reservoir to the

## EMERGENCY INFORMATION

tyre valve. Check if the power switch of the electric air pump is off (with "O pressed), then connect the electric air pump plug to the 12V power socket in the centre console, and switch on the start/stop switch.



**Note:** To avoid battery discharge, it is recommended to keep the engine running.

- 3 Switch on the power switch of the electric compressor (i.e., press “-”), to start pumping sealant into the tyre. The tyre sealant bottle will become empty after approximately 30 seconds. The tyre should reach the specified pressure within 5 to 10 minutes.

**Note:** The pressure gauge may briefly reach 6 bar (87 psi), then the pressure begins to drop to normal.

- 4 When the required pressure is reached, switch off the power switch of the electric compressor (i.e., press “O”).

**Note:** If the required pressure cannot be reached within 10 minutes, please disconnect the compressor, drive the vehicle 10 metres (33 feet) approx forward or backward to allow the sealant to spread within the tyre. If the required pressure can still not be reached, the tyre is severely damaged and you should seek assistance from an MG Authorised Repairer.

## EMERGENCY INFORMATION

**Note:** Continued use of the electric air pump for more than 10 minutes may result in motor overheat and damage.

- Remove the tyre sealant bottle from the slot in the compressor, disconnect the hose from the tyre valve, remove the compressor plug from the centre console power socket, return the tyre repair kit to its stowage tray.
- After successfully adding sealant to the tyre, drive immediately for a short time (around one minute) this will allow the sealant to distribute evenly inside the tyre. Continue driving and do not exceed 50 mph (80 km/h). After a further 10 minutes, find a safe place to stop and recheck the tyre pressure.

Please take different measures based on the tyre pressure measured:

- If the tyre pressure has dropped to less than 0.8 bar (11.6 psi), do not continue driving, seek an MG Authorised Repairer for assistance instead.
- If the tyre pressure is between 0.8 bar (11.6 psi) and 2.3 bar (33.3 psi), connect the hose of electric air pump to

the tyre valve, and connect the plug of the electric air pump to the power socket, then switch on the electric air pump to inflate the tyre until it reaches the required pressure. Repeat the operations of step 6 after driving a maximum distance of 3 miles (5 km).



- If the tyre pressure has not dropped, you may continue driving, but the vehicle speed must not exceed 50 mph (80 km/h), and the driving mileage must not exceed 125 miles (200 km).



## EMERGENCY INFORMATION

**Note: DO NOT** remove foreign objects (eg. screws, nails) from the tyre. The tyre repair system must only be used when the foreign object is in the tread pattern (A), **DO NOT** attempt a repair when the damage is in the sidewall of the tyre (B).

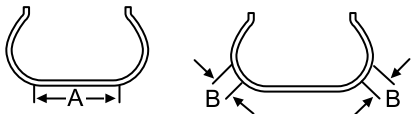

### Changing a Wheel \*

If you need to change the wheel during the journey, choose a safe place to stop away from the main road if possible. Always ask your passengers to get out of the car and wait in a safe area away from other traffic.

Switch on hazard warning lamps. If available, position a warning triangle about 50 to 150 metres behind your vehicle to warn approaching traffic.

Before changing a wheel, ensure the front wheels are in the straight ahead position. Apply the parking brake and place the gear shift lever in Park ( P ).

Observe the following precautions:

- Ensure the jack is positioned on firm, level ground.
- If the vehicle must be parked on the hill, place chocks in front of and behind other 3 wheels to prevent the vehicle moving.

## EMERGENCY INFORMATION

---

### Positioning the Jack



**NEVER** work beneath the car with the jack as the only means of support. The jack is designed for wheel changing only!



**NEVER** jack the car using any positions other than the jacking points. Serious damage to the car could result.



**Avoid** accidental contact with any underbody parts, especially hot exhaust system components.

Position the jack on firm level ground under the jacking point nearest the wheel to be removed. Note that the domed head of the jack must fit into the corresponding recess in the sill plate (There is a triangle indicator in the area shown by the arrowhead. See the illustration below).

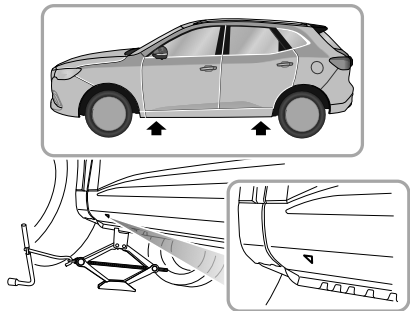

Turning the jack screw handle by hand, adjust the jack until the jack head fits snugly onto the flanging of the body. Ensure that the base of the jack is in full contact with the level ground.

### Fitting the Spare Wheel



**Regularly check the spare wheel tyre pressure, it may be underpressure due to unused for long periods of time. After replacement, at the first opportunity check and adjust the tyre pressure.**



**The wheel bolts must be tightened to the specified torque after changing a wheel (120 ~ 130 Nm).**

- 1 Before raising the car, use the special tool supplied with the vehicle to remove each wheel bolt cap. Use the wheel bolt spanner to slacken each bolt half a turn anti-clockwise.
- 2 Turn the handle in a clockwise direction until the tyre is clear of the ground.
- 3 Remove the wheel bolts and place them in the tool kit to prevent them from being lost. Make sure the vehicle is steady and there is no risk of slip or movement before removing wheel bolts.
- 4 Remove the road wheel.

**Note: Avoid placing wheels face down on the ground - the surface may be scratched.**

- 5 Fit the spare wheel and tighten the wheel bolts with wheel bolt spanner until the wheel is seated firmly against the hub.
- 6 Lower the car and remove the jack, then FULLY tighten the wheel bolts in a diagonal sequence.
- 7 Finally, return the tools to the tool kit, put the tool kit into the boot, tighten the retaining bolts, put down the luggage carpet and put the replaced wheel above the carpet (wheel rim face up).

**Note: DO NOT stand on the handle of the wheel bolt spanner or use extension tube on the handle of the spanner.**

**Note: When replacing the wheel, please fully tighten the bolts in the diagonal sequence twice.**

**Note: Contact an MG Authorised Repairer to replace with a new tyre urgently.**

## EMERGENCY INFORMATION

---

### Spacesaver Spare Wheel



*Only one spacesaver spare wheel can be used at any one time, otherwise the operational performance and brake performance may be reduced, thereby leading to accident or injury to yourself and others.*



*When driving on icy or slippery surfaces it is advised to fit the spacesaver wheel to the rear of the vehicle to maintain adequate stability. This may mean swapping a front wheel with a rear wheel.*



*Snow chains can not be used on the spacesaver spare wheel, this can cause damage to the car and snow chain.*

When the spacesaver spare wheel is fitted, the vehicle speed should not exceed 50 mph (80 km/h). Please have the full-scale tyre repaired and replace the spare wheel as soon as possible. This will extend the life span of the spare wheel for other emergencies.

**Note:** *DO NOT use an automatic car wash when the spacesaver wheel is fitted, the guide rails of the*

*car wash may conflict with the wheel/tyre and cause damage.*

## Fuse Replacement

### Fuse

Fuses are simple circuit breakers which protect the car's electrical equipment by preventing the electrical circuits from being overloaded. A blown fuse may be indicated when the item of electrical equipment it protect stops working.

If a fuse is suspected faulty, you may remove it from the fuse box and observe if the metal wire in the fuse is broken.

It is recommended to have spare fuses in the vehicle, which can be obtained from a local MG Authorised Repairer.

#### IMPORTANT

- NEVER attempt to repair a blown fuse. ALWAYS replace a fuse with one of the same rating, otherwise the fire may be caused due to electrical system damage or circuit overload.
- If a replaced fuse fails immediately, please contact an MG Authorised Repairer as soon as possible.

### Fuse Box

The vehicle is equipped with 2 fuse boxes:

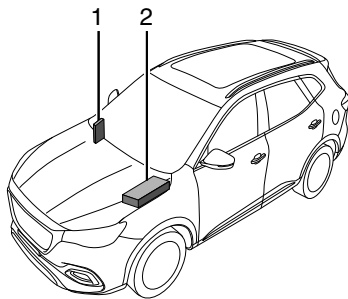

- 1 Passenger compartment fuse box (behind the driver's lower fascia panel)
- 2 Front compartment fuse box (nearside of the engine compartment)

# EMERGENCY INFORMATION

## Front compartment fuse box

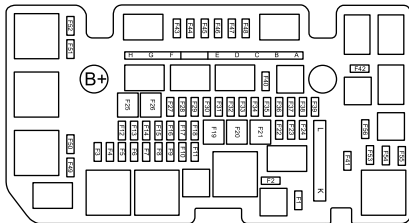

### Check or Replace a Fuse

- 1 Turn the START/STOP Switch and all electrical appliances OFF, and disconnect the battery negative cable.
- 2 Press the lock catch to open the upper cover of Front compartment fuse box.
- 3 Hold the fuse head with the fuse extraction tool in the upper cover, pull and remove the fuse, and check if the fuse is blown.

- 4 If a fuse is blown, replace it with another fuse of the same type and same ampere value.

### Fuse Specification

Code	Specs	Function
F1	-	-
F2	-	-
F3	10A	Front Fog Lamp
F4	25A	Body Control Module
F5	25A	Body Control Module
F6	-	-
F7	10A	Engine Control Module
F8	-	-
F9	15A	Horn
F10	5A	Transmission Gear Shift Actuator
F11	-	-

## EMERGENCY INFORMATION

Code	Specs	Function
F12	25A	Body Control Module
F13	25A	Body Control Module
F14–F19	-	-
F20	30A	DC-DC Converter
F21	30A	DC-DC Converter
F22–F23	-	-
F24	15A	Rear Wiper Relay
F25	30A	DC-DC Converter
F26	25A	Body Control Module
F27	10A	Windscreen/Rear Window Washer Relay
F28	25A	Super Lock Relay
F29	25A	Body Control Module
F30	25A	Front Wiper Relay

Code	Specs	Function
F31–F35	-	-
F36	10A	A/C Compressor Relay
F37	-	-
F38	15A	Fuel Pump Relay
F39	5A	Crank Signal
F40–F42	-	-
F43	5A	DC-DC Converter Relay, Fuel Pump Relay, A/C Compressor Relay, Clutch Position Sensor, Brake Pedal Switch, Neutral Position Sensor, Cooling Fan Relay Box
F44	15A	Electronic Thermostat, VVT Valve - Intake, VVT Valve - Exhaust, Upstream Oxygen Sensor, Downstream Oxygen Sensor, Canister Shut off Valve

## EMERGENCY INFORMATION

Code	Specs	Function
F45	10A	Engine Oil Control Valve, Canister Control Valve, Exhaust Gas Control Valve, Relief Valve
F46	15A	Engine Control Module
F47	15A	Ignition Coil, Air Flow Sensor
F48	-	-
F49	10A	Right Headlamp
F50	10A	Left Headlamp
F51–F56	-	-
MF1 A	80A	Electric Power Steering Control Module
MF1 B	40A	7 -speed Dual Clutch Transmission Control Module Relay
MF1 C	40A	Dynamic Stability Control System (pump)

Code	Specs	Function
MF1 D	40A	Dynamic Stability Control System (valve)
MF1 E	-	-
MF1 F	30A	Starter Relay
MF1 G	-	-
MF1 H	50A	Cooling Fan
MF2 K	100A	Passenger Compartment Fuse Box
MF2 L	30A	Electric Vacuum Pump



## EMERGENCY INFORMATION

### Passenger Compartment Fuse Box

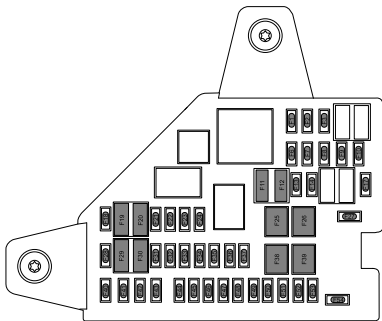

### Check or Replace a Fuse

- 1 Turn the START/STOP Switch and all electrical appliances OFF, and disconnect the battery negative cable.
- 2 Remove the lower trim panel at driver side to access the fuse box.

- 3 Hold the fuse head with the fuse extraction tool in the Front compartment fuse box, pull and remove the fuse, and check if the fuse is blown.
- 4 If a fuse is blown, replace it with another fuse of the same type and same ampere value.

### Fuse Specification

Code	Specs	Function
F1	10A	Supplemental Restraint System Sensing and Diagnostic Module, DC-DC Converter, Communication Module, Shifter Control Unit, Instrument Pack, Body Control Module, SDM Auxiliary Display Module
F2	7.5A	Transmission Control Module, Reverse Lamp Switch, Engine Control Module
F3	5A	Front View Camera Module, Forward Detection Radar

## EMERGENCY INFORMATION

Code	Specs	Function
F6–F7	-	-
F8	15A	Front Console Power Socket
F9	5A	USB Charging Port
F10	-	-
F11	7.5A	Heated Exterior Rearview Mirror
F12	25A	Heated Rear Window
F13–F14	-	-
F17	-	-
F18	30A	Rear Left Window Regulator
F19	5A	EPB Switch, Gear Display
F20	30A	Rear Right Window Regulator
F21	10A	Front Right Seat Heater Relay
F22	5A	Data Link Connector
F23	10A	Heated Front Left Seat

Code	Specs	Function
F24	10A	Gateway
F25	30A	KLR Relay
F26	30A	Passenger Window Regulator
F27	-	-
F28	5A	PEPS Control Unit, Spare Coil
F29	10A	Gateway
F30	5A	Driver Window Combination Switch, Rain/Light Sensor
F31	-	-
F32	5A	Atmosphere Lamp Control Module
F33	5A	Supplemental Restraint System Sensing and Diagnostic Module
F34	5A	Communication Module
F35	10A	Digital Audio Broadcasting (DAB) Module

## EMERGENCY INFORMATION

Code	Specs	Function
F36	10A	Electronic Steering Column Lock Control Module
F37	20A	Driver Power Seat Adjustment
F38	30A	Driver Window Regulator
F39	30A	Blower
F40	15A	Entertainment System
F41	5A	Upper Centre Console Switch
F42	10A	HVAC Control Module
F43	5A	Instrument Pack
F44	5A	Rear Driving Assist System
F45	30A	Sunroof Motor
F46	5A	Tyre Pressure Monitoring System
F47	30A	Sunshade Motor

Code	Specs	Function
F48	20A	Front Passenger Power Seat Adjustment
F49	30A	Power Liftgate Control Module
F50	-	-
F51	30A	Rear Window/Exterior Rearview Mirror Heater Relay
F52	10A	KL15 Switch Relay
F53	20A	Shifter Control Unit
F54	-	-

# EMERGENCY INFORMATION

---

## Bulb Replacement

### Bulb Specification

Bulb	Type
Dipped Beam and Main Beam (low configuration)	HB3SL+ 60W
Front Indicator Lamps (low configuration)	WY21W 21W
Front Fog Lamps	H8 35W
Front Interior Lamps (bulb configuration)	W5W 5W
Reverse Lamps	W16W 16W
License Plate Lamps	W5W 5W

**Note:** *Bulb HB3SL+ is identical with HB3 in shape and structure, and is only superior in reliability and service life.*

**Note:** *Other light sources not included in the list are LED, which cannot be replaced individually.*

## Bulb Replacement

Before replacing any bulb, ensure that the START/STOP Switch and lighting switches are OFF so as to avoid any possibility of a short circuit. When replacing the bulb, actions shall be gentle so as not to damage the lamp.

**Note:** *Only replace bulbs with the same type and specification.*

**Note:** *If the bulb glass is scratched or contaminated, it may cause the bulb can not concentrate the light. Take care NOT to touch the glass with your fingers; If necessary, clean the glass with methyated spirits to remove fingerprints.*

Consult an Authorised MG Repairer on specific replacement operation.

### Dipped/Main Beam Headlamp Bulb Renewal

- 1 Open the bonnet—see “Bonnet” in the “Maintenance” section.
- 2 Disconnect the battery negative terminal.
- 3 Identify and locate the headlamp bulb cover plug, and remove it.
- 4 Rotate the bulb anti-clockwise and remove.
- 5 Remove the wiring connector from the bulb.
- 6 Refit the wiring connector to the new bulb.
- 7 Locate the bulb in the lamp, rotate clockwise until fully secured.
- 8 Locate the cover plug.
- 9 Connect the negative battery terminal.
- 10 Test headlamp operation.
- 11 Close the bonnet—see “Bonnet” in the “Maintenance” section.

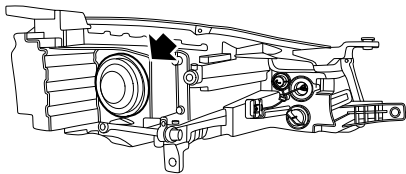

# EMERGENCY INFORMATION

---

## Front Indicator Lamp Bulb Renewal

- 1 Open the bonnet—see “Bonnet” in the “Maintenance” section.
- 2 Disconnect the battery negative terminal.
- 3 Rotate the bulb holder anti-clockwise and remove.

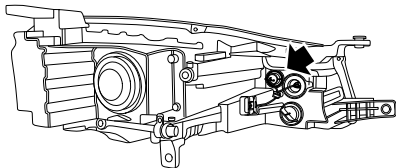

- 9 Close the bonnet—see “Bonnet” in the “Maintenance” section.

- 4 Remove the bulb from the holder.
- 5 Install new bulb into the holder.
- 6 Locate the bulb holder in the lamp, rotate clockwise until fully secured.
- 7 Connect the negative battery terminal.
- 8 Test lamp operation.

### Front Fog Lamp Bulb Renewal

- 1 Disconnect the battery negative terminal.
- 2 Safely raise and support the front of the vehicle with suitable support equipment. DO NOT work under a vehicle that is only supported by a scissor or trolley jack.
- 3 Remove the bottom deflector.
- 4 Rotate the bulb holder anti-clockwise and remove.
- 5 Remove the wiring connector from the bulb holder.
- 6 Refit the wiring connector to the new bulb holder.
- 7 Locate the bulb holder in the lamp, rotate clockwise until fully secured.
- 8 Fit the bottom deflector.
- 9 Connect the negative battery terminal.
- 10 Test lamp operation.

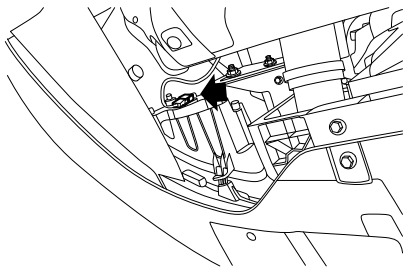

# EMERGENCY INFORMATION

---

## Reverse Lamp Bulb Renewal

- 1 Disconnect the battery negative terminal.
- 2 For reverse lamp bulb replacement, it is necessary to remove the rear bumper cover, seek guidance from an Authorised MG Repairer.
- 3 Rotate the bulb holder anti-clockwise and remove.

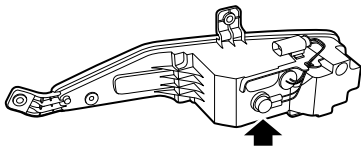

- 4 Remove the bulb from the holder.
- 5 Install new bulb into the holder.
- 6 Locate the bulb holder in the lamp, rotate clockwise until fully secured.
- 7 Fit the rear bumper.
- 8 Connect the negative battery terminal.

- 9 Test lamp operation.



### License Plate Lamp Bulb Renewal

- 1 Open and support the tail gate—see “Alarm Systems” in the “Starting and Driving” section.
- 2 Disconnect the battery negative terminal.
- 3 Remove the tail gate interior trim panel.
- 4 Remove the wiring connector of the lamp.

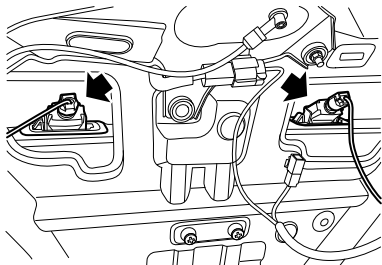

- 5 Rotate the bulb holder anti-clockwise and remove.
- 6 Remove the bulb from the holder.

- 7 Install new bulb into the holder.
- 8 Locate the bulb holder in the lamp, rotate clockwise until fully secured.
- 9 Refit the wiring connector
- 10 Fit the tail gate interior trim panel.
- 11 Connect the negative battery terminal.
- 12 Close the tail gate.
- 13 Test lamp operation.

## EMERGENCY INFORMATION

---

### Front Interior Lamp Bulb Renewal

- 1 Disconnect the battery negative terminal.
- 2 Use a small flat-bladed screwdriver to gently prise the lens from the lamp assembly.

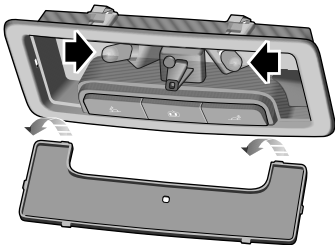

- 3 Remove the bulb from its mounting to remove.
- 4 Install new bulb.
- 5 Install the lens, locate the two prongs at the front of the lens and then carefully flex the lens to locate the two prongs at the rear of the lens into the lamp

assembly. Push the lens upwards until it 'clicks' into position

- 6 Connect the negative battery terminal.
- 7 Test lamp operation.

## **Maintenance**

---

302 *Maintenance*

306 *Bonnet*

308 *Engine Compartment*

309 *Engine*

311 *Cooling System*

313 *Brake*

315 *Battery*

317 *Washer*

319 *Wipers*

322 *Tyres*

328 *Cleaning and Vehicle Care*

# MAINTENANCE

---

## Maintenance

### Routine Servicing

The safety, reliability and performance of your car will depend partly on how well it is maintained. You must ensure that maintenance is carried out when required and according to the information contained in the "Service Schedule".

### Servicing

For next service information, please refer to "Message Centre" in "Instruments and Controls" chapter or information related to entertainment system. After the completion of each service, the next service display will be reset by your MG Authorised Repairer.

**Note: If a service is not carried out (or the display is not reset by the local MG Authorised Repairer after service), the service display cannot provide correct information**

### Service History

Ensure your local MG Authorised Repairer registers the Service History after each service.

### Brake Fluid Replacement

Replace the brake fluid according to the "Service Schedule" requirements.

**Note: Brake fluid replacement will be an additional cost.**

### Coolant Replacement

The engine coolant (anti-freeze and water solution) needs to be replaced according to the "Service Schedule" requirements.

**Note: Coolant replacement will be an additional cost.**

### Emission Control

Your car is fitted with exhaust emission and evaporative control equipment designed to meet specific territorial and legal requirements. Incorrect engine settings may adversely affect exhaust emissions, engine performance

and fuel consumption, as well as causing high temperatures, which could result in damage to the catalytic converter, particulate filter and engine.

## IMPORTANT

You should be aware that unauthorised replacement, modification or tampering with engine settings or this equipment by an owner or motor vehicle repairer could result in the manufacturer's warranty being deemed as invalid.

### Owner Maintenance



***Any significant or sudden drop in fluid levels, or uneven tyre wear, should be reported without delay. For further information, refer to an MG Authorised Repairer.***

In addition to the routine services referred to previously, a number of simple checks must be carried out more frequently. You can perform such checks by yourself. Advice is given as follows.

#### Daily Check

- Operation of lights, horn, direction indicator lamps, wipers, washers and warning lights.
- Operation of seat belts and brakes.
- Look for fluid deposits underneath the car that might indicate a leak.
- Check tyre appearance.

#### Weekly Check

- Engine oil level.
- Coolant level.
- Brake fluid level.
- Windscreen washer fluid level.
- Operate air conditioning.

***Note: The engine oil level should be checked more frequently if the car is driven for prolonged periods at high speeds.***

### Special Driving Conditions

If your car is frequently used in dusty conditions, or operated in extreme climates where sub-zero or very high ambient temperatures are normal, more frequent attention may need to be paid to servicing requirements.

# MAINTENANCE

---

You need to carry out special maintenance operations (refer to Service Portfolio or contact your MG Authorised Repairer).

## Safety in the Garage



***Cooling fans may commence operating after the engine is switched off, and continue operating for a number of minutes. Keep clear of all fans while working in the engine compartment.***

If you need to carry out maintenance, observe the following safety precautions at all times:

- Keep your hands and clothing away from drive belts and pulleys.
- If the car has been driven recently, **DO NOT TOUCH** exhaust and cooling system components until the engine has cooled.
- **DO NOT TOUCH** electrical leads or components while the engine is running, or with the **START/STOP** Switch on.

- **NEVER** leave the engine running in an unventilated area - exhaust gases are poisonous and extremely dangerous.
- **DO NOT** work underneath the car with a wheel changing jack as the only means of support.
- Ensure that sparks and naked lights are far away from the engine compartment.
- Wear protective clothing and work gloves.
- Remove watches and jewelry before working in the engine compartment.
- **DO NOT** allow tools or metal parts of the car to make contact with the battery leads or terminals.

## Toxic Liquid

Fluids used in motor vehicles are poisonous and should not be consumed or brought into contact with open wounds. These include: battery acid, coolant, brake fluid, fuel, engine oil and windscreen washer fluid.

For your own safety, **ALWAYS** read and obey all instructions printed on labels and containers.

### **Used Engine Oil**

Prolonged contact with engine oil may cause serious skin disorders, including dermatitis and cancer of the skin. Wash thoroughly after contact. Used engine oil should be disposed of correctly. Incorrect disposal can cause a threat to the environment.

# MAINTENANCE

## Bonnet

### Opening the Bonnet

 **DO NOT drive when the bonnet is open or retained only by the safety catch.**

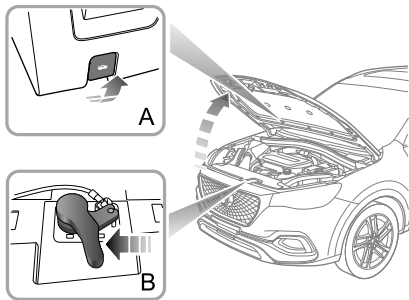

- 1 Pull the bonnet release handle (A) from the inside of the car.
- 2 Push the lever (B) mounted on the bonnet in the arrow direction to release the bonnet safety catch.
- 3 Raise the bonnet to open it.

### Closing the Bonnet

Hold the bonnet using both hands and lower it, allowing it to drop for the last 20 ~ 30 cm to fully close the bonnet.

By attempting to lift the front edge of the bonnet, check if the lock is fully engaged after closing the bonnet. If it is not fully engaged, please reopen the bonnet and repeat the closing action.

### Bonnet Open Alarm

If the bonnet is not fully engaged, when the START STOP switch is in the ON position, the corresponding alarm icon (refer to "Message Centre" in "Instruments and Controls" chapter) will be shown on the message centre display. If it is detected that the bonnet is not fully engaged while driving, an audible warning will sound.



### IMPORTANT

- For safety reasons, the bonnet should be closed well when driving. Therefore you must check after closing the bonnet that the bonnet is securely latched, e.g. the bonnet edge is flush with the body of the car.
- You should stop the car immediately when safety permits and close the bonnet if it is not closed fully when driving.
- Beware of injury to hands while fully closing the bonnet with a downward force.

# MAINTENANCE

---

## Engine Compartment



*While working in the engine compartment, always observe the safety precautions listed under "Safety in the Garage". Refer to "Maintenance" in "Maintenance" section.*

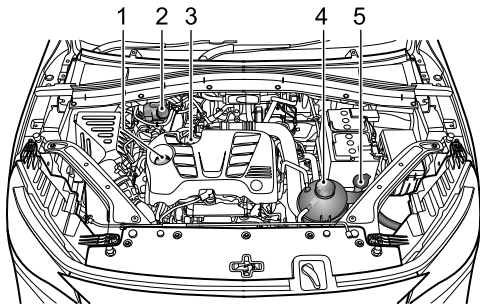

- 1 Engine oil filler cap (black cap)
- 2 Brake fluid reservoir (yellow cap)
- 3 Engine oil dipstick (yellow)
- 4 Coolant reservoir (black cap)
- 5 Washer fluid reservoir (blue cap)

## Engine

### 1.5L Turbocharged Engine Oil

#### ACEA Classification of Engine Oils

European Automobile Manufacturers Association (ACEA) will classify the engine oils based on performance and quality. To ensure the best performance of the vehicle, please only use engine oils that are recommended by the manufacturer (see "Technical Data" - 'Recommended Fluids and Capacities'.

If you are operating the vehicle in extreme temperature conditions please consult your MG Authorised Repairer for advice.

### Engine Oil Level Check and Top Up



*Driving the car with the oil level ABOVE the upper mark, or BELOW the lower mark on the dipstick, will damage the engine. Take care to avoid spilling engine oil onto a hot engine –Spillages may result in a fire!*

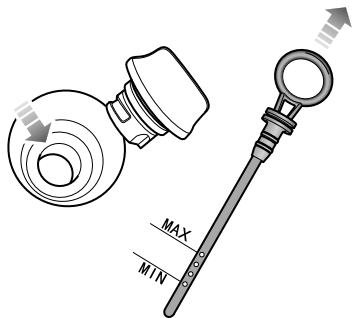

1.5L Turbocharged Engine

# MAINTENANCE

---

Check the oil level weekly and top up with oil when necessary. Ideally, the oil level should be checked with the engine cold and the car resting on level ground. However, if the engine is running and already getting warm, wait for at least five minutes after switching off the START/STOP switch before checking the level.

- 1 Withdraw the dipstick and wipe the blade clean.
- 2 Slowly insert the oil dipstick and pull it out again to check the oil level; the oil level shall not be lower than the 'MIN' mark on the oil dipstick.
- 3 Unscrew the oil filler cap and refill the oil to maintain the oil level between the 'MAX' mark and 'MIN' mark on the oil dipstick.
- 4 Wait for 5 minutes and then recheck the oil level, adding more oil if necessary – DO NOT OVERFILL!
- 5 Finally, ensure the dipstick and filler cap are replaced.

## Engine Oil Specification

Use the engine oil recommended and approved by the manufacturer. Refer to "Recommended Fluids and Capacities" in "Technical Data" chapter.

**Note: DO NOT use any oil additives.**

### IMPORTANT

Check the engine oil more frequently if the car is driven at high speeds for prolonged periods.

## Cooling System

### Coolant Check and Top Up



**DO NOT remove the engine coolant reservoir cap when the cooling system is hot - escaping steam or hot coolant could cause serious injury.**

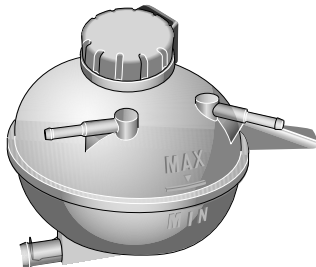

It is recommended that the cooling system should be checked weekly when the cooling system is cold and with the car resting on level ground. If the level is lower than 'MIN' mark, open the expansion tank cap of the cooling system and top up coolant, but the level shall not be higher than 'MAX' mark.

**Note: Prevent coolant coming into contact with the vehicle body when topping up. Coolant will damage paint.**

If the coolant level falls appreciably during a short period, the cooling system leakage may occur, please have it serviced in time by a local MG Authorised Repairer.

### Coolant Specification

Please use the coolant recommended and certified by the manufacturer. Refer to 'Recommended Fluids and Capacities' in "Technical Data" chapter.

**Note: In an emergency, top up the coolant reservoir with a small amount of clean water. However, it should be noted that this will weaken the anti-freeze and anti-corrosion protection and reduce the service life**

## MAINTENANCE

---

*of the coolant. DO NOT refill the cooling system with anti-freeze of different formulations.*

*Note: Refilling of additives inapplicable to this car into coolant may damage the components to be cooled. You are recommended to use the additives certified by the manufacturer, please consult your local Authorised Repairer for details.*

### Antifreeze Fluid



*Coolant is poisonous and can be fatal if swallowed - keep coolant containers sealed and out of the reach of children. If accidental contact of coolant by children is suspected, seek medical assistance immediately.*



*Prevent coolant coming into contact with the skin or eyes. If this occurs, rinse immediately with plenty of water. If eyes are still red, painful or uncomfortable, seek medical attention immediately.*

## Brake

### Brake Pads



**DO NOT rest your foot on the brake pedal while driving; this may overheat the brakes, reduce their efficiency and cause excessive wear.**

For the first 900miles (1500km), you should avoid situations where heavy braking is required.

Remember that regular servicing is vital to ensure that all the brake components are examined for wear at the correct intervals, and replaced when required to ensure long term safety and optimum performance during the interval prescribed in Service Portfolio.

The car needs to run in for 500miles (800km) after the brake pad or disc is replaced.

### Brake Fluid Check and Top Up



**Brake fluid is highly toxic, keep containers sealed and out of the reach of children. If accidental contact of brake fluid is suspected, seek medical attention immediately.**



**Prevent brake fluid coming into contact with the skin or eyes. If this occurs, rinse immediately with plenty of water. If eyes are still red, painful or uncomfortable, seek medical attention immediately.**

The brake fluid level should be checked weekly when the system is cold and with the car on level ground.

The fluid level can be seen through the reservoir and should be maintained between 'MAX' and 'MIN' mark.

**Note: Do not allow the level to drop below the 'MIN' mark or rise above 'MAX' mark.**

# MAINTENANCE

---

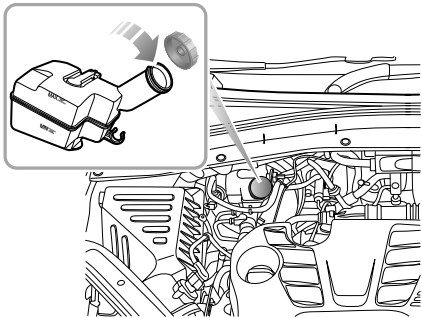

**Note:** Brake fluid will damage painted surfaces. Soak up any spillage with an absorbent cloth immediately and wash the area with a mixture of car shampoo and water.

## Brake Fluid Specification

Use the brake fluid recommended and certified by the manufacturer. Refer to "Recommended Fluids and Capacities" in the "Technical Data" chapter.

### IMPORTANT

Replace brake fluid regularly according to the Service Schedule.



## Battery

### Battery Maintenance



**DO NOT** leave electric components switched on when the engine is not running, the battery may become flat and you will not be able to start the engine.

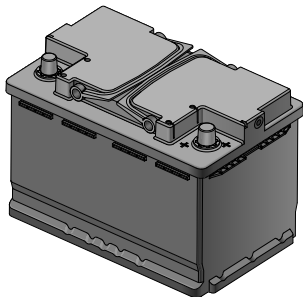

You can see the battery when you open the engine compartment. The battery is maintenance-free type, therefore there is no need to refill fluid.

**Note:** *If the vehicle is stored for more than 1 month, remove the negative terminal from the battery. Make sure that the START/STOP switch has been turned off before connecting or disconnecting the negative terminal. When connecting the negative terminal again, the vehicle must be left in a locked state for 4 hours to re-calibrate the battery condition. Failure to adhere to this will inhibit the stop/start functionality.*

### Battery Replacement



**The battery contains sulphuric acid, which is corrosive.**

The battery contains sulphuric acid, which is corrosive. Please go to a local MG Authorised Repairer to remove and install the battery.

**Note:** *Only fit a replacement battery of the same type and specification as the original to maintain the correct vehicle functionality.*

## MAINTENANCE

---



The battery must be disposed of using an approved method, used batteries can be harmful to the environment. It should be recycled by a professional company. Please consult an MG Authorised Repairer for more details.

## Washer

### Washer Fluid Check and Top Up



*When filling the washer fluid, DO NOT let the washer fluid spill on parts around the engine or on the paint surface of vehicle body. In case the washer fluid is spilled on hands or other parts of the body, please immediately wash with clean water.*

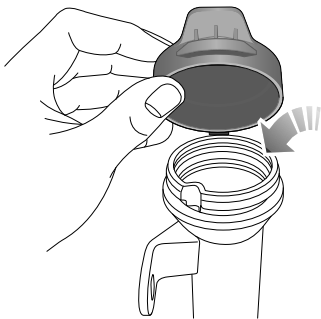

Check the washer fluid level every week. When the level of washer fluid is low, please top up the washer fluid as instructed. Please use the washer fluid recommended and certified by the manufacturer. Refer to 'Recommended Fluids and Capacities' in "Technical Data" chapter.

**Note:** *DO NOT use an anti-freeze or vinegar/water solution in the washer reservoir - anti-freeze will*

# MAINTENANCE

*damage paintwork while vinegar will damage the washer pump.*

## IMPORTANT

- Use the washer fluid recommended and certified by the manufacturer. Misuse of washer fluid in winter may cause damage to the washer motor due to freezing.
- Using the washer switch when there is no washer fluid may cause damage to the washer motor.
- Operating the wipers when the windscreen is dry and there is no washer fluid may cause damage to the windscreen and wipers. Please spray the washer fluid and start the wipers when there is adequate washer fluid.

## Washer Nozzles

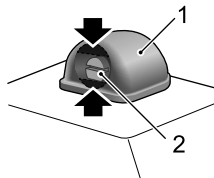

Operate the washers periodically to check that the nozzles are clear and properly directed.

The windscreen washer nozzles are configured during the production. To adjust the windscreen washer nozzle, you can insert a small flat-bladed screwdriver in the upper and bottom gaps (as indicated by the arrow) between the housing (1) and the nozzle (2) and turn downward or upward slightly to adjust to appropriate injection angle.

If the nozzle is obstructed, insert a needle or thin metal wire into the hole to remove the obstruction.

## Wipers

### Wiper Blades

#### IMPORTANT

- Grease, silicon and petroleum products impair the blade's wiping capability. Clean the wiper blades in warm soap water, and check their status periodically.
- Clean the windscreen frequently. **DO NOT** use wipers to remove stubborn or ingrained dirt, it will reduce their effect and their life span.
- If signs of hardness or cracking in the rubber are found, or if the wipers leave streaks or unwiped areas on the screen, then the wiper blades should be replaced.
- Clean the windscreen regularly with an approved glass cleaner and ensure the windscreen is thoroughly cleaned before fitting replacement wiper blades.
- Only fit replacement wiper blades that are identical to the original specification.
- Clean ice and snow from the wipers and ensure they are not frozen or otherwise sticking to the windscreen before attempting to operate them.

# MAINTENANCE

---

## Replacing Front Windscreen Wiper Blades

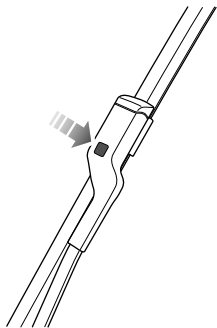

- 1 With the bonnet in closed state, and within 20 seconds of setting the START/STOP Switch to the OFF position, operate the wiper stalk switch by pressing down and release, the wipers will enter the 'service position' and stop on the windscreen.
- 2 Lift the wiper arm away from the windscreen.
- 3 Press the button on the wiper arm (as illustrated), and pull the upper end of the wiper blade outward to disengage from the wiper arm.
- 4 Unhook the blade from the wiper arm and discard.
- 5 Locate the new wiper into the slot of the wiper arm.
- 6 Push the wiper blade towards the arm until the wiper blade is engaged.
- 7 Check whether the wiper blade is fitted correctly to the arm before positioning on the windscreen.
- 8 Operate the wiper stalk switch by pressing down again and release, or set the Start/Stop Switch to ON, the wiper will exit the service mode and automatically return to its original position

## Replacing Rear Window Wiper Blades

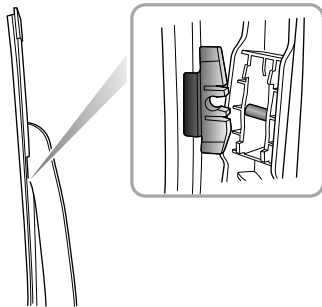

- 1 Lift the wiper arm away from the windscreen.
- 2 Pull the wiper blade connector outward with moderate force to separate it from the wiper arm and discard the wiper blade.
- 3 Put the fitting of the new wiper blade into the slot of the wiper arm. Ensure the wiper blade is properly secured on the wiper arm.
- 4 Place the wiper assembly back on the windscreen.

# MAINTENANCE

---

## Tyres

### Overview

- Take extra care when using new tyres for the first 300miles (500km).
- Avoid excessive cornering at speed.
- Regularly check tyres for damage and foreign objects -remove any foreign objects from the tread.
- Avoid tyre contact with oils, grease and fuel.
- Ensure valve caps are always fitted.
- If the tyre is to be removed always mark the tyre/wheel orientation to ensure correct refitment.

### New Tyres

New tyres may not have the same adhesion properties of the old tyres, please take extra care for 300miles (500km). This action could benefit tyre life.

Tyre or rim damage can happen unnoticed. If abnormal vibrations or handling is experienced, or you think tyre or rim damage has occurred please contact an MG Authorised Repairer.

### Directional Tyres

Directional tyres are marked with 'direction of rotation' (DOR). To maintain handling characteristics, tyre performance, low road noise and extend tyre life, tyres must always be fitted with indication arrow showing the correct 'DOR'.

### Tyre Life

Correct tyre pressures and moderate driving style can extend tyre life. It is recommended to note the followings in service:

- If the vehicle is to be stored for a lengthy time, please move your vehicle at least once in two weeks to 'rotate the tyres'.
- Tyre pressures should be checked monthly when the tyres are cold.
- Avoid cornering at excessive speeds.
- Regularly check tyres for abnormal wear patterns.

The following factors affect the tyre life:



### ***Tyre Pressures***

Incorrect tyre pressures can result in poor driving characteristics and a shortened tyre life. Tyre pressures should be checked at least once a month, and once prior to each long-distance journey.

### ***Driving Style***

Excessively harsh acceleration and braking whilst cornering will reduce tyre life.

### ***Wheel Balance***

The balance of wheels and tyres are well tested before a new vehicle comes out of the factory. But the wheels may be out of balance due to many factors. If wheels are out of balance, shaking or vibration of the steering mechanism may occur and the tyres may start to wear excessively. It is important to rectify this quickly. Each wheel should be rebalanced after installing a new tyre or having a tyre repair.

### ***Wheel Alignment***

Incorrect wheel alignment can cause excessive tyre wear and affect vehicle safety. If the tyres show signs of abnormal

wear, check the wheel alignment and seek advice from an MG Authorised repairer.

# MAINTENANCE

---

## Tyre Check



**DEFECTIVE TYRES ARE DANGEROUS!**  
**DO NOT drive if any tyre is damaged, is excessively worn, or is inflated to an incorrect pressure.**

Always drive with consideration for the condition of the tyres, and regularly inspect the tread and side walls for any sign of distortion (bulges), cuts or wear.

**Note: If possible, protect tyres from contamination by oil, grease and fuel.**

## Tyre Pressures



**Before a long distance journey, the tyre pressure must be checked.**

Check the pressures (including the spare wheel) at least every month, when the tyres are cold.

If it is necessary to check the tyres when they are warm, you should expect the pressures to have increased by 30 ~ 40kPa/0.3 ~ 0.4bar/4.3 ~ 5.8psi. In this circumstance,

NEVER let air out of the tyres in order to match the recommended pressures (cold).

## Valves

Keep the valve caps screwed down firmly - they prevent dirt from entering the valve. Check the valve for leaks (listen for a tell-tale hissing) when you check the tyre pressure.

## Punctured Tyres

Your vehicle is fitted with tyres which may not leak if penetrated by a sharp object, provided the object remains in the tyre. If you are aware of this occurring, reduce speed immediately and drive with caution until the spare wheel can be fitted, or repairs undertaken.

**Note: If the wall of the tyre is damaged or distorted, replace the tyre immediately, do not attempt a repair.**

## Tyre Wear Indicators

Tyres fitted as original equipment have wear indicators moulded into the tread pattern at several points around the circumference. When the tread has worn down to 1.6mm, the indicators will come to the surface of the tread pattern,

producing the effect of a continuous band of rubber across the width of the tyre.

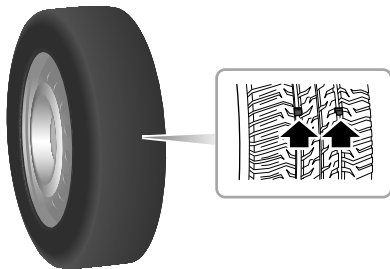

## IMPORTANT

The tyre must be replaced when it is worn to reveal the wear indicator, or there might be the risk of accident.

## Replacement of Tyres



*It is recommended to install the tyres consistent with the original specifications. DO NOT replace the tyres with tyres of any other type. Alternative tyres, of a different specification, may adversely affect the vehicle's driving characteristics and safety. In order to make your driving and safety better guarantee, it is suggested that you consult an MG Authorised Repairer.*

Always have replacement wheels and tyres balanced before use.

## Wheel Fitment Rotation

It is not recommended that you swap wheels from side to side or front to rear in order to equalise tyre wear. Your vehicle is fitted with Tyre Pressure Monitoring System which means that each wheel is programmed to the relative position.

# MAINTENANCE

---

If you do wish to swap wheels and tyres around on the vehicle please consult an MG Authorised Repairer as extra coding will be required.

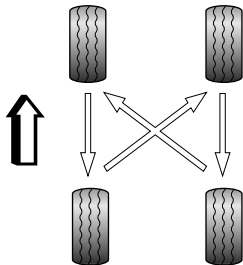

**Note:** Directional tyres (identified from the arrow on the tyre side) **CANNOT** be swapped from side to side.

**Note:** TPMS coding is required after changing wheel positions, please consult a local MG Authorised Repairer for details.

## Tyre/Snow Chains

Unsuitable tyre/snow chains may damage the tyres, wheels, suspension, brakes or bodywork of your car.

Please pay attention to the following requirements in the usage:

- The tyre/snow chains can only be fitted on the drive wheels;
- The thickness of tyre/snow chains shall not exceed 15 mm;
- Please always observe the installation and tension instructions for the tyre/snow chains, as well as the speed limitations of different roads;
- Do not drive faster than 50km/h;
- To avoid the tyre damage and excessive wear of the tyre/snow chains, the tyre/snow chains must be removed while driving on the road without snow.

## Snow Chain Applications

Snow chains cannot be fitted to all wheel/tyre sizes.

Please note: On this vehicle, snow chains can only be fitted to:

Wheel rim size: 6.5J×17

Tyre size: 215/60 R17

**Note:** *If you drive on snowy and icy roads, it is recommended to use winter tyres. Consult an MG Authorised Repairer for details.*

# MAINTENANCE

---

## Cleaning and Vehicle Care



*Abuse of care products may be harmful to health, care products must be safely stored, especially can't let children contact, or it will have the hazard of poisoning.*

## External Care

### Washing Your Car



*You can only clean the vehicle with the START/STOP Switch off, or there might be the risk of accident.*



*For vehicle cleaning in winter, moisture or icing in the braking system will reduce the braking effect, which may have the risk of accident.*



*DO NOT use a high pressure hose to clean the engine compartment – damage to the car's electronic systems may occur.*

In order to preserve the paint finish on your car, please observe the following care points:

- DO NOT use hot water to wash the car.
- DO NOT use detergents or washing up liquid.
- In hot weather, DO NOT wash the car in direct sunlight.
- When using a hose, DO NOT aim the water directly at window, door or sunroof seals, or through wheel apertures onto the brake components.

If the car is particularly dirty, use a hose to flush grime and grit from the bodywork, prior to washing. Then, wash the car using cold or lukewarm water containing a good quality wash and wax shampoo. Always use plenty of water to ensure that grit is flushed from the surface and not ground into the paintwork. After washing, rinse the bodywork with clean water and dry off with a chamois leather.

### *Cleaning the underside*

*Note: DO NOT use a high pressure hose to clean the front compartment – damage to the car's electronic systems may occur.*

From time to time, but particularly during winter months when salt has been used on the roads, use a hose to wash the underside of the car. Flush away accumulations of mud and thoroughly clean those areas where debris can easily collect (wheel arches and panel seams, for example).

## IMPORTANT

- Avoid cleaning the vehicle in direct sunlight.
- When cleaning the vehicle in winter avoid spraying water directly onto door locks and panel gaps due to risk of icing.
- Do not use rough sponges or cloth to clean the car, this will damage the paintwork finish.
- When cleaning the headlamps do not use a dry cloth or sponge, use only warm soapy water.

### **Cleaning with High Pressure Cleaner**

Always read the manufacturers operating instructions.

When using high pressure washers, always ensure there is adequate distance between the spray nozzle and any soft materials, decals or rubber seals.

## IMPORTANT

- Please pay attention to the operating instructions of high pressure cleaner.
- Soft parts on the vehicle should be kept in a large enough distance from the high pressure cleaner.

### **Body Protection**

After washing, examine the paintwork for damage. If the damage has revealed bare metal, use a colored primer first, then apply the correct colour base coat and finish off with a lacquer pencil, if appropriate. Carry out this treatment after washing but before polishing or waxing. More extensive damage to paint or bodywork must be repaired in accordance with the manufacturer's recommendations. Failure to do this will invalidate the Anti-Corrosion Warranty. If in doubt, ask your MG Authorised Repairer.

### **Polishing the Paintwork**



**DO NOT use car polish containing coarse abrasives – these will remove the paint film and damage the gloss finish.**

# MAINTENANCE

---

Polishing is only required when the automotive paint has tarnished and can not return to the bright appearance by waxing.

Occasionally treat the paint surface with an approved polish containing the following properties:

- Very mild abrasives to remove surface contamination without removing or damaging the paint.
- Filling compounds that will fill scratches and reduce their visibility.
- Wax to provide a protective coating between the paint and the elements.

**Note:** *If possible, avoid applying polish or wax products to window glass and rubber seals.*

## Wiper Blades

Wash in warm soapy water. DO NOT use spirit or petrol based cleaners.

## Windows and Mirrors

Regularly clean all windows, inside and out, using an approved glass cleaner.

**Windscreen:** In particular, clean the outside of the screen with glass cleaner after washing the car with wash and wax products, and before fitting new wiper blades.

**Rear screen:** Clean the inside with a soft cloth, using a side to side motion to avoid damaging the heating elements. DO NOT scrape or use abrasive cleaners – this will damage the heating elements.

**Rearview mirrors:** Wash with soapy water. DO NOT use abrasive cleaning compounds or metal scraper.

## Plastic Parts

Plastic parts can be cleaned by the conventional method of cleaning. When the stain is not easy to remove, you can also use a special solvent-free plastic cleaning and curing agent for treatment, and the paint curing agent is not preferable for treatment of plastic parts.

## Paint Damage

Any paint damage or stonechips should be treated with suitable paint/lacquer materials immediately to avoid invalidating the Anti Corrosion Warranty.



## Weather Strips

Any weather strips or rubber aperture seals should be treated with suitable materials (silica gel) if they are cleaned using strong detergents, this should avoid any sticking and maintain the service life of the seal.

## Wheels



***When cleaning the wheels any materials or water that contact the brake disc directly may effect braking efficiency.***

In order to ensure the wheels are kept in optimum condition they should be cleaned regularly.

Only use a recommended non-acidic propriety wheel cleaner. Always read the instructions on the product.

## Cleaning the Interior

### Plastic materials

Clean plastic-faced materials with diluted upholstery cleaner, then wipe with a damp cloth.

***Note: DO NOT polish dashboard components – these should remain non-reflective.***

### Carpet and fabrics

Clean with diluted upholstery cleaner - test a concealed area first.

### Leather

Clean leather trim with warm water and a non-detergent soap. Dry and polish the leather with a dry, clean, lint-free cloth.

***Note: DO NOT use petrol, detergents, furniture creams or polishes as cleaning agents.***

# MAINTENANCE

---

## Instrument Pack, Audio and Navigation Display

Clean with a dry cloth only. DO NOT use cleaning fluids or sprays.

## Airbag Module Covers



**DO NOT allow these areas to be flooded with liquid and DO NOT use petrol, detergent, furniture cream or polishes.**

To protect damage to the airbag SRS, the following areas should be cleaned sparingly with a damp cloth and upholstery cleaner ONLY:

- Steering wheel centre pad.
- Area of dashboard containing the passenger airbag.
- Area of roof lining which encloses the side head impact protection airbags.

## Seat Belts



**DO NOT use bleaches, dyes or cleaning solvents on seat belts.**

Extend the belts, then use warm water and a non-detergent soap to clean. Allow the belts to dry naturally; DO NOT retract them or use the car until they are completely dry.

## **Technical Data**

---

334 *Technical Data Dimensions*

336 *Weights*

340 *Major Parameters of Engine*

341 *Recommended Fluids and  
Capacities*

342 *Four-Wheel Alignment Parameter  
Table (Unladen)*

342 *Wheels and Tyres*

342 *Tyre Pressure (Cold)*

# TECHNICAL DATA

## Technical Data Dimensions

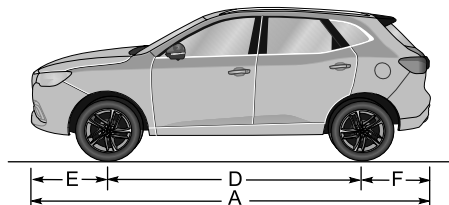
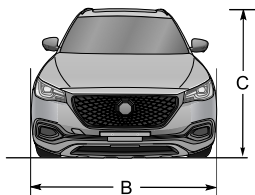

Item, units	Parameter
Overall length A, mm	4574
Overall width B, mm	1876
Overall height C (unladen), mm	1664 ( with body ) 1685 ( including shark fin )
Wheelbase D, mm	2720
Front Overhang E, mm	963

## TECHNICAL DATA

Item, units	Parameter
Rear Overhang F, mm	891
Front wheel track, mm	1574
Rear wheel track, mm	1593
Minimum ground clearance (laden), mm	145
Minimum turning circle diameter, m	11.9
Fuel tank capacity, l	55

**Note:** *Door mirrors and the deformed portion of tyre wall directly above the touchdown point are not included in the total width.*

## TECHNICAL DATA

---

### Weights

Item, units	Parameter				
	I.5T-MT			I.5T-AT	
Person in cab, person	5				
Unladen vehicle weight (kerb), kg	1463	1469	1513	1489	1535
Mass of the optional equipment,kg	26			27	
Gross vehicle weight, kg	2001			2023	
Unladen front axle weight, kg	856	860	886	875	903
Unladen rear axle weight, kg	607	609	627	614	632
Laden front axle weight, kg	987			1009	
Laden rear axle weight, kg	1014			1014	

### Towing Weights

Item, Units	Parameters	
	1.5T-MT	1.5T-AT
Towing limit unbraked, kg	740/745/750	750/750
Towing limit braked, kg	1750	1750
Towing hitch load, kg	75	75

# TECHNICAL DATA

## Towing Bar Dimensions

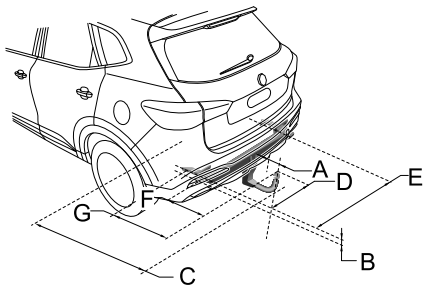

Item	Dimension Description, Units	Parameters
A	Bumper to centre of tow ball, mm	77
B	Attachment point to centre the tow ball, mm	55
C	Wheel centre to centre of tow ball, mm	954
D	Centre of tow ball to side member, mm	500



## TECHNICAL DATA

Item	Dimension Description, Units	Parameters
E	Distance between side members, mm	1000
F	Centre of tow ball to centre of first attachment point, mm	294
G	Centre of tow ball to centre of second attachment point, mm	508

## TECHNICAL DATA

---

### Major Parameters of Engine

Vehicle	Parameter
	1.5T
Bore × Stroke, mm × mm	74×86.6
Capacity, l	1.490
Compression ratio	11.5:1
Fuel type, RON	Unleaded 95 RON to EN228 SPEC

## Recommended Fluids and Capacities

Name	Grade	Capacity	
		6MT	DCT
Engine lubricating oil (after-sales replacement), L	C5 0W-20	4	
Engine coolant, L	Glycol ( OAT )	5.8	
Double Clutch Automatic Transmission fluid, L	DEXRON®DCT Fluid	—	2.45
Manual transmission fluid, L	MTF94	2.2	—
Brake fluid, L	DOT 4	1.0	
Washer fluid, L	ZY-VIII	2.5	
Air conditioning refrigerant, g	R1234yf	560±20	

## TECHNICAL DATA

---

### Four-Wheel Alignment Parameter Table (Unladen)

Item		Parameter
Front	Camber angle	$-14 \pm 45 \phi$
	Castor angle	$4^{\circ}57 \pm 45 \phi$
	Toe-in angle (total toe-in)	$8 \pm 12 \phi$
	King pin inclination	$12^{\circ}45 \pm 45 \phi$
Rear	Camber angle	$-60 \pm 45 \phi$
	Toe-in angle (total toe-in)	$12 \pm 12 \phi$

### Tyre Pressure (Cold)

Wheels	Unladen
Front	250kPa/2.5bar/37psi
Rear	210kPa/2.1bar/31psi

### Wheels and Tyres

Wheel size	7.5J×18	6.5J×17
Tyre size	235/50 R18 97W	215/60 R17 96H

## **Appendix**

---

*344 Removable Tow Bar*

# APPENDIX

---

## Removable Tow Bar

### Tow Bar Operating Instructions

#### Safety:

Operation of the detachable tow bar should only be performed by hand, never use hand tools to operate the locking mechanism.

If the trailer is fitted with a security cable or brake cable it must be attached to the dedicated connection hole in the fixed part of the tow bar.

When a stabiliser coupling is installed on the trailer never use grease on the tow ball.

Always remove the detachable tow ball when not in use if it obscures the registration plate.

#### Preparation:

Remove tow ball cover.

Ensure the tow ball is clean and free from dirt and debris.

Ensure the tow ball is in the 'spring position' (see picture 3.1).

The tow ball is in the spring position if:

- The operating handle is pushed in completely and no colour indication is shown inside the indication area of the operating handle.
- The slider is pulled fully towards the tow ball (shown in picture 3.1).
- It is not possible to lock the system with the supplied locking keys (see picture 5.2).

The tow ball is NOT in the spring position if:

- The operating handle is popped out and shows a red field in the indication area of the operating handle (see picture 3.1)
- The slider is pushed out towards the tow ball (the part is indicated by in picture 3.1).
- It is possible to lock the system with the supplied keys (see picture 5.2).

To place the tow ball in the spring position:

- Unlock the tow ball (see picture 6.1)
- Push the operating handle inwards, rotate in a clockwise direction (whilst pushing inwards) until the handle remains in position (see picture 3.2). If unsure repeat operation.



## APPENDIX

---

- Check the tow ball for security – no play should be evident.

The tow ball is now ready for use.

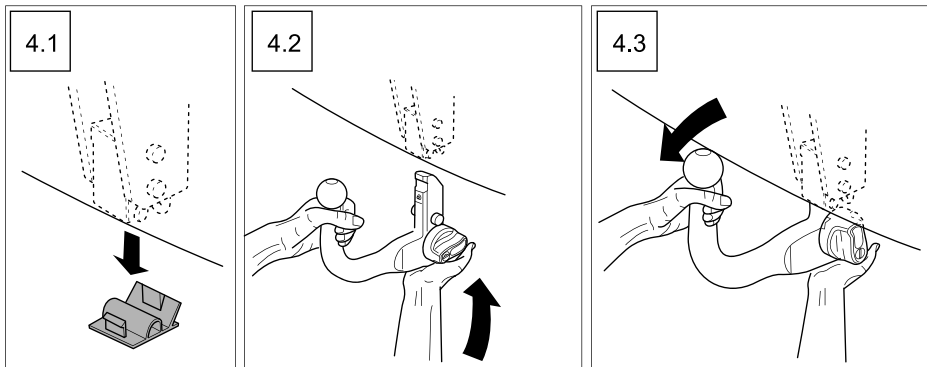



### Care Points

- Always check the tow ball for correct mounting every time prior to use.
- Never attempt to attach/detach a tow ball whilst trailer/accessory attached.
- Always keep the tow ball clean and free from debris, do not clean with high pressure washer.
- Never use a tow ball that has signs of damage, excessive wear or modification.
- Never use a tow ball that has been installed by any other method than 'hand pressure'.

### Removal

Always disconnect the trailer/accessory and safety cable prior to tow ball removal.

- Unlock the detachable tow ball by turning the locking key clockwise using your thumb and forefinger (see picture 6.1).
- Hold the tow ball with your left hand, push the operating handle fully inwards and turn clockwise until the operating handle remains in position (see picture 6.3).

- The tow ball can now be removed from the housing in a downward motion (see picture 6.4). **WARNING**, this item is heavy, do not allow it to drop.
- Refit the plastic cover into the housing (see picture 6.5).

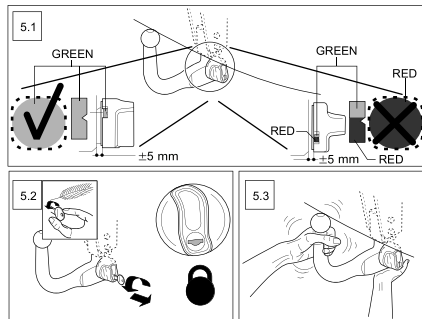

# APPENDIX

---

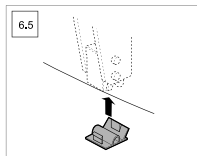
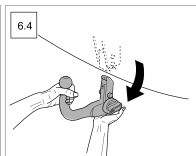
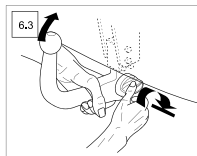
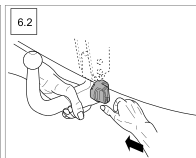
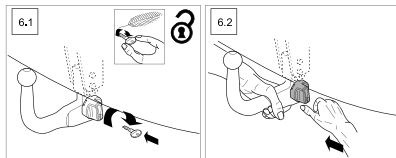

# ADDENDUM – AIR CONDITIONING AND AUDIO SYSTEMS

---

## Restricted Operation During Apple CarPlay and Android Auto Telephone Calls

Whilst the Infotainment System is connected to a mobile telephone via Apple CarPlay or Android Auto, certain telephone functions may restrict the display change function.

During a telephone call using Apple CarPlay or Android Auto the Infotainment System screen displays details of the call and caller/contact. This screen cannot be changed or exited during the call and therefore restricts access to other functions that are available via the Infotainment System screen.

### *Air Conditioning and Heater (HVAC) Function Restrictions*

During an Apple CarPlay or Android Auto telephone call it is not possible to access the HVAC adjustment function within the Infotainment System. This means that blower speed and temperature settings cannot be accessed or adjusted.

To switch the AC blower on or off during a telephone conversation whilst using Apple CarPlay or Android Auto please hold the AC Control Shortcut key in the Control Panel for 3 seconds, the blower will switch on or off depending on the current working state.

Note: When switching the blower back on, the speed settings will revert to the settings prior to switching off.

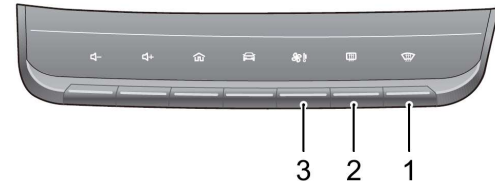

- 1 Defrost/Demist Button
- 2 Heated Rear Window Button
- 3 A/C Control Shortcut